

Minimizing FN-1501-related cytotoxicity in normal cells

Author: BenchChem Technical Support Team. **Date:** April 2026

Compound of Interest

Compound Name: FN-1501
CAS No.: 1429515-59-2
Cat. No.: B607522

[Get Quote](#)

Technical Support Center: FN-1501

Welcome to the technical support center for **FN-1501**. This resource is designed to assist researchers, scientists, and drug development professionals in effectively utilizing **FN-1501** while minimizing potential cytotoxicity in normal cells during in vitro experimentation.

Frequently Asked Questions (FAQs)

Q1: What is **FN-1501** and what is its mechanism of action?

A1: **FN-1501** is a potent, small molecule multi-kinase inhibitor.^{[1][2][3]} Its primary targets are FMS-like tyrosine kinase 3 (FLT3) and cyclin-dependent kinases (CDK) 2, 4, and 6.^{[1][4]} By inhibiting these kinases, **FN-1501** can disrupt cell cycle regulation and induce apoptosis, thereby inhibiting the proliferation of tumor cells that overexpress these particular kinases.^{[1][2]} FLT3 is a receptor tyrosine kinase crucial for the growth and differentiation of hematopoietic precursor cells and is frequently mutated in acute myeloid leukemia (AML).^[5] CDKs are essential for regulating cell cycle progression.^[2] **FN-1501** also shows inhibitory activity against other kinases such as KIT, PDGFR, VEGFR2, ALK, and RET.^{[5][6]}

Q2: What is the known cytotoxic profile of **FN-1501** in normal cells?

A2: Pre-clinical data indicates that **FN-1501** exhibits potent antitumor activity with little cytotoxicity observed in normal lymphocyte cells.[4] In a Phase I/II clinical trial involving patients with advanced solid tumors, the most common treatment-related adverse events were generally mild and reversible, including fatigue, nausea, and diarrhea.[6] Dose-limiting toxicities were observed at the highest tested dose of 226 mg and included Grade 3 thrombocytopenia and a Grade 3 infusion-related reaction.[5][6] While this suggests a manageable safety profile in vivo, it is crucial for researchers to empirically determine the cytotoxic threshold in their specific in vitro models of normal cells, as sensitivities can vary between cell types.

Q3: Which signaling pathways are affected by **FN-1501**?

A3: As an inhibitor of FLT3, **FN-1501** can modulate several downstream signaling cascades that control cellular proliferation, growth, and survival.[5] The primary pathways affected by the inhibition of FLT3 include the RAS/RAF/MAPK, PI3K/AKT/mTOR, and JAK/STAT pathways.[5] By inhibiting CDKs, **FN-1501** directly interferes with the machinery that governs cell cycle progression from one phase to the next.

Signaling Pathway Modulated by FN-1501

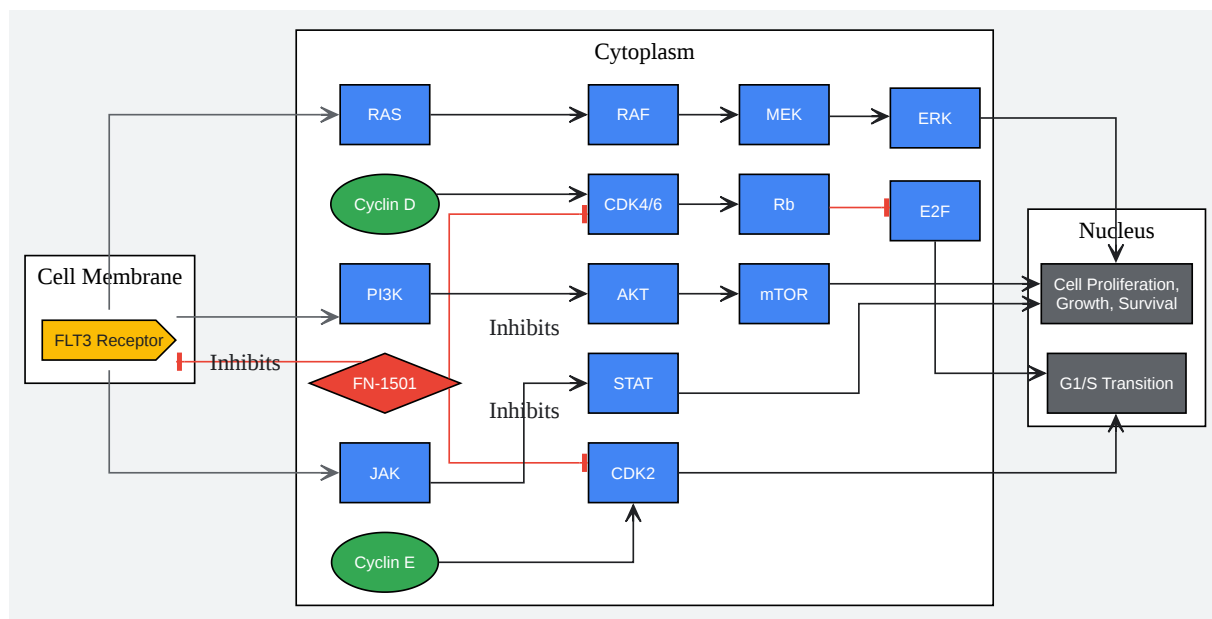

[Click to download full resolution via product page](#)

Caption: **FN-1501** inhibits FLT3 and CDKs, blocking key pro-survival and cell cycle pathways.

Troubleshooting Guides

This section provides guidance for specific issues that may arise during your experiments with **FN-1501**.

Issue 1: High Cytotoxicity Observed in Normal/Control Cell Lines

If you are observing significant cell death in your non-cancerous control cell lines, it may be due to on-target effects on essential cellular processes (like cell division) or potential off-target effects.

Troubleshooting Workflow

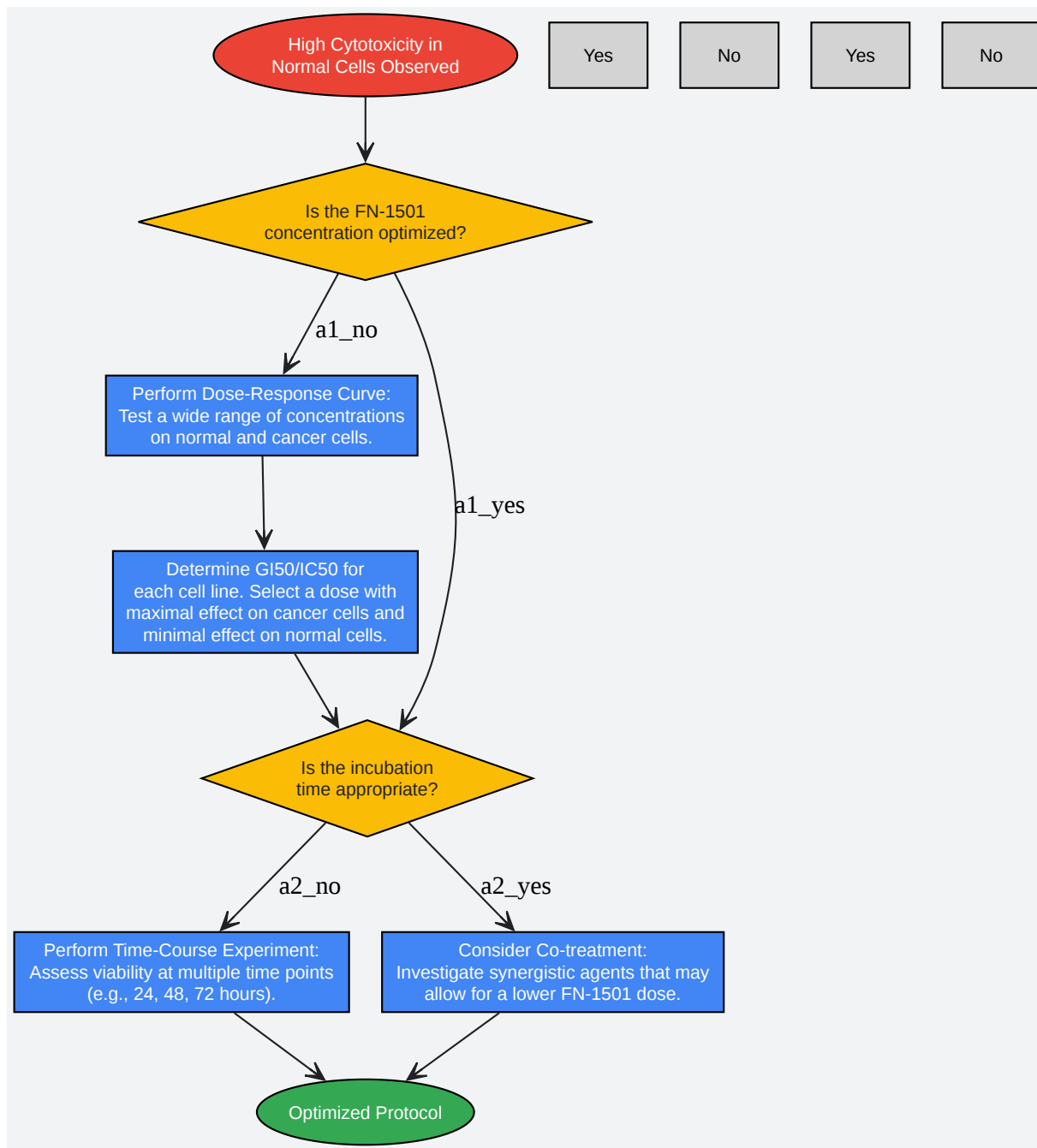

[Click to download full resolution via product page](#)

Caption: A logical workflow for troubleshooting **FN-1501**-related cytotoxicity in normal cells.

Quantitative Data Summary

The following tables summarize the known inhibitory concentrations of **FN-1501** against its primary kinase targets and its growth-inhibitory concentrations against various human cancer cell lines. This data is critical for designing experiments with appropriate concentration ranges. Note the high potency against its intended targets.

Table 1: **FN-1501** Inhibitory Activity against Kinase Targets

Target	IC50 (nM)
FLT3	0.28 ± 0.01
CDK2/cyclin A	2.47 ± 0.21
CDK4/cyclin D1	0.85 ± 0.28
CDK6/cyclin D1	1.96 ± 0.08

Data sourced from MedChemExpress.[\[4\]](#)

Table 2: **FN-1501** Growth Inhibition (GI50) in Human Cancer Cell Lines

Cell Line	Cancer Type	GI50 (nM)
RS4;11	Acute Leukemia	0.05 ± 0.01
HCT-116	Colon Cancer	0.09 ± 0.04
NCI-H82	Lung Cancer	0.11 ± 0.02
MGC803	Gastric Cancer	0.37 ± 0.04
MCF-7	Breast Cancer	2.84 ± 0.25

Data sourced from MedChemExpress.[\[4\]](#)

Recommendation: Based on the data, **FN-1501** is potent in the low nanomolar range against cancer cells. When working with normal cells, it is advisable to start with a concentration range that brackets the GI50 values of sensitive cancer cell lines and extend lower. For example, a

starting range of 0.1 nM to 100 nM would be appropriate for an initial dose-response experiment.

Experimental Protocols

Protocol 1: Determining the Cytotoxic Profile of **FN-1501** using an MTT Assay

This protocol provides a standard method for assessing cell viability and determining the GI50 (concentration that inhibits cell growth by 50%) of **FN-1501** in both normal and cancer cell lines.

Objective: To quantify the dose-dependent cytotoxic effect of **FN-1501**.

Materials:

- Cell lines of interest (e.g., a normal fibroblast line like MRC-5 and a cancer cell line like HCT-116)
- Complete culture medium
- **FN-1501** stock solution (e.g., 10 mM in DMSO)
- 96-well cell culture plates
- MTT (3-(4,5-dimethylthiazol-2-yl)-2,5-diphenyltetrazolium bromide) solution (5 mg/mL in PBS)
- Solubilization buffer (e.g., DMSO or a solution of 10% SDS in 0.01 M HCl)
- Multichannel pipette
- Plate reader (absorbance at 570 nm)

Methodology:

- Cell Seeding:
 - Trypsinize and count cells.

- Seed cells into a 96-well plate at a predetermined optimal density (e.g., 2,000-5,000 cells/well in 100 μ L of medium).
- Incubate overnight at 37°C, 5% CO₂ to allow for cell attachment.
- Compound Treatment:
 - Prepare serial dilutions of **FN-1501** in complete medium. A typical final concentration range could be 0.01 nM to 1 μ M.
 - Include a "vehicle control" (medium with the same percentage of DMSO as the highest **FN-1501** concentration) and a "no-cell" blank control.
 - Carefully remove the old medium from the wells and add 100 μ L of the medium containing the respective **FN-1501** dilutions (or vehicle control).
 - Incubate for the desired period (e.g., 72 hours).
- MTT Assay:
 - After incubation, add 20 μ L of MTT solution (5 mg/mL) to each well.
 - Incubate for 3-4 hours at 37°C until purple formazan crystals are visible.
 - Carefully aspirate the medium from each well.
 - Add 150 μ L of solubilization buffer (e.g., DMSO) to each well to dissolve the formazan crystals.
 - Gently shake the plate for 15 minutes to ensure complete dissolution.
- Data Acquisition and Analysis:
 - Measure the absorbance at 570 nm using a plate reader.
 - Subtract the average absorbance of the "no-cell" blank from all other values.
 - Calculate the percentage of cell viability for each concentration relative to the vehicle control: $(\text{Absorbance}_{\text{treated}} / \text{Absorbance}_{\text{vehicle}}) * 100$.

- Plot the percentage of viability against the log of the **FN-1501** concentration and use a non-linear regression analysis to determine the GI50 value.

Protocol 2: Strategy to Mitigate Cytotoxicity - Reducing Serum Concentration

Some compounds exhibit higher cytotoxicity in low-serum conditions. Conversely, for normal, non-proliferating cells, reducing serum might decrease their susceptibility to cell-cycle-dependent drugs like **FN-1501**. This protocol tests that hypothesis.

Objective: To assess if reducing serum concentration in the culture medium can minimize **FN-1501**'s toxicity in normal cells.

Materials:

- Same as Protocol 1, plus low-serum medium (e.g., 1% or 0.5% FBS).

Methodology:

- Cell Seeding:
 - Seed normal cells (e.g., primary human dermal fibroblasts) in two separate 96-well plates as described in Protocol 1.
- Serum Starvation (for one plate):
 - After overnight attachment, replace the medium in one plate with low-serum medium. Keep the other plate in complete (e.g., 10% FBS) medium.
 - Incubate the low-serum plate for 24 hours to induce quiescence.
- Compound Treatment:
 - Prepare serial dilutions of **FN-1501** in both complete medium and low-serum medium.
 - Treat the corresponding plates with the respective media containing **FN-1501** dilutions.
 - Incubate both plates for the desired duration (e.g., 48-72 hours).

- MTT Assay and Analysis:
 - Perform the MTT assay on both plates as described in Protocol 1.
 - Calculate and compare the GI50 values for **FN-1501** in normal cells under high-serum and low-serum conditions. A higher GI50 in low-serum conditions would indicate that quiescent cells are less sensitive, providing a potential strategy for selective targeting of proliferating cancer cells.

Need Custom Synthesis?

BenchChem offers custom synthesis for rare earth carbides and specific isotopic labeling.

Email: info@benchchem.com or [Request Quote Online](#).

References

- [1. Fn-1501 | C22H25N9O | CID 72195175 - PubChem \[pubchem.ncbi.nlm.nih.gov\]](#)
- [2. Facebook \[cancer.gov\]](#)
- [3. fn-1501 - My Cancer Genome \[mycancergenome.org\]](#)
- [4. medchemexpress.com \[medchemexpress.com\]](#)
- [5. A Multicenter, Open-Label, Phase I/II Study of FN-1501 in Patients with Advanced Solid Tumors - PMC \[pmc.ncbi.nlm.nih.gov\]](#)
- [6. ascopubs.org \[ascopubs.org\]](#)
- To cite this document: BenchChem. [Minimizing FN-1501-related cytotoxicity in normal cells]. BenchChem, [2026]. [Online PDF]. Available at: [\[https://www.benchchem.com/product/b607522/docs#minimizing-fn-1501-related-cytotoxicity-in-normal-cells\]](https://www.benchchem.com/product/b607522/docs#minimizing-fn-1501-related-cytotoxicity-in-normal-cells)

Disclaimer & Data Validity:

The information provided in this document is for Research Use Only (RUO) and is strictly not intended for diagnostic or therapeutic procedures. While BenchChem strives to provide accurate protocols, we make no warranties, express or implied, regarding the fitness of this product for every specific experimental setup.

Technical Support: The protocols provided are for reference purposes. Unsure if this reagent suits your experiment?

Need Industrial/Bulk Grade? [Request Custom Synthesis Quote](#)

BenchChem

Our mission is to be the trusted global source of essential and advanced chemicals, empowering scientists and researchers to drive progress in science and industry.

Contact

Address: 3281 E Guasti Rd

Ontario, CA 91761, United States

Phone: (601) 213-4426

Email: info@benchchem.com

[Contact our Ph.D. Support Team for a compatibility check](#)