

H3B-6527: A Comparative Analysis of Kinase Cross-Reactivity

Author: BenchChem Technical Support Team. **Date:** April 2026

Compound of Interest

Compound Name: H3B-6527
CAS No.: 1702259-66-2
Cat. No.: B607911

[Get Quote](#)

For Researchers, Scientists, and Drug Development Professionals: An objective comparison of the kinase selectivity profile of **H3B-6527** against other selective FGFR4 inhibitors, supported by experimental data and detailed methodologies.

H3B-6527 is a covalent, irreversible inhibitor of Fibroblast Growth Factor Receptor 4 (FGFR4), a receptor tyrosine kinase implicated in the progression of certain cancers, particularly hepatocellular carcinoma (HCC) driven by the FGF19-FGFR4 signaling axis.[1][2][3] The clinical efficacy of targeted kinase inhibitors is intrinsically linked to their selectivity. Off-target kinase inhibition can lead to undesirable toxicities and diminish the therapeutic window. This guide provides a comparative analysis of the cross-reactivity of **H3B-6527** with other kinases, presenting its performance alongside other selective FGFR4 inhibitors, roblitinib (FGF401) and fisogatinib (BLU-554).

Comparative Kinase Inhibition Profile

The selectivity of **H3B-6527** and its alternatives has been quantified through in vitro kinase inhibition assays. The half-maximal inhibitory concentration (IC50) values, which represent the

concentration of an inhibitor required to reduce the activity of a kinase by 50%, are summarized in the table below. Lower IC50 values indicate greater potency.

Kinase Target	H3B-6527 IC50 (nM)	Roblitinib (FGF401) IC50 (nM)	Fisogatinib (BLU-554) IC50 (nM)
FGFR4	<1.2[1]	1.9[1][4]	5[2]
FGFR1	320[1]	>10,000[1]	624[2]
FGFR2	1,290[1]	>10,000[1]	2,203[2]
FGFR3	1,060[1]	>10,000[1]	624[2]
TAOK2	690[1]	Not Reported	Not Reported
JNK2	>10,000[1]	Not Reported	Not Reported
CSF1R	>10,000[1]	Not Reported	Not Reported

Data compiled from publicly available sources.[1][2][4]

As the data indicates, **H3B-6527** is a highly potent inhibitor of FGFR4 with an IC50 value of less than 1.2 nM.[1] It demonstrates significant selectivity for FGFR4 over other members of the FGFR family, with at least a 250-fold higher concentration required to inhibit FGFR1, FGFR2, and FGFR3 to the same extent.[1] Roblitinib (FGF401) also shows exceptional selectivity for FGFR4, with no significant activity observed against FGFR1, FGFR2, or FGFR3 at concentrations up to 10,000 nM.[1] Fisogatinib (BLU-554) is another potent FGFR4 inhibitor, though its selectivity margin over other FGFR isoforms is less pronounced compared to **H3B-6527** and roblitinib.[2]

Signaling Pathway and Experimental Workflow

To provide a comprehensive understanding of the context in which **H3B-6527** functions, the following diagrams illustrate the FGFR4 signaling pathway and a typical experimental workflow for determining kinase selectivity.

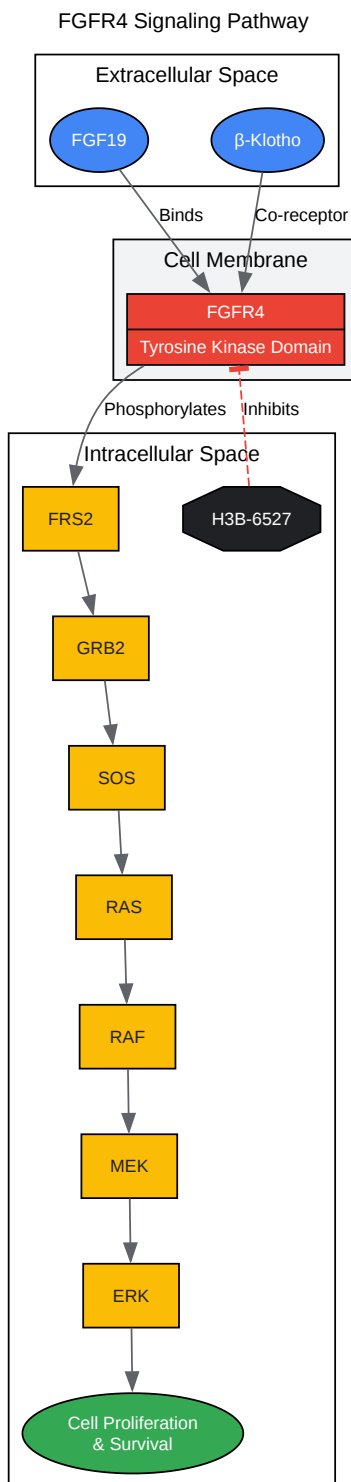

[Click to download full resolution via product page](#)

Caption: The FGFR4 signaling cascade is activated by FGF19 and the co-receptor β -Klotho, leading to downstream activation of the MAPK/ERK pathway and promoting cell proliferation and survival. **H3B-6527** selectively inhibits the kinase activity of FGFR4.

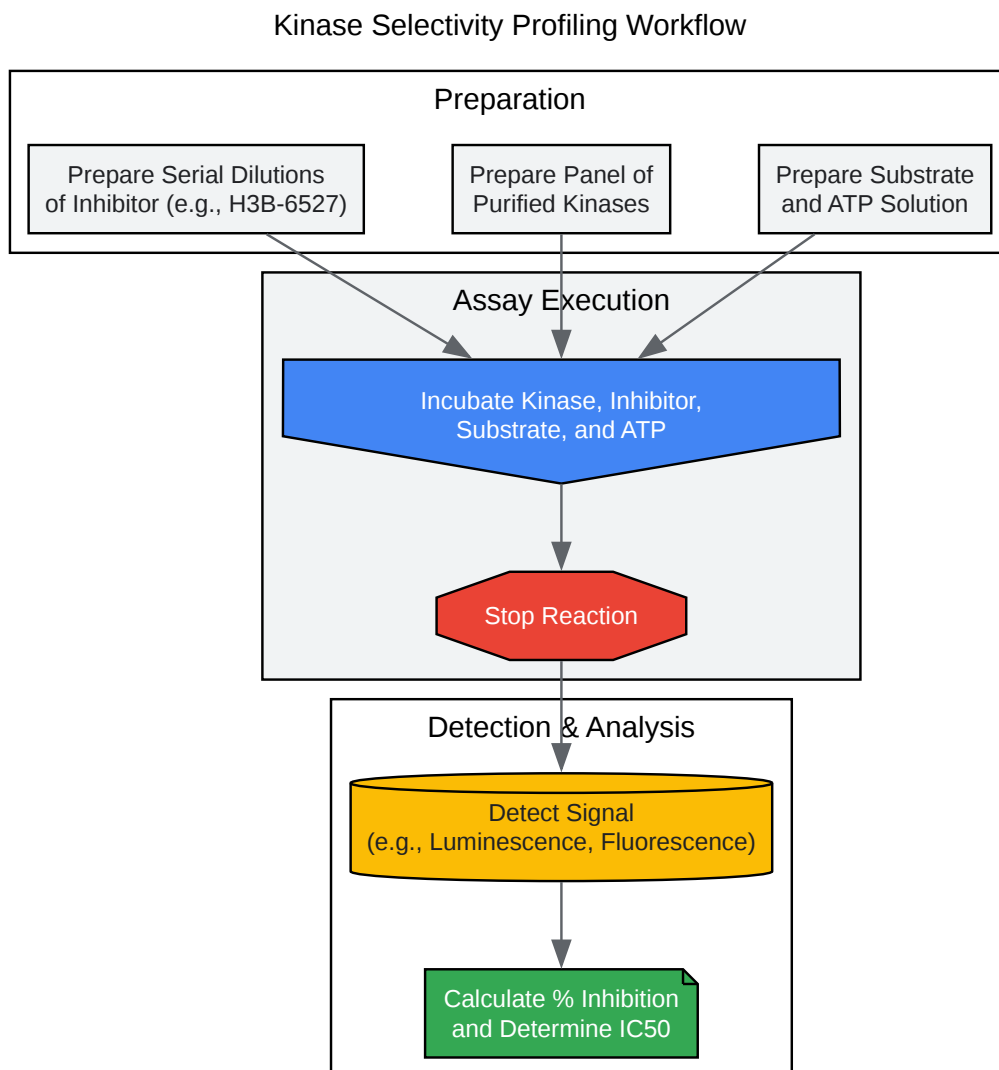

[Click to download full resolution via product page](#)

Caption: A generalized workflow for in vitro kinase selectivity profiling, from reagent preparation to data analysis, to determine the IC50 values of an inhibitor against a panel of kinases.

Experimental Protocols

The determination of kinase inhibitor selectivity is crucial for preclinical drug development. Below is a detailed methodology representative of the experiments used to generate the comparative data in this guide.

Objective: To determine the half-maximal inhibitory concentration (IC50) of a test compound (e.g., **H3B-6527**) against a panel of purified protein kinases.

Materials:

- Test compound (**H3B-6527**)
- Purified recombinant kinases (FGFR1, FGFR2, FGFR3, FGFR4, etc.)
- Kinase-specific peptide substrates
- Adenosine triphosphate (ATP)
- Kinase reaction buffer (e.g., containing Tris-HCl, MgCl₂, DTT)
- Detection reagent (e.g., ADP-Glo™ Kinase Assay kit)
- Microplates (e.g., 384-well format)
- Multichannel pipettes and a plate reader (luminometer or fluorometer)

Procedure:

- **Compound Preparation:** A stock solution of the test compound is prepared in a suitable solvent, such as dimethyl sulfoxide (DMSO). A series of dilutions are then prepared to cover a wide range of concentrations (e.g., from 1 nM to 10,000 nM).
- **Kinase Reaction Setup:**

- The kinase reactions are set up in a multi-well plate.
- To each well, the kinase reaction buffer, the specific purified kinase, and the corresponding peptide substrate are added.
- The test compound at various concentrations is then added to the wells. Control wells containing only the solvent (DMSO) are included to determine the 100% kinase activity level.
- Reaction Initiation and Incubation:
 - The kinase reaction is initiated by the addition of ATP. The concentration of ATP is typically kept near its Michaelis-Menten constant (K_m) for each specific kinase to ensure accurate IC_{50} determination.
 - The plate is incubated at a controlled temperature (e.g., room temperature or 30°C) for a specified period (e.g., 60 minutes) to allow the enzymatic reaction to proceed.
- Reaction Termination and Signal Detection:
 - Following incubation, the reaction is stopped.
 - A detection reagent is added to quantify the extent of the kinase reaction. For instance, in the ADP-Glo™ assay, the amount of ADP produced, which is directly proportional to kinase activity, is measured via a luminescent signal.
- Data Analysis:
 - The luminescent or fluorescent signal from each well is measured using a plate reader.
 - The percentage of kinase inhibition for each compound concentration is calculated relative to the control wells.
 - The IC_{50} value is determined by fitting the concentration-response data to a sigmoidal dose-response curve using appropriate software (e.g., GraphPad Prism).

This rigorous and systematic approach ensures the generation of reliable and reproducible data, which is essential for comparing the selectivity profiles of different kinase inhibitors and

guiding the development of safer and more effective targeted therapies.

Need Custom Synthesis?

BenchChem offers custom synthesis for rare earth carbides and specific isotopic labeling.

Email: info@benchchem.com or [Request Quote Online](#).

References

- [1. medchemexpress.com](https://www.medchemexpress.com) [[medchemexpress.com](https://www.medchemexpress.com)]
- [2. selleckchem.com](https://www.selleckchem.com) [[selleckchem.com](https://www.selleckchem.com)]
- [3. Phase 1 dose escalation study of FGFR4 inhibitor in combination with pembrolizumab in advanced solid tumors patients - PMC](#) [[pmc.ncbi.nlm.nih.gov](https://pubmed.ncbi.nlm.nih.gov/)]
- [4. selleckchem.com](https://www.selleckchem.com) [[selleckchem.com](https://www.selleckchem.com)]
- To cite this document: BenchChem. [H3B-6527: A Comparative Analysis of Kinase Cross-Reactivity]. BenchChem, [2026]. [Online PDF]. Available at: [<https://www.benchchem.com/product/b607911/docs#h3b-6527-a-comparative-analysis-of-kinase-cross-reactivity>]

Disclaimer & Data Validity:

The information provided in this document is for Research Use Only (RUO) and is strictly not intended for diagnostic or therapeutic procedures. While BenchChem strives to provide accurate protocols, we make no warranties, express or implied, regarding the fitness of this product for every specific experimental setup.

Technical Support: The protocols provided are for reference purposes. Unsure if this reagent suits your experiment?

Need Industrial/Bulk Grade? [Request Custom Synthesis Quote](#)

BenchChem

Our mission is to be the trusted global source of essential and advanced chemicals, empowering scientists and researchers to drive progress in science and industry.

Contact

Address: 3281 E Guasti Rd

Ontario, CA 91761, United States

Phone: (601) 213-4426

Email: info@benchchem.com

[Contact our Ph.D. Support Team for a compatibility check](#)