

Cenobamate: A Novel Dual-Mechanism Approach for Temporal Lobe Epilepsy

Author: BenchChem Technical Support Team. **Date:** April 2026

Compound of Interest

Compound Name: GABAA receptor modulator-1

Cat. No.: B607588

[Get Quote](#)

An In-depth Technical Guide for Researchers and Drug Development Professionals

Executive Summary

Temporal lobe epilepsy (TLE) is the most common form of focal epilepsy in adults, and a significant portion of patients are refractory to current anti-seizure medications (ASMs). Cenobamate, a novel ASM, has demonstrated significant efficacy in reducing seizure frequency in patients with uncontrolled focal seizures, including those associated with TLE. This technical guide provides a comprehensive overview of Cenobamate, focusing on its unique dual mechanism of action, preclinical and clinical data, and detailed experimental protocols. The information presented is intended to support researchers, scientists, and drug development professionals in understanding the therapeutic potential of Cenobamate for TLE.

Mechanism of Action

Cenobamate exerts its anti-seizure effects through a distinct dual mechanism of action, targeting both excitatory and inhibitory neurotransmission.[1]

- **Modulation of Voltage-Gated Sodium Channels:** Cenobamate preferentially inhibits the persistent sodium current (INaP) over the transient sodium current (INaT).[1] The persistent

sodium current is implicated in the generation of pathological sustained neuronal depolarization and seizure activity. By selectively inhibiting INaP, Cenobamate reduces neuronal hyperexcitability without significantly affecting the normal physiological functions associated with the transient sodium current.[1]

- Positive Allosteric Modulation of GABAA Receptors: Cenobamate enhances inhibitory neurotransmission by acting as a positive allosteric modulator of γ -aminobutyric acid (GABA) type A receptors at a non-benzodiazepine binding site.[1] This action potentiates GABA-mediated chloride currents, leading to hyperpolarization of the neuronal membrane and a reduction in neuronal firing.[1]

This dual action of reducing neuronal excitation and enhancing inhibition is believed to contribute to the high rates of seizure reduction and freedom observed in clinical trials.[1]

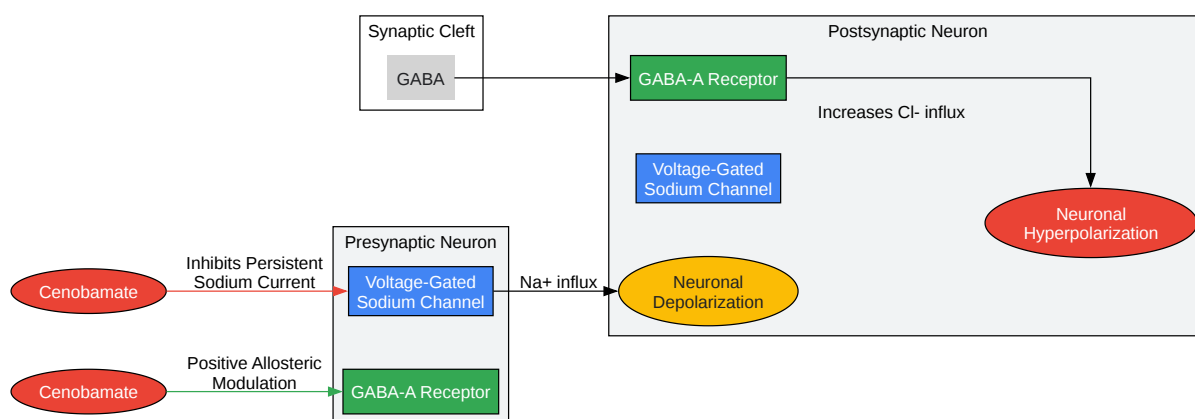

[Click to download full resolution via product page](#)

Caption: Dual mechanism of action of Cenobamate.

Preclinical Evaluation

Cenobamate has demonstrated broad-spectrum anticonvulsant activity in a variety of well-established animal models of epilepsy.[2][3]

Experimental Protocols

2.1.1. Maximal Electroshock (MES) Test

The MES test is a model of generalized tonic-clonic seizures and is used to identify compounds that prevent seizure spread.

- Animals: Male ICR mice (23 ± 3 g).[4]
- Procedure: A test substance is administered orally. After a specified time, a maximal electroshock (e.g., 60 Hz sine wave, 50 mA, 200 msec duration) is applied through corneal electrodes.[4]
- Endpoint: The absence of a tonic hindlimb extension seizure is considered a protective effect.[4]

2.1.2. Pentylenetetrazol (PTZ) Seizure Test

The PTZ test is a model for myoclonic and absence seizures and identifies compounds that raise the seizure threshold.

- Animals: Male CF-1 mice or Sprague Dawley rats.[5]
- Procedure: Following administration of the test compound, a subcutaneous injection of PTZ (e.g., 85 mg/kg in mice) is given.[5]
- Endpoint: The absence of clonic spasms of the forelimbs, hindlimbs, or jaw for a defined period (e.g., 3-5 seconds) is considered protective.[5]

2.1.3. 6 Hz Psychomotor Seizure Test

The 6 Hz test is a model of therapy-resistant partial seizures.

- Animals: Male ICR-CD1 mice.[6]
- Procedure: After administration of the test compound, a low-frequency (6 Hz), long-duration (3 seconds) electrical stimulus (e.g., 22, 32, or 44 mA) is delivered via corneal electrodes.[7]
- Endpoint: Protection is defined as the absence of seizure activity, characterized by immobility, forelimb clonus, and other stereotyped behaviors.[8]

2.1.4. Amygdala Kindling Model

The kindling model mimics the progressive development of epilepsy (epileptogenesis).

- Animals: Male rats.[9]
- Procedure: Electrodes are surgically implanted into the amygdala. A sub-threshold electrical stimulus is applied daily, leading to a gradual increase in seizure severity and duration.[9]
- Endpoint: The ability of a compound to suppress the fully kindled seizures or to retard the development of kindling is assessed.[10]

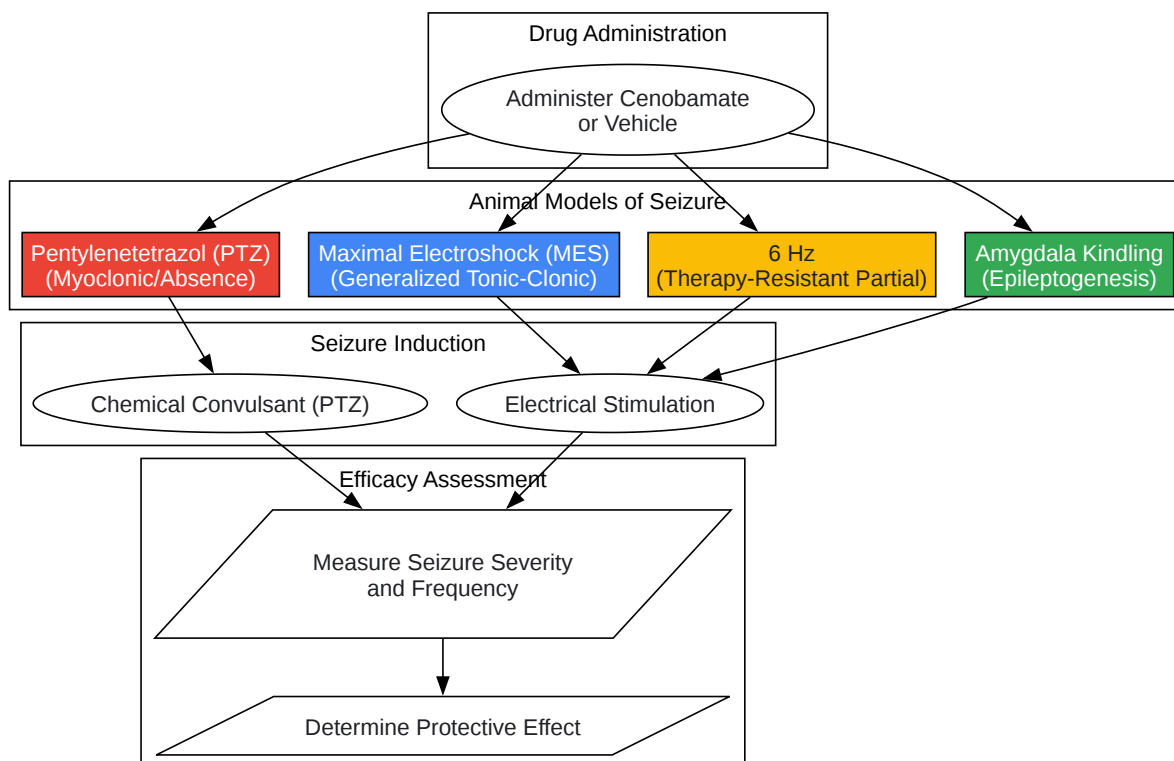

[Click to download full resolution via product page](#)

Caption: Preclinical evaluation workflow for Cenobamate.

Clinical Efficacy

The clinical development program for Cenobamate has consistently demonstrated its efficacy and safety as an adjunctive therapy for adults with uncontrolled focal seizures.

Key Clinical Trials

Two pivotal Phase 2, multicenter, double-blind, randomized, placebo-controlled trials have been central to establishing the efficacy of Cenobamate:

- Study C013 (NCT01397968): This study evaluated the efficacy and safety of adjunctive Cenobamate 200 mg/day.[3]
- Study C017 (NCT01866111): This dose-response study assessed the efficacy and safety of adjunctive Cenobamate at doses of 100 mg, 200 mg, and 400 mg per day.[11]

An open-label extension study, Study C021 (NCT02535091), provided long-term efficacy and safety data.[12]

Experimental Protocols

3.2.1. Study Design (Exemplified by NCT01866111)

- Design: Multicenter, double-blind, randomized, placebo-controlled, dose-response study.[11]
- Patient Population: Adults (18-70 years) with uncontrolled focal seizures despite treatment with 1-3 ASMs. Patients were required to have a minimum of 8 focal seizures during the 8-week baseline period.[11][13]
- Treatment Phases:
 - Baseline Phase (8 weeks): Seizure frequency was documented to establish a baseline. [11]
 - Titration Phase (6 weeks): Patients were randomized to receive placebo or Cenobamate, with the dose gradually increased to the target maintenance dose.[11]
 - Maintenance Phase (12 weeks): Patients continued on their assigned stable dose of Cenobamate or placebo.[11]
- Primary Efficacy Endpoints:
 - Median percent change in seizure frequency per 28 days from baseline.[11]
 - Responder rate (percentage of patients with $\geq 50\%$ reduction in seizure frequency).[11]

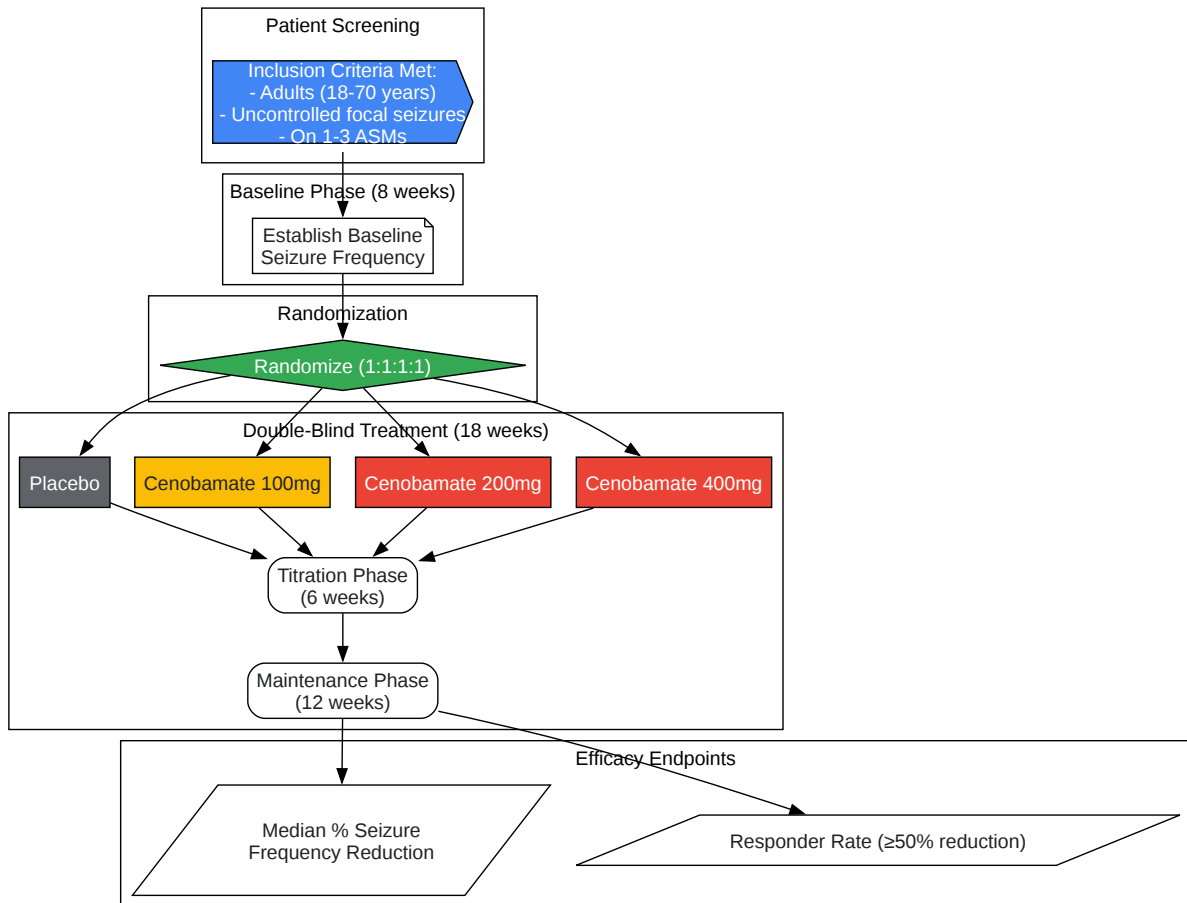

[Click to download full resolution via product page](#)

Caption: Workflow of a pivotal Phase 2 clinical trial for Cenobamate.

Quantitative Efficacy Data

The following tables summarize the key efficacy data from the pivotal clinical trials of Cenobamate.

Table 1: Median Percent Reduction in Seizure Frequency (per 28 days) from Baseline

Study	Placebo	Cenobamate 100 mg	Cenobamate 200 mg	Cenobamate 400 mg
NCT01397968[14]	21.5%	-	55.6%	-
NCT01866111[15]	24%	36%	55%	55%

Table 2: Responder Rate (≥50% Seizure Reduction) During Maintenance Phase

Study	Placebo	Cenobamate 100 mg	Cenobamate 200 mg	Cenobamate 400 mg
NCT01397968[14]	22.2%	-	55.6%	-
NCT01866111[15]	25%	40%	56%	64%

Table 3: Seizure-Free Rate During Maintenance Phase

Study	Placebo	Cenobamate 100 mg	Cenobamate 200 mg	Cenobamate 400 mg
NCT01397968[14]	8.8%	-	28.3%	-
NCT01866111[15]	1%	4%	11%	21%

Safety and Tolerability

The most common treatment-emergent adverse events reported in clinical trials were generally mild to moderate in severity and included somnolence, dizziness, headache, fatigue, and diplopia.[15] A slow titration schedule is recommended to improve tolerability.[16]

Conclusion

Cenobamate represents a significant advancement in the treatment of focal-onset seizures, including those associated with temporal lobe epilepsy. Its novel dual mechanism of action, targeting both excitatory and inhibitory pathways, translates into robust clinical efficacy, with a notable proportion of patients achieving high rates of seizure reduction and seizure freedom. The comprehensive preclinical and clinical data presented in this guide underscore the potential of Cenobamate as a valuable therapeutic option for patients with treatment-refractory TLE. Further research into its long-term effects and potential applications in other epilepsy syndromes is warranted.

Need Custom Synthesis?

BenchChem offers custom synthesis for rare earth carbides and specific isotopic labeling.

Email: info@benchchem.com or [Request Quote Online](#).

References

- [1. Cenobamate in refractory epilepsy: Overview of treatment options and practical considerations - PMC \[pmc.ncbi.nlm.nih.gov\]](#)
- [2. Cenobamate \(XCOPRI\): Can preclinical and clinical evidence provide insight into its mechanism of action? - PubMed \[pubmed.ncbi.nlm.nih.gov\]](#)
- [3. neurology.org \[neurology.org\]](#)
- [4. pharmacologydiscoveryservices.com \[pharmacologydiscoveryservices.com\]](#)
- [5. Pentylentetrazol Seizure Threshold Test \(mouse, rat\) \[panache.ninds.nih.gov\]](#)
- [6. meliordiscovery.com \[meliordiscovery.com\]](#)
- [7. researchgate.net \[researchgate.net\]](#)
- [8. 3.2.3. The 6 hertz \(6 Hz\) Psychomotor Seizure Test \[bio-protocol.org\]](#)

- [9. electrical amygdala kindling model in the rat: comparative study using two different stimulation protocols \[aesnet.org\]](#)
- [10. Kindling Models of Epileptogenesis for Developing Disease-Modifying Drugs for Epilepsy - PMC \[pmc.ncbi.nlm.nih.gov\]](#)
- [11. Safety and efficacy of adjunctive cenobamate \(YKP3089\) in patients with uncontrolled focal seizures: a multicentre, double-blind, randomised, placebo-controlled, dose-response trial - PubMed \[pubmed.ncbi.nlm.nih.gov\]](#)
- [12. researchgate.net \[researchgate.net\]](#)
- [13. ClinicalTrials.gov \[clinicaltrials.gov\]](#)
- [14. mdpi.com \[mdpi.com\]](#)
- [15. Cenobamate Reduces Seizure Frequency Significantly in Phase 2 Trial - - Practical Neurology \[practicalneurology.com\]](#)
- [16. Remarkably High Efficacy of Cenobamate in Adults With Focal-Onset Seizures: A Double-Blind, Randomized, Placebo-Controlled Trial - PMC \[pmc.ncbi.nlm.nih.gov\]](#)
- To cite this document: BenchChem. [Cenobamate: A Novel Dual-Mechanism Approach for Temporal Lobe Epilepsy]. BenchChem, [2026]. [Online PDF]. Available at: [\[https://www.benchchem.com/product/b607588/docs#cenobamate-a-novel-dual-mechanism-approach-for-temporal-lobe-epilepsy\]](https://www.benchchem.com/product/b607588/docs#cenobamate-a-novel-dual-mechanism-approach-for-temporal-lobe-epilepsy)

Disclaimer & Data Validity:

The information provided in this document is for Research Use Only (RUO) and is strictly not intended for diagnostic or therapeutic procedures. While BenchChem strives to provide accurate protocols, we make no warranties, express or implied, regarding the fitness of this product for every specific experimental setup.

Technical Support: The protocols provided are for reference purposes. Unsure if this reagent suits your experiment?

Need Industrial/Bulk Grade? [Request Custom Synthesis Quote](#)

BenchChem

Our mission is to be the trusted global source of essential and advanced chemicals, empowering scientists and researchers to drive progress in science and industry.

Contact

Address: 3281 E Guasti Rd

Ontario, CA 91761, United States

Phone: (601) 213-4426

Email: info@benchchem.com

[Contact our Ph.D. Support Team for a compatibility check](#)