

Aumolertinib: Preclinical and Early Research Insights into EGFR-Mutated Cancers

Author: BenchChem Technical Support Team. **Date:** December 2025

Compound of Interest

Compound Name: Aumolertinib

Cat. No.: B607974

[Get Quote](#)

An In-depth Technical Guide for Researchers and Drug Development Professionals

Introduction

Aumolertinib is a third-generation epidermal growth factor receptor (EGFR) tyrosine kinase inhibitor (TKI) that has demonstrated significant clinical activity in patients with non-small cell lung cancer (NSCLC) harboring EGFR mutations.[1][2] Developed to selectively target both sensitizing EGFR mutations (such as exon 19 deletions and L858R) and the T790M resistance mutation, **Aumolertinib** has shown a favorable safety profile with lower incidence of wild-type EGFR-related toxicities.[3][4] While its efficacy in NSCLC is well-documented, early research into its potential application for other cancer types with EGFR mutations is a growing area of interest for the oncology research community. This technical guide provides a comprehensive overview of the existing preclinical and early clinical data on **Aumolertinib**, with a focus on its activity against various EGFR mutations. Due to the current landscape of published research, the data presented herein is primarily derived from studies in NSCLC. However, the experimental protocols and signaling pathway information are broadly applicable to the investigation of **Aumolertinib** in other EGFR-driven malignancies.

I. Preclinical Data on Aumolertinib

In Vitro Kinase Inhibitory Activity

Aumolertinib has been evaluated for its inhibitory activity against a panel of EGFR mutations. The following table summarizes the half-maximal inhibitory concentrations (IC50) from in vitro

kinase assays.

EGFR Mutation	Aumolertinib IC50 (nmol/L)
L858R/T790M	0.58
Exon 19 Del/T790M	0.45
L858R	1.6
Exon 19 Del	1.3
Wild-Type EGFR	9.2

Data compiled from preclinical studies. The exact values may vary between different experimental setups.

In Vitro Cell Proliferation Assays

The anti-proliferative activity of **Aumolertinib** has been assessed in various cancer cell lines harboring different EGFR mutations. The IC50 values from these cell viability assays are presented below.

Cell Line	Cancer Type	EGFR Mutation	Aumolertinib IC50 (nmol/L)
H1975	NSCLC	L858R/T790M	1.8
PC-9	NSCLC	Exon 19 Del	2.5
HCC827	NSCLC	Exon 19 Del	3.1
A431	Epidermoid Carcinoma	Wild-Type (amplified)	>1000

Data compiled from preclinical studies. The exact values may vary between different experimental setups.

In Vivo Xenograft Models

The anti-tumor efficacy of **Aumolertinib** has been demonstrated in vivo using mouse xenograft models. The following table summarizes the tumor growth inhibition (TGI) in mice bearing tumors derived from human cancer cell lines.

Cell Line Xenograft	Cancer Type	EGFR Mutation	Aumolertinib Dose (mg/kg/day)	Tumor Growth Inhibition (%)
H1975	NSCLC	L858R/T790M	25	85
PC-9	NSCLC	Exon 19 Del	25	92

Data compiled from preclinical studies. The exact values may vary between different experimental setups.

II. Early Clinical Research in NSCLC

While the primary focus of this guide is on early research in other cancer types, the clinical data from NSCLC provides a strong rationale for exploring **Aumolertinib**'s potential in a broader range of EGFR-mutated tumors.

Phase I/II Study in T790M-Positive NSCLC

In a pivotal Phase I/II study, **Aumolertinib** demonstrated significant efficacy in patients with advanced NSCLC and the EGFR T790M resistance mutation who had progressed on prior EGFR TKI therapy.

Parameter	Result
Objective Response Rate (ORR)	68.9%
Disease Control Rate (DCR)	93.4%
Median Progression-Free Survival (PFS)	12.4 months

AENEAS Phase III Study (First-Line Treatment)

The AENEAS trial was a randomized, double-blind, Phase III study comparing **Aumolertinib** with Gefitinib as a first-line treatment for locally advanced or metastatic NSCLC with common EGFR mutations.

Parameter	Aumolertinib	Gefitinib
Median Progression-Free Survival (PFS)	19.3 months	9.9 months
Objective Response Rate (ORR)	73.8%	71.4%
Median Duration of Response (DoR)	18.1 months	8.3 months

III. Experimental Protocols

Cell Viability Assay (CellTiter-Glo®)

Objective: To determine the half-maximal inhibitory concentration (IC50) of **Aumolertinib** in cancer cell lines.

Methodology:

- Cell Seeding: Seed cancer cells in 96-well opaque-walled plates at a density of 3,000-5,000 cells per well in 100 µL of complete growth medium. Incubate for 24 hours at 37°C in a humidified atmosphere with 5% CO₂.
- Compound Treatment: Prepare serial dilutions of **Aumolertinib** in culture medium. Add 100 µL of the diluted compound to the respective wells, resulting in a final volume of 200 µL. Include vehicle-treated (DMSO) and untreated wells as controls.
- Incubation: Incubate the plates for 72 hours at 37°C and 5% CO₂.
- Assay Procedure:
 - Equilibrate the plate and its contents to room temperature for approximately 30 minutes.
 - Prepare the CellTiter-Glo® Reagent according to the manufacturer's instructions.

- Add 100 μ L of CellTiter-Glo® Reagent to each well.
- Mix the contents on an orbital shaker for 2 minutes to induce cell lysis.
- Incubate the plate at room temperature for 10 minutes to stabilize the luminescent signal.
- Data Acquisition: Measure the luminescence of each well using a plate reader.
- Data Analysis: Calculate the percentage of cell viability relative to the vehicle-treated control. Determine the IC50 value by plotting the percentage of viability against the logarithm of the drug concentration and fitting the data to a sigmoidal dose-response curve.

Western Blot for EGFR Phosphorylation

Objective: To assess the inhibitory effect of **Aumolertinib** on EGFR phosphorylation and downstream signaling pathways.

Methodology:

- Cell Culture and Treatment: Plate cells in 6-well plates and grow to 70-80% confluency. Serum-starve the cells for 12-24 hours. Treat the cells with varying concentrations of **Aumolertinib** or vehicle (DMSO) for 2-4 hours. Stimulate the cells with 50 ng/mL of human recombinant EGF for 15 minutes.
- Protein Extraction:
 - Wash the cells twice with ice-cold phosphate-buffered saline (PBS).
 - Lyse the cells in RIPA buffer supplemented with protease and phosphatase inhibitors.
 - Scrape the cells and collect the lysate.
 - Centrifuge the lysate at 14,000 rpm for 15 minutes at 4°C to pellet the cell debris.
 - Collect the supernatant containing the protein extract.
- Protein Quantification: Determine the protein concentration of each sample using a BCA protein assay kit.

- SDS-PAGE and Protein Transfer:
 - Denature 20-30 µg of protein from each sample by boiling in Laemmli sample buffer.
 - Separate the proteins by sodium dodecyl sulfate-polyacrylamide gel electrophoresis (SDS-PAGE).
 - Transfer the separated proteins to a polyvinylidene difluoride (PVDF) membrane.
- Immunoblotting:
 - Block the membrane with 5% non-fat dry milk or bovine serum albumin (BSA) in Tris-buffered saline with 0.1% Tween 20 (TBST) for 1 hour at room temperature.
 - Incubate the membrane with primary antibodies against phospho-EGFR (Tyr1068), total EGFR, phospho-AKT (Ser473), total AKT, phospho-ERK1/2 (Thr202/Tyr204), and total ERK1/2 overnight at 4°C. A loading control such as β-actin or GAPDH should also be used.
 - Wash the membrane three times with TBST.
 - Incubate the membrane with the appropriate horseradish peroxidase (HRP)-conjugated secondary antibody for 1 hour at room temperature.
 - Wash the membrane three times with TBST.
- Detection: Detect the protein bands using an enhanced chemiluminescence (ECL) detection system and an imaging system.

In Vivo Tumor Xenograft Model

Objective: To evaluate the anti-tumor efficacy of **Aumolertinib** in a preclinical in vivo model.

Methodology:

- Animal Model: Use 4-6 week old female athymic nude mice or other appropriate immunodeficient mice.

- Cell Implantation:
 - Harvest cancer cells (e.g., H1975 or PC-9) during their exponential growth phase.
 - Resuspend the cells in a 1:1 mixture of serum-free medium and Matrigel.
 - Subcutaneously inject 5×10^6 cells in a volume of 100-200 μL into the right flank of each mouse.
- Tumor Growth and Randomization:
 - Monitor tumor growth by measuring the tumor dimensions with calipers every 2-3 days.
 - Calculate tumor volume using the formula: $(\text{Length} \times \text{Width}^2) / 2$.
 - When the average tumor volume reaches 100-150 mm^3 , randomize the mice into treatment and control groups (n=8-10 mice per group).
- Drug Administration:
 - Prepare **Aumolertinib** in an appropriate vehicle (e.g., 0.5% methylcellulose).
 - Administer **Aumolertinib** orally once daily at the desired dose.
 - Administer the vehicle to the control group following the same schedule.
- Monitoring and Endpoint:
 - Continue to measure tumor volumes and body weights 2-3 times per week.
 - Monitor the animals for any signs of toxicity.
 - The study endpoint can be a predetermined tumor volume, a specific duration of treatment, or when the control tumors reach a certain size.
- Data Analysis:
 - Calculate the tumor growth inhibition (TGI) using the formula: $\text{TGI} (\%) = [1 - (\text{mean tumor volume of treated group at endpoint} / \text{mean tumor volume of control group at endpoint})] \times 100$

100.

- Plot the mean tumor volume \pm SEM for each group over time.
- Perform statistical analysis to determine the significance of the treatment effect.

IV. Signaling Pathways and Experimental Workflows

EGFR Signaling Pathway and Aumolertinib's Point of Inhibition

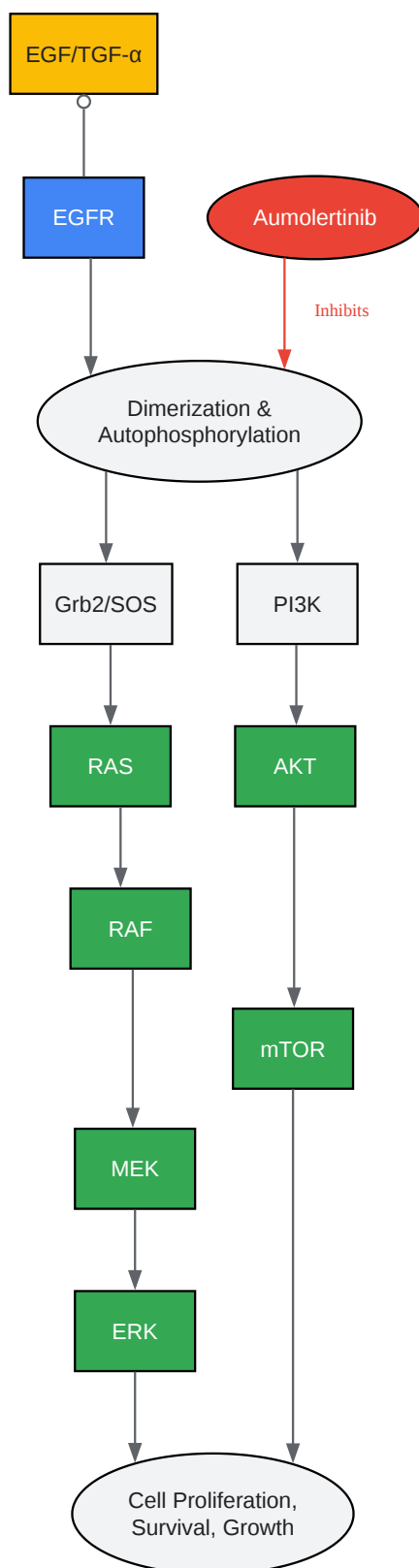

[Click to download full resolution via product page](#)

Caption: **Aumolertinib** inhibits EGFR autophosphorylation, blocking downstream signaling.

Experimental Workflow for In Vitro Evaluation of Aumolertinib

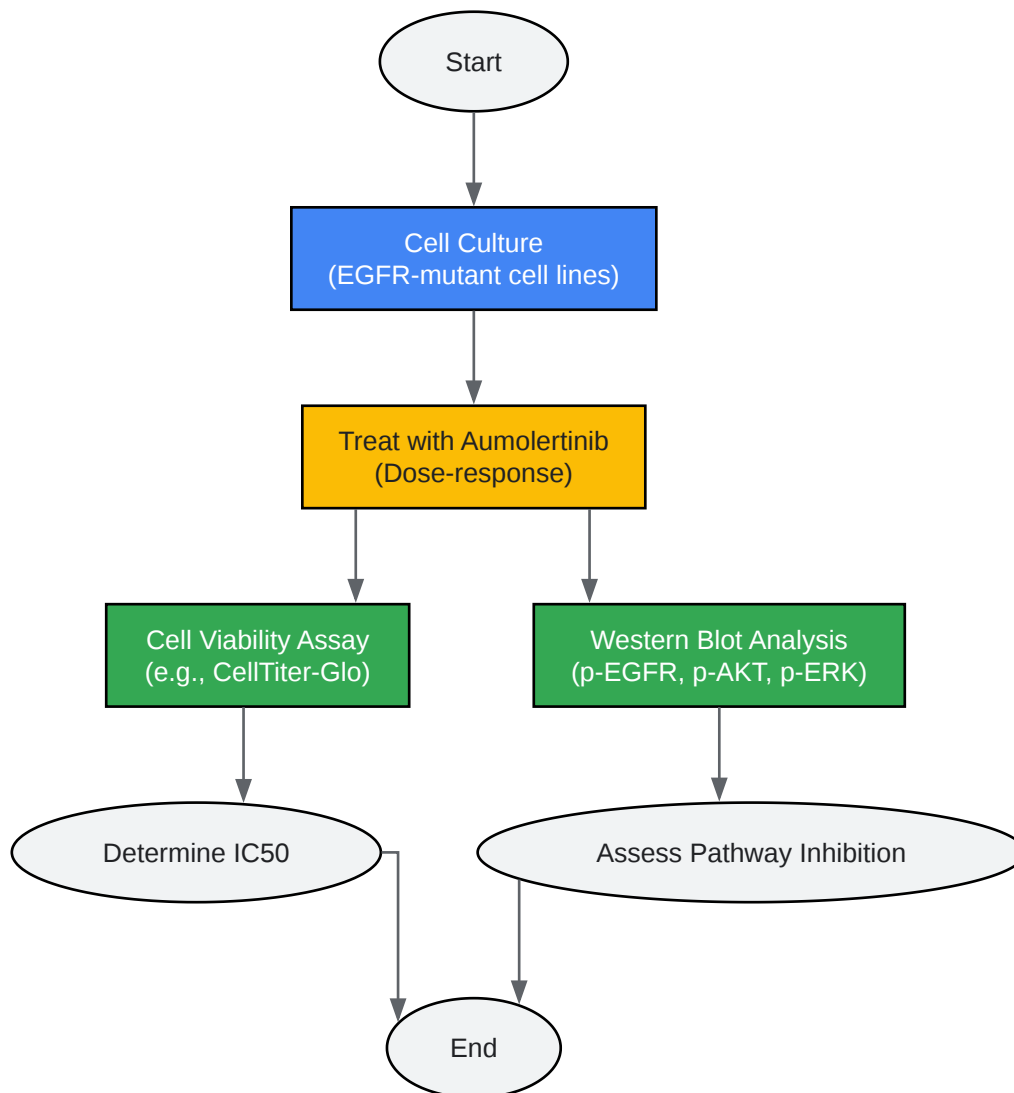

[Click to download full resolution via product page](#)

Need Custom Synthesis?

BenchChem offers custom synthesis for rare earth carbides and specific isotopic labeling.

Email: info@benchchem.com or [Request Quote Online](#).

References

- 1. ajmc.com [ajmc.com]
- 2. First-Line Aumolertinib in EGFR-Mutant Advanced Non-Small Cell Lung Cancer: A Multicenter Real-World Retrospective Study with a Four-Year Follow-Up - PMC [[pmc.ncbi.nlm.nih.gov](https://pubmed.ncbi.nlm.nih.gov/)]
- 3. pharmacytimes.com [pharmacytimes.com]
- 4. Antitumor activity of aumolertinib, a third-generation EGFR tyrosine kinase inhibitor, in non-small-cell lung cancer harboring uncommon EGFR mutations - PMC [[pmc.ncbi.nlm.nih.gov](https://pubmed.ncbi.nlm.nih.gov/)]
- To cite this document: BenchChem. [Aumolertinib: Preclinical and Early Research Insights into EGFR-Mutated Cancers]. BenchChem, [2025]. [Online PDF]. Available at: [<https://www.benchchem.com/product/b607974#early-research-on-aumolertinib-for-other-cancer-types-with-egfr-mutations>]

Disclaimer & Data Validity:

The information provided in this document is for Research Use Only (RUO) and is strictly not intended for diagnostic or therapeutic procedures. While BenchChem strives to provide accurate protocols, we make no warranties, express or implied, regarding the fitness of this product for every specific experimental setup.

Technical Support: The protocols provided are for reference purposes. Unsure if this reagent suits your experiment? [[Contact our Ph.D. Support Team for a compatibility check](#)]

Need Industrial/Bulk Grade? [Request Custom Synthesis Quote](#)

BenchChem

Our mission is to be the trusted global source of essential and advanced chemicals, empowering scientists and researchers to drive progress in science and industry.

Contact

Address: 3281 E Guasti Rd
Ontario, CA 91761, United States
Phone: (601) 213-4426
Email: info@benchchem.com