

Technical Support Center: Optimizing DCG-04 for Cell Labeling

Author: BenchChem Technical Support Team. **Date:** April 2026

Compound of Interest

Compound Name:	DCG04
CAS No.:	314263-42-8
Cat. No.:	B606991

[Get Quote](#)

Welcome to the technical support center for DCG-04, an activity-based probe for cysteine cathepsins. This guide provides detailed troubleshooting advice, frequently asked questions (FAQs), and experimental protocols to help researchers, scientists, and drug development professionals optimize their cell labeling experiments.

Frequently Asked Questions (FAQs) & Troubleshooting

This section addresses common issues and questions that may arise during the use of DCG-04.

Q1: What is the optimal concentration of DCG-04 for cell labeling?

A1: The optimal concentration of DCG-04 is highly dependent on the experimental system, including the cell type, whether you are using cell lysates or live cells, and the abundance of active cathepsins. A good starting point for labeling in cell lysates is a concentration range of 1-10 μ M. For live cells, concentrations may vary, and optimization is critical. For example, some studies have used \sim 10 μ M for cultured cells, while others have used 1 μ M for specific live-cell

imaging applications with modified probes[1][2]. It is always recommended to perform a dose-response experiment to determine the concentration that yields the best signal-to-noise ratio for your specific model.

Q2: Why is my signal weak or absent, especially in live cells?

A2: Weak or no signal can stem from several factors:

- **Poor Cell Permeability:** The standard biotinylated form of DCG-04 has poor permeability across intact cell membranes, which can preclude its effective use in living cells[2]. For live-cell experiments, consider using fluorophore-modified derivatives of DCG-04 or alternative probes designed for better cell penetration[2].
- **Low Enzyme Activity:** The target cathepsins may have low activity in your sample. Ensure that your lysis and labeling buffers have the optimal pH (typically acidic, e.g., pH 5.5) and contain a reducing agent like DTT to maintain the active-site cysteine in a reduced state[3].
- **Inactive Probe:** Ensure the probe has been stored correctly and has not degraded.
- **Insufficient Incubation Time:** Labeling is time-dependent. While 30 minutes is often sufficient for lysates, optimization may be required[3].

Q3: I'm observing high background fluorescence or non-specific bands. How can I reduce this?

A3: High background can obscure your specific signal. Here are some troubleshooting steps:

- **Reduce Probe Concentration:** The most common cause of high background is an excessive concentration of the probe. Perform a titration to find the lowest effective concentration.
- **Thorough Washing:** For live-cell imaging, ensure you wash the cells thoroughly after labeling to remove any excess unbound probe[3].
- **Optimize Blocking:** For Western blot detection, ensure proper blocking of the membrane to prevent non-specific binding of the streptavidin conjugate.
- **Use pH-Activatable Probes:** For live-cell imaging targeting acidic organelles like lysosomes, consider using DCG-04 conjugates with pH-activatable fluorophores. These probes only

become fluorescent in the low-pH environment of the target compartment, significantly reducing background from other cellular areas[1].

Q4: Is DCG-04 toxic to my cells?

A4: Like many chemical probes, DCG-04 can exhibit cytotoxicity at high concentrations or with prolonged exposure. Since it irreversibly binds to and inhibits a class of proteases crucial for cellular function, off-target effects and cellular stress can occur. To minimize cytotoxicity:

- Use the lowest effective concentration possible.
- Minimize the incubation time.
- Perform a cell viability assay (e.g., MTT or Trypan Blue exclusion) in parallel with your labeling experiment to assess the impact of the probe on your cells at different concentrations and incubation times.

Q5: What is the difference between using DCG-04 in cell lysates versus live cells?

A5: The primary difference is probe accessibility.

- Cell Lysates: The cell membrane is disrupted, allowing DCG-04 direct access to intracellular proteases. Standard biotinylated DCG-04 is robust for in vitro detection in lysates[2].
- Live Cells: The probe must cross the cell membrane. As standard DCG-04 is cell-impermeable, labeling often requires modified, cell-permeable versions (e.g., with ester groups or fluorescent tags) or strategies to facilitate uptake, such as conjugation to a ligand that mediates endocytosis[1][2][4].

Q6: What are the essential controls for a DCG-04 labeling experiment?

A6: To ensure the specificity of your labeling, the following controls are critical:

- Unlabeled Control: A sample of cells or lysate that has not been treated with DCG-04 to assess endogenous biotinylated proteins or autofluorescence.
- Competition Control: Pre-incubate your sample with a broad-spectrum, irreversible cysteine protease inhibitor (like E-64) before adding DCG-04. A significant reduction in the labeling

signal indicates that DCG-04 is specifically targeting active cysteine proteases[4].

- Heat-Inactivated Control: A sample of lysate that has been boiled before labeling. This will denature the enzymes, and no active labeling should be observed.

Quantitative Data Summary

The following table summarizes DCG-04 concentrations and conditions used in various studies. This data should serve as a starting point for experimental design.

Probe/Inhibitor	Concentration	System Type	Incubation Time	Temperature	Key Findings/Notes
DCG-04	~10 μ M	Cultured Cells (Live)	Not specified	Not specified	Concentration suggested for yielding distinct bands of active proteases.[2]
BODIPY-DCG-04	1 μ M	Immature Mouse Dendritic Cells (Live)	Not specified	Not specified	Used for live-cell fluorescence microscopy with a modified probe.[1]
MGP140 (DCG-04 derivative)	5 μ M	KG-1 Cells (Live)	30 min	37 $^{\circ}$ C	Used for imaging cathepsin activity in live cells.[3]
DCG-04	100 μ M	Purified Cathepsin X	30 min	Room Temp	Used as a competitive inhibitor to block probe labeling.[3]
Azido-E-64 (E-64 derivative)	13 μ M	Live Macrophages	Not specified	Not specified	Concentration that completely blocked subsequent DCG-04 labeling.[4]

Experimental Protocols & Methodologies

Protocol 1: Labeling of Active Cysteine Cathepsins in Cell Lysates

This protocol is adapted for general use with cell lysates.

- Cell Lysis:
 - Harvest cells and wash with cold PBS.
 - Lyse the cell pellet in an appropriate lysis buffer (e.g., 50 mM sodium acetate, pH 5.5, 0.1% Triton X-100, 1 mM DTT).
 - Centrifuge the lysate at 14,000 x g for 15 minutes at 4°C to pellet cellular debris.
 - Collect the supernatant and determine the protein concentration (e.g., via BCA assay).
- Labeling Reaction:
 - Dilute the protein lysate to a final concentration of 1-2 mg/mL in reaction buffer (50 mM NaOAc, 2 mM DTT, 5 mM MgCl₂, pH 5.5)[3].
 - Add DCG-04 to a final concentration of 1-10 μM. It is recommended to test a range of concentrations initially.
 - For a competition control, pre-incubate a separate aliquot of lysate with 50 μM E-64 for 15 minutes before adding DCG-04.
 - Incubate all samples for 30-60 minutes at room temperature[3].
- Sample Analysis:
 - Stop the reaction by adding 4x SDS-PAGE loading buffer and boiling for 5 minutes.
 - Separate the proteins by SDS-PAGE.
 - Transfer the proteins to a PVDF or nitrocellulose membrane.

- Block the membrane, then probe with a streptavidin-HRP conjugate to detect biotinylated proteins.
- Visualize the bands using a chemiluminescent substrate.

Protocol 2: Labeling of Active Cysteine Cathepsins in Live Cells (with a Cell-Permeable Probe)

This protocol provides a general workflow for live-cell labeling, assuming a cell-permeable, fluorescently-tagged DCG-04 derivative is used.

- Cell Preparation:
 - Plate cells on a suitable imaging dish (e.g., glass-bottom plates) and allow them to adhere overnight.
- Labeling:
 - Prepare a working solution of the fluorescent DCG-04 probe in complete cell culture media. A starting concentration of 1-5 μM is recommended for initial tests[3].
 - For a competition control, pre-treat cells with a cell-permeable inhibitor (e.g., 100 μM JPM-OEt or 10 μM GB111-NH₂) for 1 hour at 37°C before adding the probe[3].
 - Remove the media from the cells and replace it with the probe-containing media.
 - Incubate for 30-60 minutes at 37°C in a CO₂ incubator[3].
- Washing and Imaging:
 - Aspirate the probe-containing media.
 - Wash the cells 2-3 times with fresh, pre-warmed complete media to remove excess unbound probe[3]. A prolonged final wash (1-3 hours) may be necessary to improve the signal-to-noise ratio[3].
 - Add fresh media or a suitable imaging buffer to the cells.

- Image the cells using a fluorescence microscope with the appropriate filter sets for the fluorophore used.

Visualizations

DCG-04 Mechanism of Action

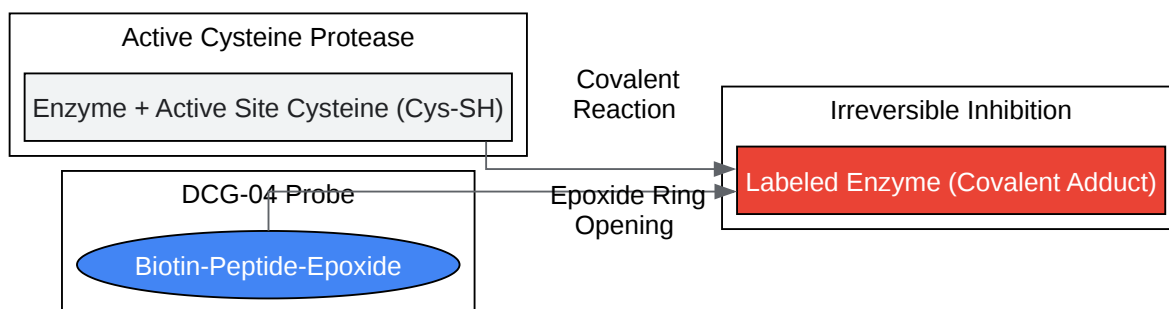

[Click to download full resolution via product page](#)

Caption: Covalent modification of a protease active site by the DCG-04 probe.

Workflow for Optimizing DCG-04 Concentration

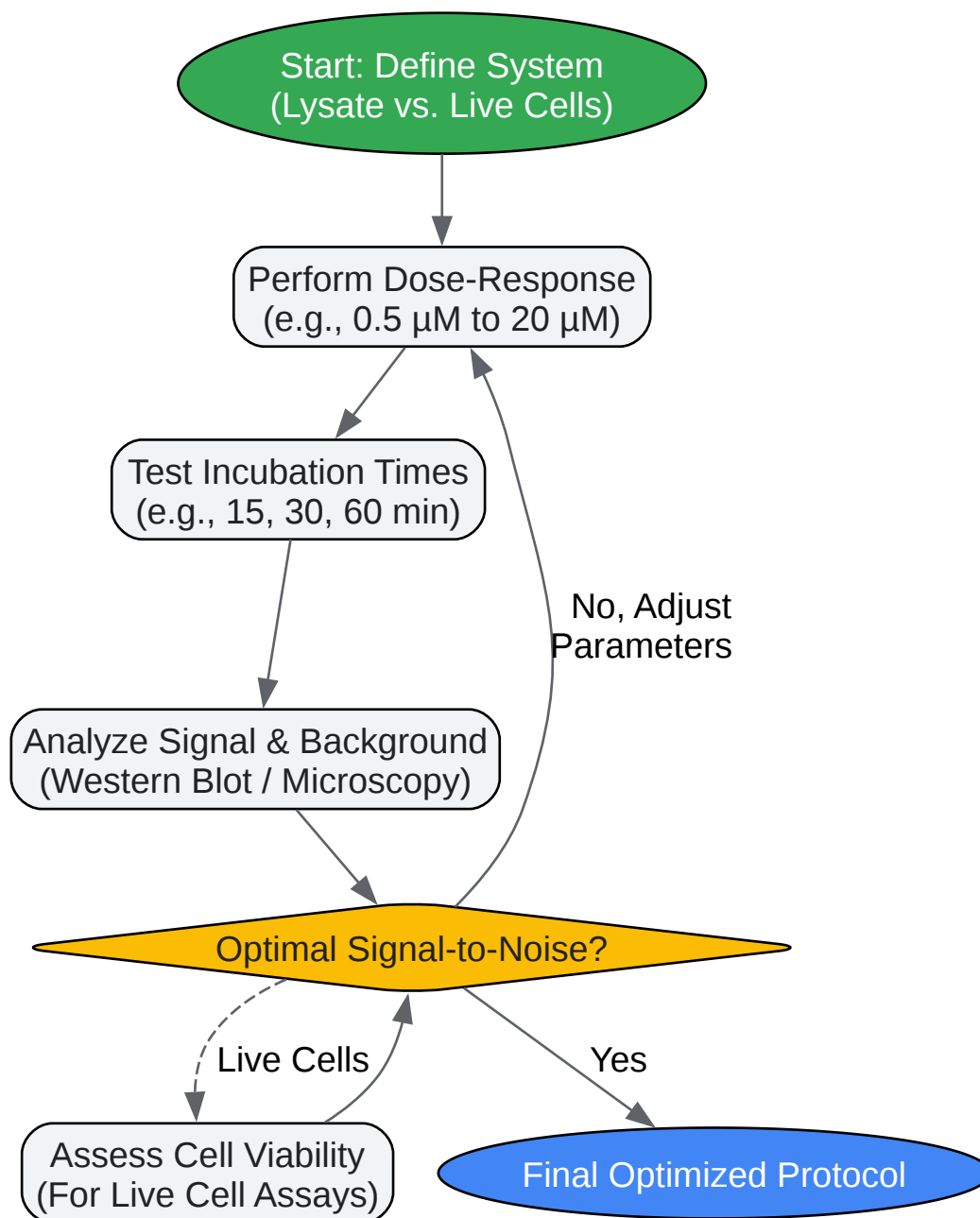

[Click to download full resolution via product page](#)

Caption: Logical workflow for optimizing DCG-04 concentration in an experiment.

Need Custom Synthesis?

BenchChem offers custom synthesis for rare earth carbides and specific isotopic labeling.

Email: info@benchchem.com or [Request Quote Online](#).

References

- [1. researchgate.net \[researchgate.net\]](#)
- [2. medkoo.com \[medkoo.com\]](#)
- [3. Development of activity-based probes for cathepsin X - PMC \[pmc.ncbi.nlm.nih.gov\]](#)
- [4. renaissance.stonybrookmedicine.edu \[renaissance.stonybrookmedicine.edu\]](#)
- To cite this document: BenchChem. [Technical Support Center: Optimizing DCG-04 for Cell Labeling]. BenchChem, [2026]. [Online PDF]. Available at: [\[https://www.benchchem.com/product/b606991/docs#technical-support-center-optimizing-dcg-04-for-cell-labeling\]](https://www.benchchem.com/product/b606991/docs#technical-support-center-optimizing-dcg-04-for-cell-labeling)

Disclaimer & Data Validity:

The information provided in this document is for Research Use Only (RUO) and is strictly not intended for diagnostic or therapeutic procedures. While BenchChem strives to provide accurate protocols, we make no warranties, express or implied, regarding the fitness of this product for every specific experimental setup.

Technical Support: The protocols provided are for reference purposes. Unsure if this reagent suits your experiment?

Need Industrial/Bulk Grade? [Request Custom Synthesis Quote](#)

BenchChem

Our mission is to be the trusted global source of essential and advanced chemicals, empowering scientists and researchers to drive progress in science and industry.

Contact

Address: 3281 E Guasti Rd
Ontario, CA 91761, United States
Phone: (601) 213-4426
Email: info@benchchem.com

Contact our Ph.D. Support Team for a compatibility check