

Technical Support Center: BI-167107- β 2AR

Complex Stability

Author: BenchChem Technical Support Team. **Date:** December 2025

Compound of Interest

Compound Name: BI-167107

Cat. No.: B606075

[Get Quote](#)

Welcome to the technical support center for researchers working with the **BI-167107- β 2AR** complex. This resource provides troubleshooting guides, frequently asked questions (FAQs), and detailed protocols to help you improve the stability of the complex for structural and functional studies.

Frequently Asked Questions (FAQs) & Troubleshooting

Q1: My purified **BI-167107- β 2AR** complex is unstable and aggregates quickly. What is the first thing I should check?

A1: The intrinsic stability of the β 2-adrenergic receptor (β 2AR) is low, especially in its active state. The first and most critical factor is ensuring the presence of a saturating concentration of a high-affinity agonist. **BI-167107** is an excellent choice due to its high potency and slow dissociation rate, which are crucial for stabilizing the active-state conformation.[1][2][3] Efforts to study agonist-bound active-state GPCRs are often hampered by the inherent instability of this state without a binding partner like a G protein.[3]

- **Troubleshooting Tip:** Confirm the concentration and purity of your **BI-167107** stock. During purification, ensure the ligand is present in all buffers at a concentration well above its K_d (dissociation constant) to prevent dissociation. The dissociation half-life of **BI-167107** is over 30 hours, which is highly favorable for maintaining complex integrity.[3]

Q2: I'm using **BI-167107**, but the complex is still not stable enough for structural studies. What protein engineering strategies can I employ?

A2: Several protein engineering strategies have been successfully used to stabilize the β 2AR. The most common and effective is the use of a fusion partner, such as T4 Lysozyme (T4L).

- T4L Fusion: T4L is a small, stable, and highly crystallizable protein. Fusing it to the β 2AR can dramatically improve stability and facilitate crystallization by providing a larger, rigid hydrophilic surface for crystal lattice contacts.
 - N-terminal Fusion: Fusing T4L to the N-terminus of the β 2AR has been shown to facilitate crystallization without the need for thermostabilizing mutations or other stabilizing proteins.
 - ICL3 Replacement: Replacing the flexible and proteolytically sensitive third intracellular loop (ICL3) with T4L is another widely used strategy.
- Thermostabilizing Mutations: Introducing point mutations can significantly enhance the receptor's thermal stability. For instance, mutating a highly conserved glutamate in transmembrane helix 3 (E122W) has been shown to increase the yield of functionally folded β 2AR and enhance its thermal half-life by over 9-fold at 37°C without altering its core pharmacological properties. Combining multiple single stabilizing mutations can further improve stability.

Q3: How can I lock the **BI-167107**- β 2AR complex in a specific, stable conformation?

A3: To stabilize a specific conformation, particularly the active state, you can use an accessory protein that recognizes and binds to that state. Nanobodies are highly effective for this purpose.

- Nanobody 80 (Nb80): Nb80 is a single-domain antibody fragment that was specifically developed to recognize the active state of β 2AR. It functions as a G-protein surrogate, binding to the intracellular face of the receptor and allosterically stabilizing the high-affinity, active conformation. The combination of the full agonist **BI-167107** and Nb80 is a proven method for obtaining a stable, active-state β 2AR complex suitable for crystallography and other structural methods.

Q4: My complex seems stable during purification but fails during crystallization trials. What should I consider?

A4: Crystallization of membrane proteins like β 2AR is challenging due to their hydrophobic surfaces.

- **Detergent Choice:** The detergent used to solubilize the receptor is critical. While dodecylmaltoside (DDM) is common, detergents like MNG-3 may offer increased receptor stability for certain applications.
- **Crystallization Method:** Traditional vapor diffusion methods can be challenging. Using lipidic mesophases, such as the lipidic cubic phase (LCP), often yields better results for GPCRs. The LCP environment mimics a more native-like membrane bilayer, which can help maintain the receptor's structural integrity.
- **Fusion Partners:** As mentioned in A2, the T4L fusion strategy is primarily designed to overcome crystallization difficulties by providing stable, hydrophilic surfaces that promote crystal packing interactions.

Q5: How can I quantitatively measure the stability of my β 2AR construct and assess the effect of different ligands or mutations?

A5: A thermostability assay is the standard method for this. The ThermoBRET assay is a modern, high-throughput method that can be used on non-purified GPCRs. It measures protein unfolding by detecting Bioluminescence Resonance Energy Transfer (BRET) between a Nanoluciferase (Nluc) tag fused to the receptor and a fluorescent dye that binds to cysteine residues exposed upon denaturation. By heating the sample across a temperature gradient, you can determine the melting temperature (T_m), which is a direct measure of thermostability. A higher T_m indicates greater stability. This allows you to rapidly screen different ligands, mutations, or buffer conditions to find the most stabilizing ones.

Quantitative Data Summary

The following tables summarize key quantitative data for **BI-167107** and the effects of stabilizing mutations on β 2AR.

Table 1: Binding and Functional Parameters of **BI-167107**

Parameter	Value	Receptor	Reference
Binding Affinity (Kd)	84 pM	Human β2AR	
Dissociation Half-Life ($t_{1/2}$)	> 30 hours	Human β 2AR	
cAMP Accumulation (EC50)	0.05 nM	Human β 2AR	
Off-target Affinity (IC50)	3.2 nM	Human β 1AR (agonist)	

| Off-target Affinity (IC50) | 32 nM | Human α 1A (antagonist) | |

Table 2: Effect of E122W Mutation on β 2AR Properties

Parameter	Wild-Type (WT) β 2AR	E122W Mutant β 2AR	Fold Change	Reference
Thermal Half-Life (at 37°C)	~10 min	~93 min	9.3-fold increase	
Functional Folding Yield	Normalized to 1	~5-fold increase	5-fold increase	
Isoproterenol Affinity (Ki)	323.8 \pm 26.3 nM	622.3 \pm 62.3 nM	~2-fold decrease	

| Isoproterenol Potency (EC50) | 40.6 \pm 1.1 nM | 43.1 \pm 1.2 nM | No significant change | |

Experimental Protocols & Visualizations

Protocol: GPCR Thermostability Assessment using ThermoBRET

This protocol provides a generalized method for measuring the thermostability (T_m) of Nluc-tagged β 2AR constructs in non-purified membranes, based on the ThermoBRET assay.

Objective: To determine the melting temperature (T_m) of a β 2AR construct and assess the stabilizing effect of **BI-167107**.

Materials:

- Cell membranes from HEK293 or Sf9 cells expressing N-terminally Nluc-tagged β 2AR.
- Assay Buffer: PBS or HEPES-buffered saline.
- Detergent for solubilization (e.g., DDM, MNG-3).
- **BI-167107** stock solution.
- Thiol-reactive fluorescent dye (e.g., sulfo-Cy3 maleimide).
- PCR thermocycler for temperature gradient.
- Plate reader capable of measuring BRET.

Methodology:

- Membrane Solubilization:
 - Thaw frozen cell membrane pellets on ice.
 - Resuspend membranes in Assay Buffer containing your chosen detergent (e.g., 1% DDM) and protease inhibitors.
 - Incubate on a rotator at 4°C for 1 hour to solubilize membrane proteins.
 - Centrifuge at $>100,000 \times g$ for 30-60 minutes at 4°C to pellet insoluble material.
 - Carefully collect the supernatant containing the solubilized receptor.
- Assay Plate Preparation:
 - Prepare serial dilutions of **BI-167107** in Assay Buffer.
 - In a 384-well plate, add the solubilized receptor preparation.

- Add the **BI-167107** dilutions or vehicle control to the wells.
- Add the thiol-reactive dye to all wells. The final concentration must be optimized, but is typically in the low micromolar range.
- Mix gently and incubate at room temperature for 15 minutes in the dark.
- Thermal Denaturation:
 - Seal the plate and place it in a thermocycler.
 - Apply a temperature gradient for a fixed time (e.g., 3 minutes per temperature step) across a range such as 25°C to 65°C.
- BRET Measurement:
 - After the heat challenge, allow the plate to cool to room temperature.
 - Measure the BRET signal on a compatible plate reader. The signal is generated by energy transfer from the Nluc tag to the dye that has bound to cysteines exposed during unfolding.
- Data Analysis:
 - Plot the BRET ratio as a function of temperature for each condition.
 - Fit the data to a sigmoidal dose-response curve (e.g., Boltzmann equation).
 - The inflection point of the curve represents the melting temperature (T_m). A rightward shift in the curve and a higher T_m in the presence of **BI-167107** indicates ligand-induced stabilization.

Diagrams

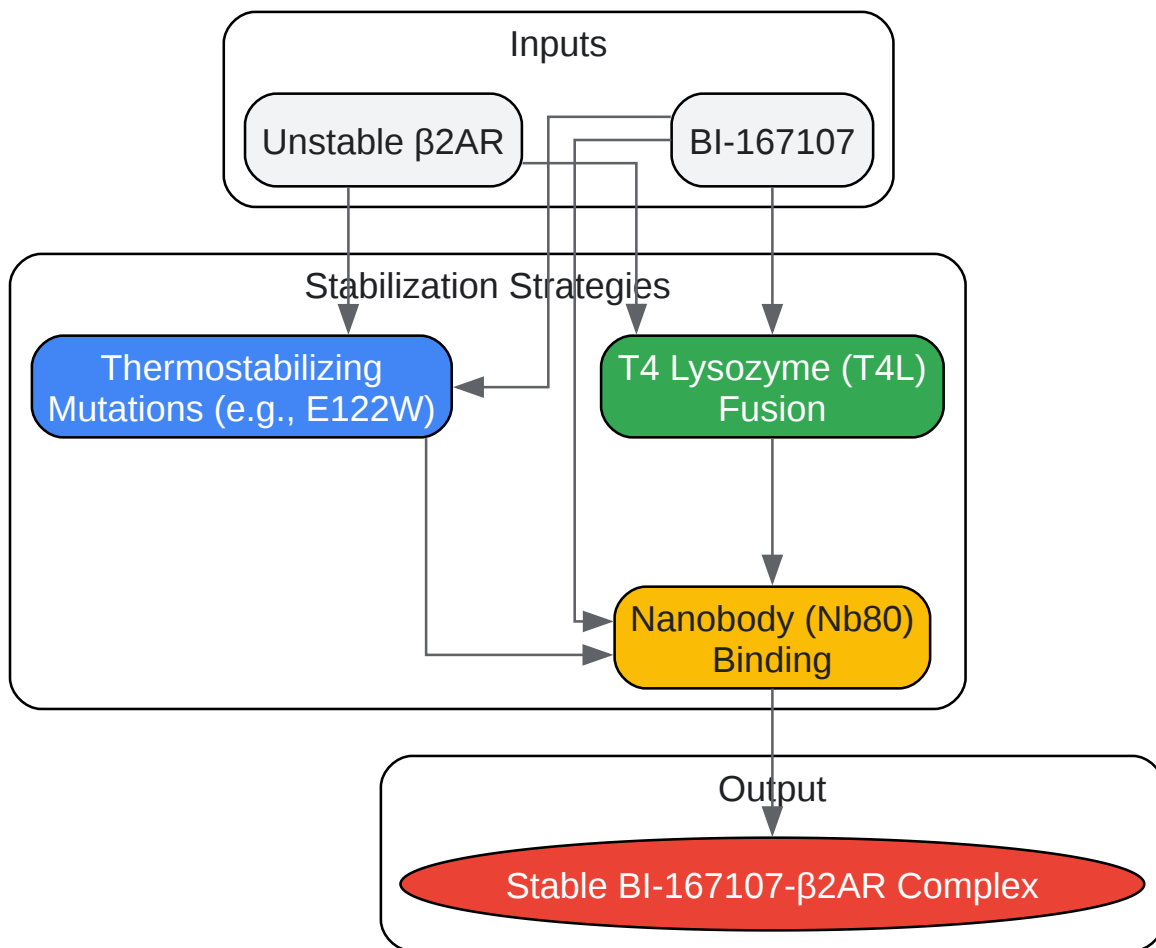

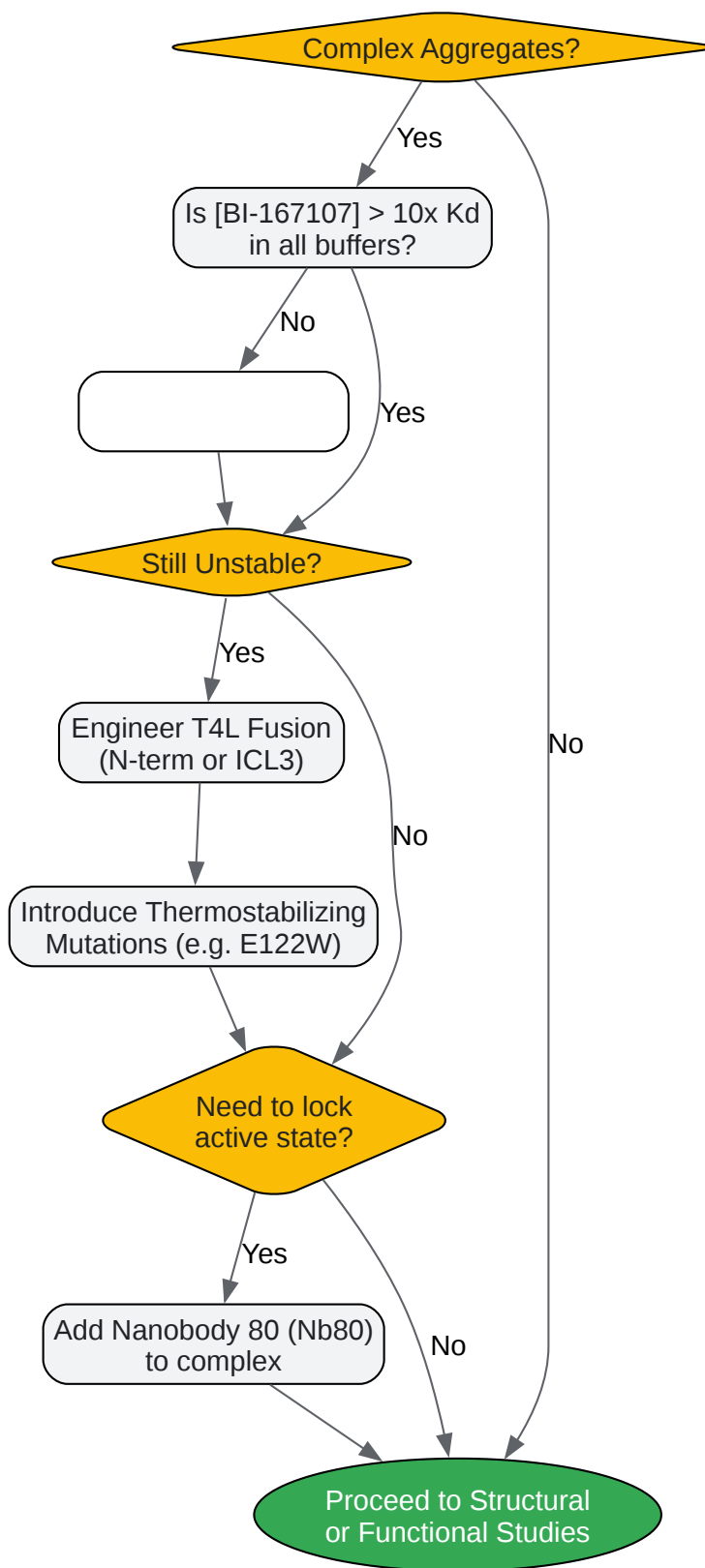

[Click to download full resolution via product page](#)

Need Custom Synthesis?

BenchChem offers custom synthesis for rare earth carbides and specific isotopic labeling.

Email: info@benchchem.com or [Request Quote Online](#).

References

- 1. biblio.vub.ac.be [biblio.vub.ac.be]
- 2. Structure of a nanobody-stabilized active state of the β 2 adrenoceptor - PMC [pmc.ncbi.nlm.nih.gov]
- 3. Pardon Our Interruption [opnme.com]
- To cite this document: BenchChem. [Technical Support Center: BI-167107- β 2AR Complex Stability]. BenchChem, [2025]. [Online PDF]. Available at: [https://www.benchchem.com/product/b606075#improving-the-stability-of-the-bi-167107-2ar-complex]

Disclaimer & Data Validity:

The information provided in this document is for Research Use Only (RUO) and is strictly not intended for diagnostic or therapeutic procedures. While BenchChem strives to provide accurate protocols, we make no warranties, express or implied, regarding the fitness of this product for every specific experimental setup.

Technical Support: The protocols provided are for reference purposes. Unsure if this reagent suits your experiment? [[Contact our Ph.D. Support Team for a compatibility check](#)]

Need Industrial/Bulk Grade? [Request Custom Synthesis Quote](#)

BenchChem

Our mission is to be the trusted global source of essential and advanced chemicals, empowering scientists and researchers to drive progress in science and industry.

Contact

Address: 3281 E Guasti Rd

Ontario, CA 91761, United States

Phone: (601) 213-4426

Email: info@benchchem.com