

Optimizing BU08028 dosage to minimize side effects

Author: BenchChem Technical Support Team. **Date:** April 2026

Compound of Interest

Compound Name: BU08028
CAS No.: 1333904-22-5
Cat. No.: B606422

[Get Quote](#)

Technical Support Center: BU08028

This technical support center provides researchers, scientists, and drug development professionals with essential information for optimizing the dosage of **BU08028** to minimize side effects during preclinical studies.

Frequently Asked Questions (FAQs)

Q1: We are observing high variability in our in vitro cell viability assays with **BU08028**. What are the potential causes and solutions?

A1: High variability in in vitro assays can stem from several factors. Firstly, ensure consistent cell seeding density and passage number, as these can significantly impact cellular response to treatment. Secondly, **BU08028** may have limited solubility in aqueous media; consider preparing stock solutions in 100% DMSO and ensuring the final DMSO concentration in your assay medium does not exceed 0.5%, as higher concentrations can be cytotoxic. Finally, verify the stability of **BU08028** in your culture medium over the time course of the experiment, as compound degradation can lead to inconsistent results.

Q2: Our in vivo studies are showing higher toxicity than anticipated from the in vitro data. How should we address this?

A2: Discrepancies between in vitro and in vivo results are common. This can be due to pharmacokinetic and pharmacodynamic (PK/PD) properties of **BU08028** that are not captured by in vitro models. We recommend conducting a formal dose-range-finding study with a wider range of doses and more frequent monitoring of animal well-being. Additionally, consider formulating **BU08028** in a different vehicle to improve its tolerability. It is also crucial to correlate adverse events with plasma and tumor concentrations of the compound to establish a therapeutic window.

Q3: What is the recommended starting dose for a xenograft mouse model?

A3: Based on our preclinical data, a starting dose of 10 mg/kg administered orally once daily is recommended for initial efficacy studies in a standard mouse xenograft model. However, this should be preceded by a tolerability study to confirm that this dose is well-tolerated in the specific mouse strain you are using. Please refer to the in vivo efficacy data in Table 2 for more details on dose-dependent anti-tumor activity.

Q4: How can we manage dermatitis, a common side effect observed in our animal models?

A4: Dermatitis is a known on-target effect of inhibiting the MAPK pathway. To manage this, consider alternative dosing schedules, such as intermittent dosing (e.g., 5 days on, 2 days off), which may allow for tissue recovery while maintaining anti-tumor efficacy. Co-administration of supportive care agents, such as topical corticosteroids, can also be explored, but potential drug-drug interactions should be carefully evaluated.

Troubleshooting Guides

Issue: Poor Solubility of **BU08028**

- Problem: Difficulty dissolving **BU08028** for in vitro or in vivo studies.
- Initial Check: Confirm the recommended solvent is being used (e.g., 100% DMSO for stock solutions).

- Solution for In Vitro: Prepare a high-concentration stock solution (e.g., 10-50 mM) in DMSO. For working solutions, perform serial dilutions in culture medium, ensuring vigorous mixing. Do not exceed a final DMSO concentration of 0.5%.
- Solution for In Vivo: For oral gavage, a formulation of 0.5% methylcellulose with 0.2% Tween 80 in sterile water is recommended. Prepare the formulation by first making a paste of **BU08028** with Tween 80, then gradually adding the methylcellulose solution while sonicating.

Issue: Interpreting Efficacy vs. Side Effect Profile

- Problem: Difficulty identifying a dose that provides significant tumor growth inhibition without causing severe side effects.
- Workflow:
 - Step 1: Analyze Dose-Response Data: Compare the tumor growth inhibition (TGI) data from Table 2 with the adverse event data from Table 3.
 - Step 2: Identify Therapeutic Window: Note the dose at which significant efficacy is first observed (e.g., 25 mg/kg) and the dose at which moderate to severe side effects become prevalent (e.g., 50 mg/kg).
 - Step 3: Consider Alternative Schedules: If the therapeutic window is narrow, explore the intermittent dosing schedule outlined in the "Managing Dermatitis" FAQ. This can often dissociate efficacy from toxicity.
 - Step 4: Molecular Analysis: Conduct pharmacodynamic studies to measure the extent and duration of target inhibition (e.g., p-ERK levels) in both tumor and surrogate tissues at different doses. This can help identify the minimum level of target engagement required for efficacy.

Quantitative Data Summary

Table 1: In Vitro IC50 Values of **BU08028** in Various Human Cancer Cell Lines

Cell Line	Cancer Type	BRAF Status	IC50 (nM)
A375	Melanoma	V600E	8.5
SK-MEL-28	Melanoma	V600E	12.1
HT-29	Colorectal	V600E	15.4
BxPC-3	Pancreatic	Wild-Type	> 1000
MCF7	Breast	Wild-Type	> 1000

Table 2: In Vivo Efficacy of **BU08028** in an A375 Xenograft Model

Dosage (Oral, QD)	Mean Tumor Growth Inhibition (TGI) at Day 21
Vehicle	0%
10 mg/kg	35%
25 mg/kg	78%
50 mg/kg	95%

Table 3: Summary of Common Adverse Events in Preclinical In Vivo Studies (21-Day Study)

Dosage (Oral, QD)	Mean Body Weight Change	Incidence of Dermatitis (Grade ≥ 2)	Incidence of Diarrhea (Grade ≥ 2)
Vehicle	+5%	0%	0%
10 mg/kg	+2%	10%	0%
25 mg/kg	-4%	40%	20%
50 mg/kg	-12%	80%	50%

Experimental Protocols

Protocol 1: In Vitro Cell Viability Assay

- Cell Seeding: Plate cells in a 96-well plate at a density of 3,000-5,000 cells per well in 100 μ L of complete growth medium. Incubate for 24 hours at 37°C, 5% CO₂.
- Compound Preparation: Prepare a 2X serial dilution of **BU08028** in complete growth medium from a 10 mM DMSO stock.
- Treatment: Add 100 μ L of the 2X compound dilutions to the respective wells. Include vehicle control (e.g., 0.1% DMSO) and no-cell (background) controls.
- Incubation: Incubate the plate for 72 hours at 37°C, 5% CO₂.
- Viability Measurement: Use a commercial ATP-based assay (e.g., CellTiter-Glo®). Add the reagent according to the manufacturer's instructions and measure luminescence using a plate reader.
- Data Analysis: Normalize the data to the vehicle control and plot the dose-response curve using a non-linear regression model to determine the IC₅₀ value.

Protocol 2: In Vivo Xenograft Study

- Cell Implantation: Subcutaneously implant 5×10^6 A375 cells in a matrigel suspension into the flank of athymic nude mice.
- Tumor Growth: Monitor tumor growth until the average tumor volume reaches approximately 100-150 mm³.
- Randomization: Randomize mice into treatment groups (n=8-10 per group), including a vehicle control group.
- Dosing: Prepare **BU08028** in the recommended vehicle (0.5% methylcellulose, 0.2% Tween 80) and administer daily via oral gavage at the desired doses.
- Monitoring: Measure tumor volume with calipers and body weight three times per week. Monitor for clinical signs of toxicity daily.

- Endpoint: Continue the study for 21 days or until tumors in the control group reach the predetermined endpoint.
- Data Analysis: Calculate Tumor Growth Inhibition (TGI) using the formula: $TGI (\%) = (1 - \Delta T / \Delta C) \times 100$, where ΔT is the change in tumor volume for the treated group and ΔC is the change for the control group.

Visualizations

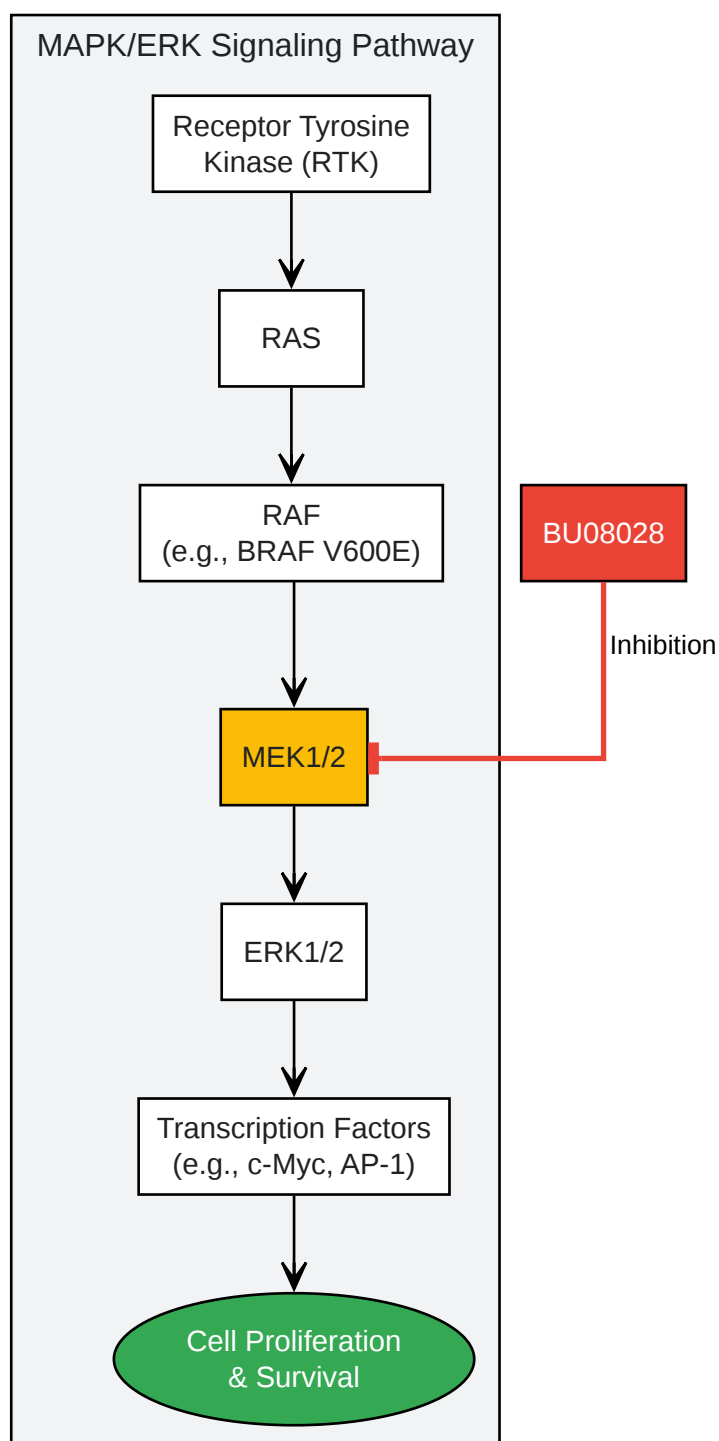

[Click to download full resolution via product page](#)

Caption: Mechanism of action of **BU08028** in the MAPK/ERK signaling pathway.

Dosage Optimization Workflow

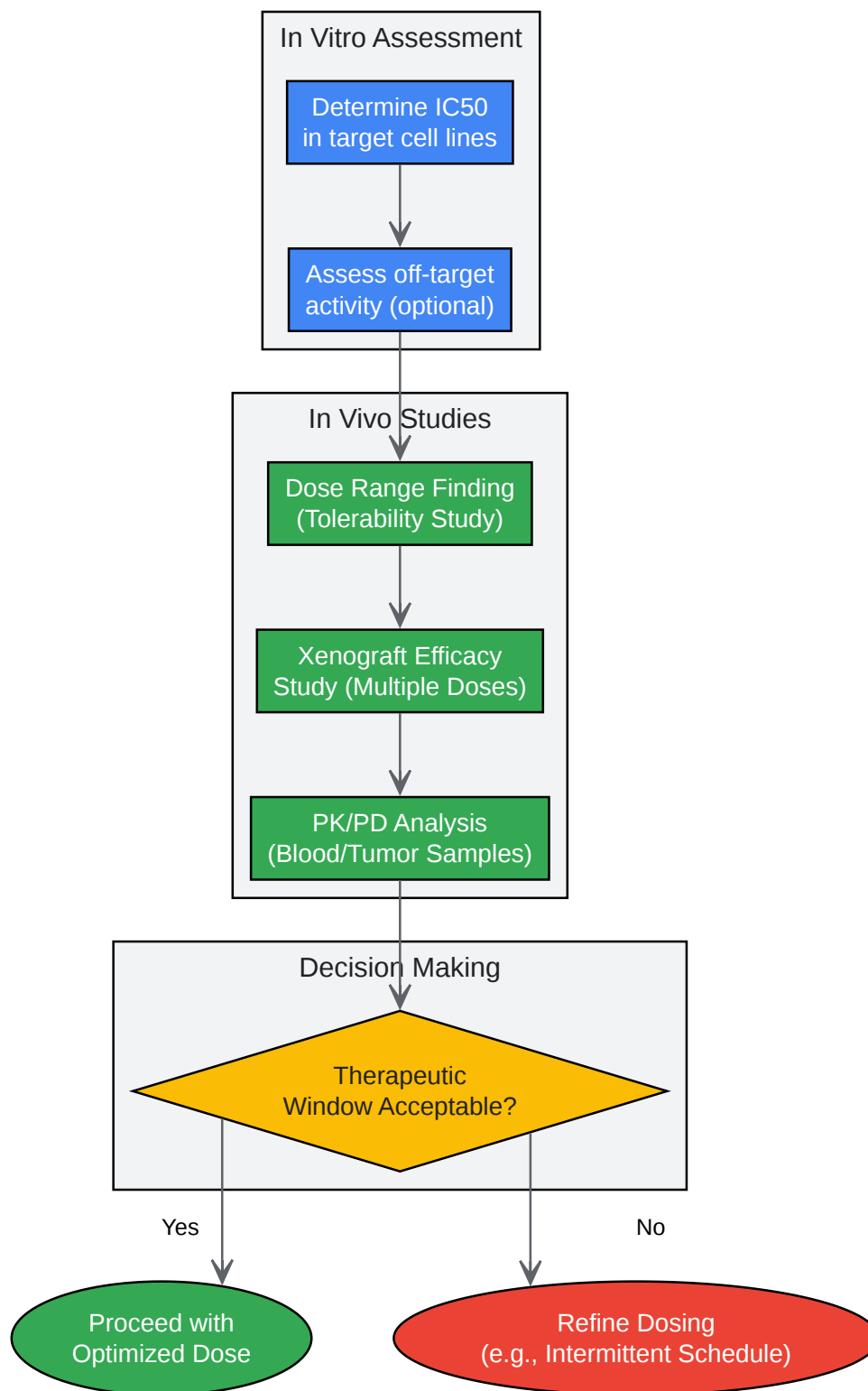

[Click to download full resolution via product page](#)

Caption: Experimental workflow for optimizing **BU08028** dosage.

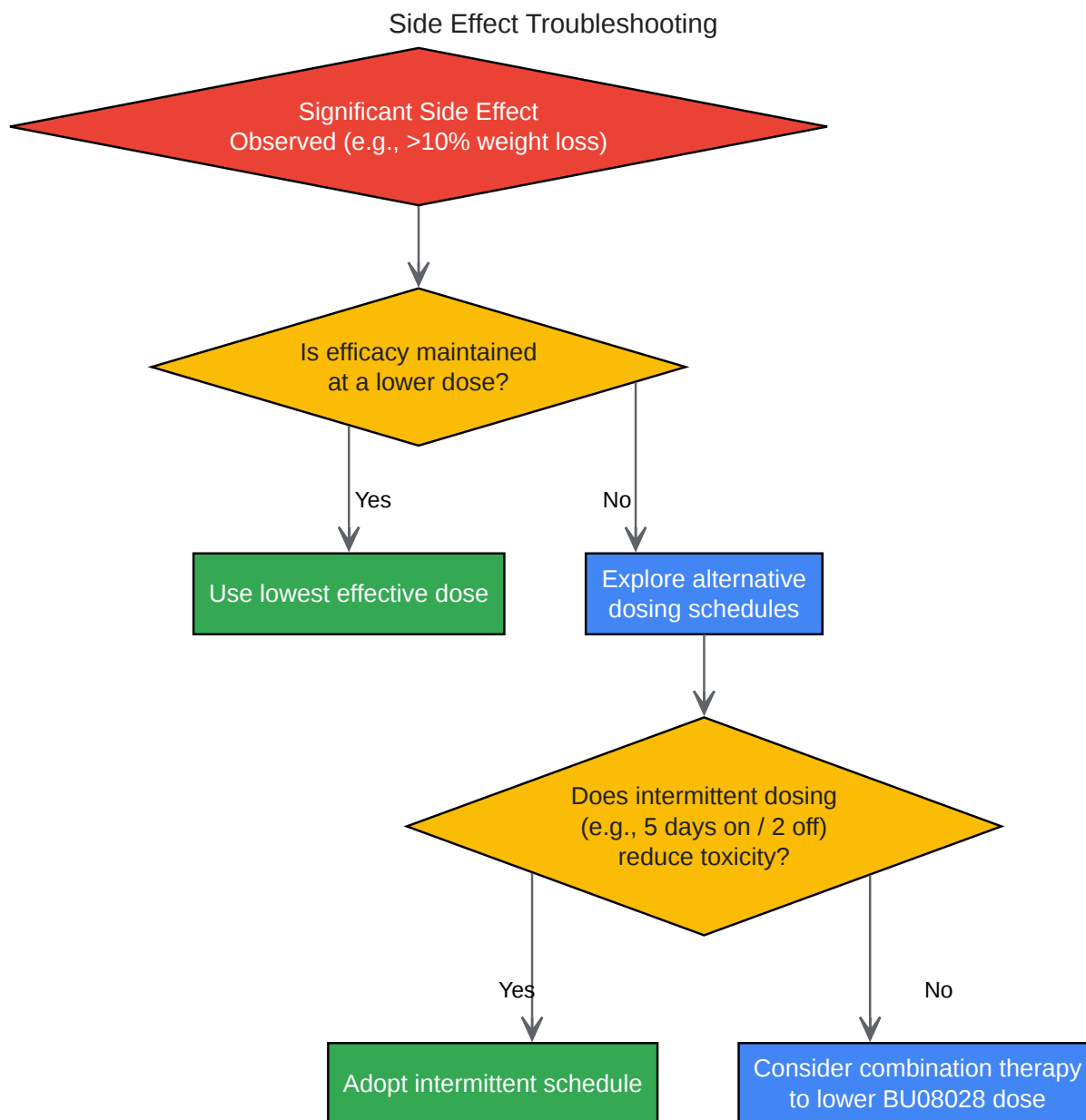

[Click to download full resolution via product page](#)

Caption: Decision tree for troubleshooting common in vivo side effects.

- To cite this document: BenchChem. [Optimizing BU08028 dosage to minimize side effects]. BenchChem, [2026]. [Online PDF]. Available at: [<https://www.benchchem.com/product/b606422/docs#optimizing-bu08028-dosage-to-minimize-side-effects>]

Disclaimer & Data Validity:

The information provided in this document is for Research Use Only (RUO) and is strictly not intended for diagnostic or therapeutic procedures. While BenchChem strives to provide accurate protocols, we make no warranties, express or implied, regarding the fitness of this product for every specific experimental setup.

Technical Support: The protocols provided are for reference purposes. Unsure if this reagent suits your experiment?

Need Industrial/Bulk Grade? [Request Custom Synthesis Quote](#)

BenchChem

Our mission is to be the trusted global source of essential and advanced chemicals, empowering scientists and researchers to drive progress in science and industry.

Contact

Address: 3281 E Guasti Rd
Ontario, CA 91761, United States
Phone: (601) 213-4426
Email: info@benchchem.com

[Contact our Ph.D. Support Team for a compatibility check](#)