

Comparative Efficacy Analysis: BG48 vs. Competitor Compound X in Oncology

Author: BenchChem Technical Support Team. **Date:** April 2026

Compound of Interest

Compound Name: BG48
CAS No.: 1628784-53-1
Cat. No.: B606055

[Get Quote](#)

This guide provides a detailed comparison of the efficacy and underlying mechanisms of two leading immuno-oncology agents: **BG48** and Competitor Compound X. Both compounds are monoclonal antibodies that target the programmed cell death-1 (PD-1) receptor, a critical immune checkpoint.^{[1][2]} By blocking the PD-1 pathway, these therapies are designed to restore the immune system's ability to recognize and eliminate cancer cells.^{[3][4][5]} This document is intended for researchers, scientists, and drug development professionals, offering an objective analysis supported by clinical trial data and detailed experimental protocols.

Mechanism of Action: Targeting the PD-1/PD-L1 Signaling Pathway

BG48 and Competitor Compound X share a common mechanism of action: the blockade of the interaction between the PD-1 receptor on T-cells and its ligands, PD-L1 and PD-L2.^{[5][6]} Tumor cells often overexpress PD-L1 on their surface, which engages with the PD-1 receptor on activated T-cells.^{[3][7]} This interaction transmits an inhibitory signal that deactivates the T-cell, allowing the tumor to evade immune surveillance.^{[4][8]} Both **BG48** and Competitor Compound X bind with high affinity to the PD-1 receptor, sterically hindering the binding of PD-L1 and PD-

L2.[6] This action effectively "releases the brakes" on the T-cell, restoring its cytotoxic functions against the tumor.[2]

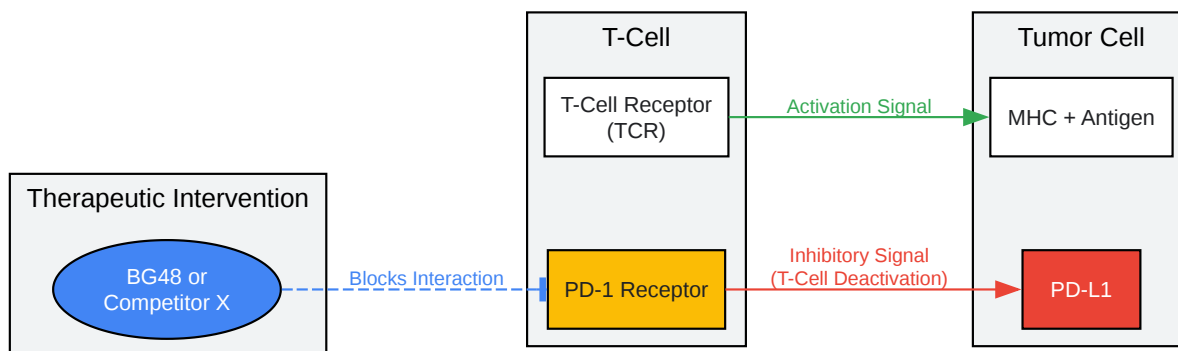

[Click to download full resolution via product page](#)

Caption: PD-1/PD-L1 signaling pathway and therapeutic blockade.

Comparative Efficacy in Previously Treated Non-Small Cell Lung Cancer (NSCLC)

To provide a quantitative comparison, this guide summarizes data from pivotal Phase III clinical trials for **BG48** (based on the KEYNOTE-010 trial) and Competitor Compound X (based on a pooled analysis of CheckMate 017 & 057 trials) in patients with previously treated, advanced NSCLC.

Efficacy Endpoint	BG48 (Pembrolizumab) - KEYNOTE-010	Competitor Compound X (Nivolumab) - CheckMate 017 & 057 (Pooled)	Control Arm (Docetaxel)
Patient Population	Previously treated NSCLC (PD-L1 TPS $\geq 1\%$)[9]	Previously treated NSCLC (Squamous & Non-Squamous)[10]	Previously treated NSCLC[9][10]
Median Overall Survival (OS)	10.4 months (2 mg/kg dose)[11]	12.2 months	8.5 - 9.4 months[10][11]
5-Year Overall Survival Rate	Not explicitly stated in initial reports.	13.4%[10]	2.6%[10]
Median Progression-Free Survival (PFS)	3.9 months (2 mg/kg dose)[11]	2.9 months	4.0 - 4.2 months[10][11]
Objective Response Rate (ORR)	18% (2 mg/kg dose)[12]	19%	9 - 12%[12][13]
Treatment-Related Adverse Events (Grade 3-5)	13% (2 mg/kg dose)[11]	10%	35 - 55%[11][13]

Note: Data is compiled from separate trials and should not be interpreted as a direct head-to-head comparison. Efficacy can vary based on PD-L1 expression levels and patient histology.

Experimental Protocols

The data presented is derived from robust, randomized, open-label, international Phase III studies. The general methodologies are outlined below.

BG48 (based on KEYNOTE-010 Protocol)[9][11]

- Study Design: A randomized, open-label, phase 2/3 trial.[9]
- Patient Population: Patients with advanced NSCLC with disease progression after platinum-based chemotherapy. A key inclusion criterion was PD-L1 expression on at least 1% of tumor

cells (Tumor Proportion Score [TPS] $\geq 1\%$).[\[9\]](#)[\[14\]](#)

- Randomization: Patients were randomly assigned in a 1:1:1 ratio.
- Treatment Arms:
 - **BG48** at 2 mg/kg intravenously every 3 weeks.[\[11\]](#)
 - **BG48** at 10 mg/kg intravenously every 3 weeks.[\[11\]](#)
 - Docetaxel (chemotherapy) at 75 mg/m² intravenously every 3 weeks.[\[11\]](#)
- Primary Endpoints: Overall Survival (OS) and Progression-Free Survival (PFS), analyzed in both the total population (TPS $\geq 1\%$) and in a cohort with high PD-L1 expression (TPS $\geq 50\%$).[\[9\]](#)
- Tumor Assessment: Performed every 9 weeks according to RECIST v1.1 criteria.[\[14\]](#)

Competitor Compound X (based on CheckMate 017 & 057 Protocols)[\[10\]](#)[\[15\]](#)

- Study Design: Two separate randomized, open-label, phase III trials (017 for squamous NSCLC, 057 for non-squamous NSCLC).[\[10\]](#)
- Patient Population: Patients with advanced or metastatic NSCLC who had progressed during or after one prior platinum-based doublet chemotherapy regimen.[\[10\]](#)[\[13\]](#)
- Randomization: Patients were randomly assigned in a 1:1 ratio.
- Treatment Arms:
 - Competitor Compound X at 3 mg/kg intravenously every 2 weeks.[\[10\]](#)
 - Docetaxel (chemotherapy) at 75 mg/m² intravenously every 3 weeks.[\[10\]](#)
- Primary Endpoint: Overall Survival (OS).[\[10\]](#)

- Tumor Assessment: Performed at 9 weeks, then every 6 weeks for the first year, and every 12 weeks thereafter, according to RECIST v1.1.[10]

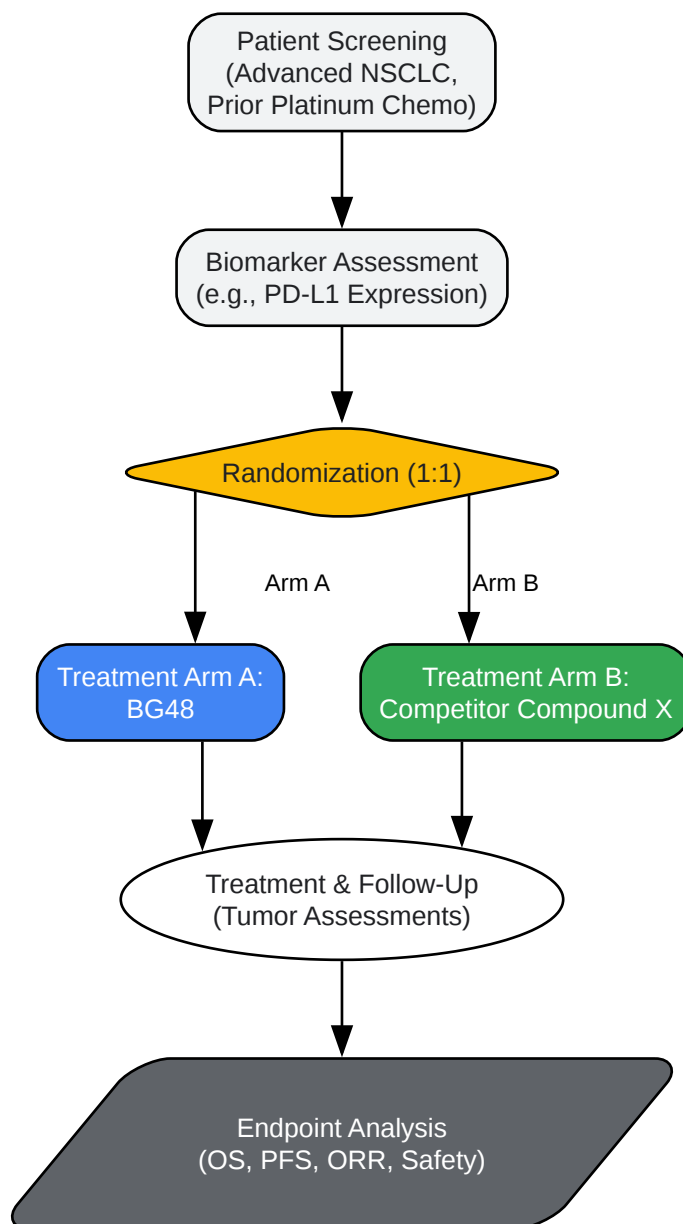

[Click to download full resolution via product page](#)

Caption: A generalized workflow for a comparative clinical trial.

Need Custom Synthesis?

BenchChem offers custom synthesis for rare earth carbides and specific isotopic labeling.

Email: info@benchchem.com or [Request Quote Online](#).

References

- 1. Pembrolizumab vs. nivolumab: How do they compare? [drugs.com]
- 2. Molecular Farming of Pembrolizumab and Nivolumab - PMC [pmc.ncbi.nlm.nih.gov]
- 3. Cancer immunotherapy and the PD-1/PD-L1 checkpoint pathway | Abcam [abcam.com]
- 4. Roles of PD-1/PD-L1 Pathway: Signaling, Cancer, and Beyond - PubMed [pubmed.ncbi.nlm.nih.gov]
- 5. What is the mechanism of action of Pembrolizumab? [synapse.patsnap.com]
- 6. A molecular and preclinical comparison of the PD-1–targeted T-cell checkpoint inhibitors nivolumab and pembrolizumab - PMC [pmc.ncbi.nlm.nih.gov]
- 7. creative-diagnostics.com [creative-diagnostics.com]
- 8. PD-1/PD-L1 Signaling Pathway and Tumor Immune Escape [scirp.org]
- 9. ctg.queensu.ca [ctg.queensu.ca]
- 10. Five-Year Outcomes From the Randomized, Phase III Trials CheckMate 017 and 057: Nivolumab Versus Docetaxel in Previously Treated Non–Small-Cell Lung Cancer - PMC [pmc.ncbi.nlm.nih.gov]
- 11. Pembrolizumab versus docetaxel for previously treated, PD-L1-positive, advanced non-small-cell lung cancer (KEYNOTE-010): a randomised controlled trial - PubMed [pubmed.ncbi.nlm.nih.gov]
- 12. clinician.nejm.org [clinician.nejm.org]
- 13. ascopubs.org [ascopubs.org]
- 14. keytrudahcp.com [keytrudahcp.com]
- To cite this document: BenchChem. [Comparative Efficacy Analysis: BG48 vs. Competitor Compound X in Oncology]. BenchChem, [2026]. [Online PDF]. Available at: [https://www.benchchem.com/product/b606055/docs#comparative-efficacy-analysis-bg48-vs-competitor-compound-x-in-oncology]

Disclaimer & Data Validity:

The information provided in this document is for Research Use Only (RUO) and is strictly not intended for diagnostic or therapeutic procedures. While BenchChem strives to provide accurate protocols, we make no warranties, express or implied, regarding the fitness of this product for every specific experimental setup.

Technical Support: The protocols provided are for reference purposes. Unsure if this reagent suits your experiment?

Need Industrial/Bulk Grade? [Request Custom Synthesis Quote](#)

BenchChem

Our mission is to be the trusted global source of essential and advanced chemicals, empowering scientists and researchers to drive progress in science and industry.

Contact

Address: 3281 E Guasti Rd
Ontario, CA 91761, United States
Phone: (601) 213-4426
Email: info@benchchem.com

[Contact our Ph.D. Support Team for a compatibility check](#)