

# BMS-202 Off-Target Binding Profile: A Technical Support Resource

**Author:** BenchChem Technical Support Team. **Date:** April 2026

## Compound of Interest

Compound Name:	Bms-202
CAS No.:	1675203-84-5
Cat. No.:	B606222

[Get Quote](#)

This technical support center provides researchers, scientists, and drug development professionals with troubleshooting guides and frequently asked questions regarding the off-target binding profile of **BMS-202**. All quantitative data is summarized for clarity, and detailed experimental protocols are provided for key assays.

## Frequently Asked Questions (FAQs)

Q1: What is the primary mechanism of action of **BMS-202**?

A1: **BMS-202** is a small molecule inhibitor of the Programmed Death-1/Programmed Death-Ligand 1 (PD-1/PD-L1) interaction. It binds directly to PD-L1, inducing its homodimerization. This prevents PD-L1 from binding to the PD-1 receptor on T-cells, thereby blocking the inhibitory signal and restoring T-cell anti-tumor activity.<sup>[1]</sup>

Q2: Have any comprehensive off-target screening panels (e.g., kinome scans) for **BMS-202** been published?

A2: As of the latest available data, no comprehensive, broad-panel off-target screening data (such as a full kinome scan or a safety panel against a wide range of receptors and ion

channels) for **BMS-202** has been publicly released.

Q3: Are there any known or suspected off-target effects of **BMS-202**?

A3: Yes, several studies have reported direct cytotoxic effects of **BMS-202** on cancer cells, which appear to be independent of its PD-L1 checkpoint inhibition.[2][3] This suggests the presence of off-target activities. One study has specifically implicated an effect on mitochondrial function in melanoma cells.[4][5][6] Additionally, effects on ERK and TGFβ1/Smad signaling have been observed in fibroblasts.[7]

Q4: What is the evidence for the direct cytotoxic effects of **BMS-202**?

A4: In vivo studies using humanized MHC-double knockout NOG mice showed a clear anti-tumor effect of **BMS-202**. However, this was not accompanied by lymphocyte accumulation at the tumor site, suggesting a direct cytotoxic mechanism is involved in the anti-tumor effect.[2] In vitro studies have also demonstrated that **BMS-202** can inhibit the proliferation of various cancer cell lines.[1][8]

Q5: How might **BMS-202** be affecting mitochondrial function?

A5: Research in A375 melanoma cells has shown that **BMS-202** can localize in mitochondria.[4][5][6] The study reported that **BMS-202** treatment led to increased expression of mitochondrial respiratory chain complexes I and IV, enhanced ATP production, and the promotion of apoptosis.[4][5] This suggests that a potential off-target effect of **BMS-202** involves the modulation of mitochondrial activity.

## Troubleshooting Guides

This section addresses specific issues that researchers might encounter during their experiments with **BMS-202**.

### Issue 1: Discrepancy between PD-1/PD-L1 Inhibition and Cellular Potency

- Problem: The IC50 value for PD-1/PD-L1 binding inhibition in a biochemical assay (e.g., HTRF) is significantly lower than the IC50 for cytotoxicity in a cell-based assay.

- Possible Cause: This is a common observation and is likely due to the contribution of off-target effects to the cellular phenotype. The potent on-target binding (in the nanomolar range) may not be the sole driver of cell death, which occurs at higher (micromolar) concentrations.<sup>[1][8][9]</sup>
- Troubleshooting Steps:
  - Confirm On-Target Engagement: Use a cellular thermal shift assay (CETSA) to verify that **BMS-202** is engaging with PD-L1 in your cell line at the expected concentrations.
  - Investigate Off-Target Cytotoxicity: Perform a dose-response cytotoxicity assay (e.g., MTT or CellTiter-Glo) in a PD-L1 negative cell line. If cytotoxicity is still observed, it strongly suggests an off-target mechanism.
  - Mitochondrial Function Analysis: Based on published findings, assess mitochondrial health and function in response to **BMS-202** treatment. This can include measuring mitochondrial membrane potential, oxygen consumption rates, or ATP production.
  - Apoptosis Assays: Determine if the observed cytotoxicity is due to apoptosis by using assays such as Annexin V/PI staining followed by flow cytometry, or by measuring caspase activity.

## Issue 2: Unexpected Phenotypes in In Vivo Models

- Problem: In an in vivo study, tumor regression is observed, but there is no significant increase in tumor-infiltrating lymphocytes (TILs) as would be expected from checkpoint blockade.
- Possible Cause: This phenotype was observed in a study with humanized MHC-dKO NOG mice and was attributed to a direct, off-target cytotoxic effect of **BMS-202** on the tumor cells.<sup>[2]</sup>
- Troubleshooting Steps:
  - Immunohistochemistry (IHC) Analysis: Perform IHC on tumor sections to analyze the presence of immune cell markers (e.g., CD3, CD4, CD8) to confirm the lack of immune infiltration.

- Ex Vivo Analysis: Isolate tumor cells from treated and control animals and perform in vitro cytotoxicity assays to confirm a direct effect of the compound.
- Consider the Model: The immune composition of the in vivo model is critical. The effect of **BMS-202** may vary between syngeneic models with a fully competent immune system and immunodeficient or humanized models.

## Quantitative Data Summary

Parameter	Value	Assay	Target/Cell Line
On-Target Affinity			
IC50	18 nM	HTRF	PD-1/PD-L1 Binding
Kd	8 $\mu$ M	-	PD-L1 Binding
Cellular Cytotoxicity			
IC50	15 $\mu$ M	Proliferation Assay	SCC-3 cells
IC50	10 $\mu$ M	Proliferation Assay	Jurkat cells

## Experimental Protocols

### Homogeneous Time-Resolved Fluorescence (HTRF) for PD-1/PD-L1 Binding

- Principle: This assay measures the proximity of biotinylated PD-L1 and Europium-labeled PD-1. When in close proximity, excitation of the Europium donor results in energy transfer to the Streptavidin-XL665 acceptor bound to biotinylated PD-L1, generating a FRET signal.
- Methodology:
  - Prepare a solution of biotinylated human PD-L1 protein.
  - Prepare a solution of Europium cryptate-labeled human PD-1 protein.
  - In a 384-well plate, add **BMS-202** at various concentrations.
  - Add the PD-L1 and PD-1 solutions to the wells.

- Add Streptavidin-XL665.
- Incubate the plate at room temperature for 1-2 hours, protected from light.
- Read the plate on an HTRF-compatible reader, measuring the emission at 665 nm and 620 nm.
- The ratio of the two wavelengths is calculated, and IC50 values are determined from the dose-response curve.

## MTT Assay for Cell Viability

- Principle: This colorimetric assay measures the reduction of yellow tetrazolium salt (MTT) to purple formazan crystals by mitochondrial dehydrogenases in viable cells. The amount of formazan produced is proportional to the number of living cells.
- Methodology:
  - Seed cells in a 96-well plate and allow them to adhere overnight.
  - Treat the cells with various concentrations of **BMS-202** for the desired duration (e.g., 24, 48, 72 hours).
  - Add MTT solution (typically 5 mg/mL in PBS) to each well and incubate for 2-4 hours at 37°C.
  - Remove the medium and add a solubilizing agent (e.g., DMSO or a specialized solubilization buffer) to dissolve the formazan crystals.
  - Measure the absorbance at a wavelength between 540 and 590 nm using a microplate reader.
  - Calculate cell viability as a percentage of the untreated control.

## Cellular Thermal Shift Assay (CETSA) for Target Engagement

- Principle: Ligand binding stabilizes a target protein, leading to an increase in its melting temperature. CETSA measures the amount of soluble protein remaining after heating cells to various temperatures.
- Methodology:
  - Treat cultured cells with **BMS-202** or a vehicle control for a defined period.
  - Harvest the cells and resuspend them in a suitable buffer.
  - Aliquot the cell suspension into PCR tubes and heat them to a range of temperatures for a short duration (e.g., 3 minutes).
  - Cool the samples and lyse the cells (e.g., by freeze-thaw cycles).
  - Centrifuge the lysates at high speed to pellet precipitated proteins.
  - Collect the supernatant containing the soluble protein fraction.
  - Analyze the amount of the target protein (PD-L1) in the soluble fraction by Western blot or another protein detection method.
  - Plot the amount of soluble protein as a function of temperature to generate a melting curve. A shift in the curve upon drug treatment indicates target engagement.

## Visualizations

PD-1/PD-L1 Signaling Pathway

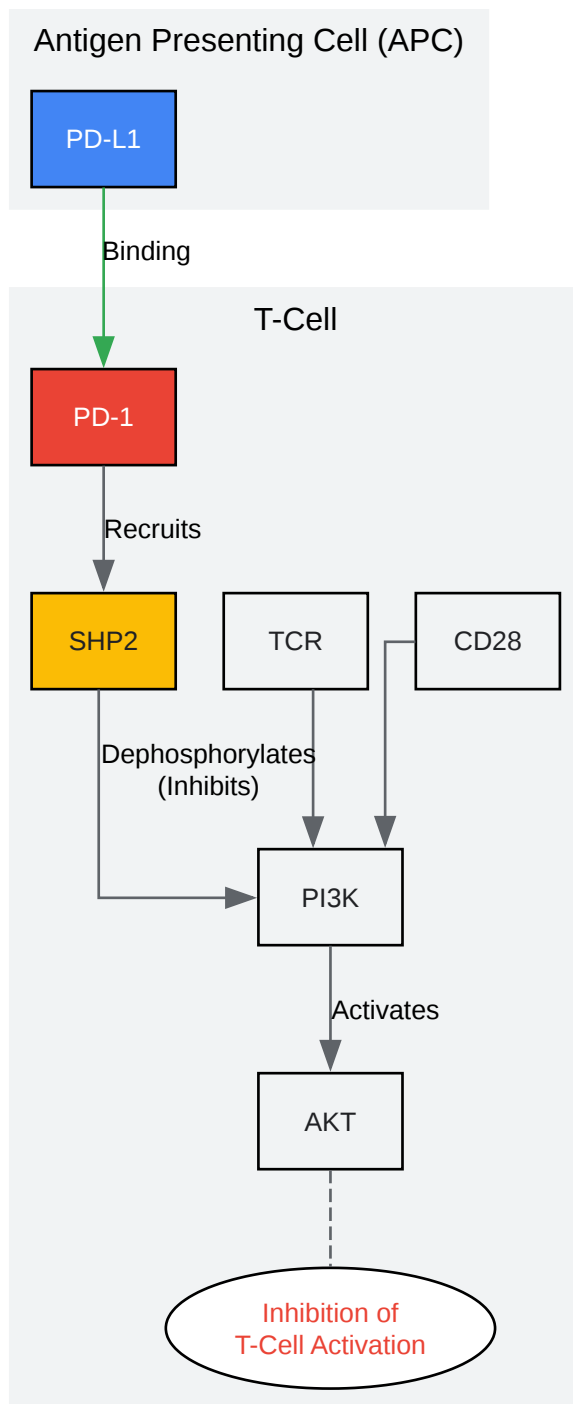

[Click to download full resolution via product page](#)

Caption: PD-1/PD-L1 signaling pathway leading to T-cell inhibition.

## Proposed Off-Target Mechanism of BMS-202

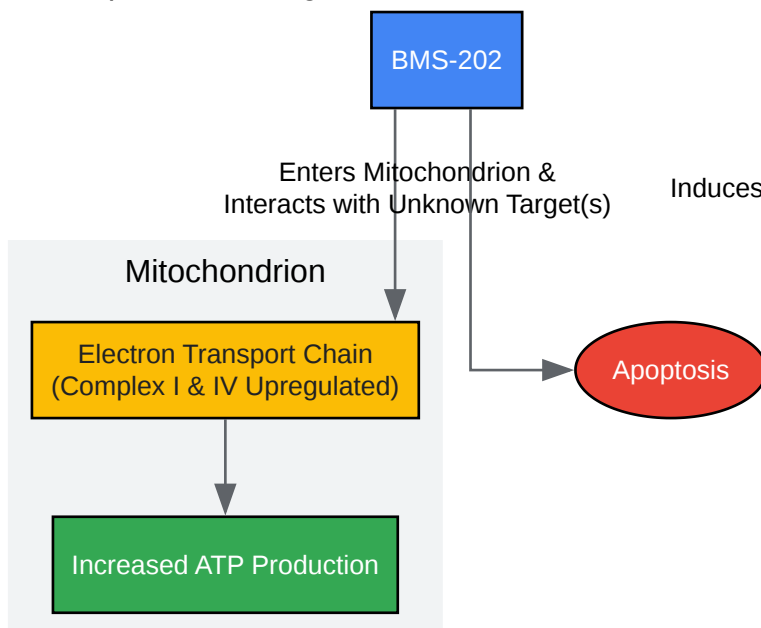

[Click to download full resolution via product page](#)

Caption: Proposed mitochondrial-mediated off-target cytotoxicity of **BMS-202**.

## Workflow for Investigating Off-Target Effects

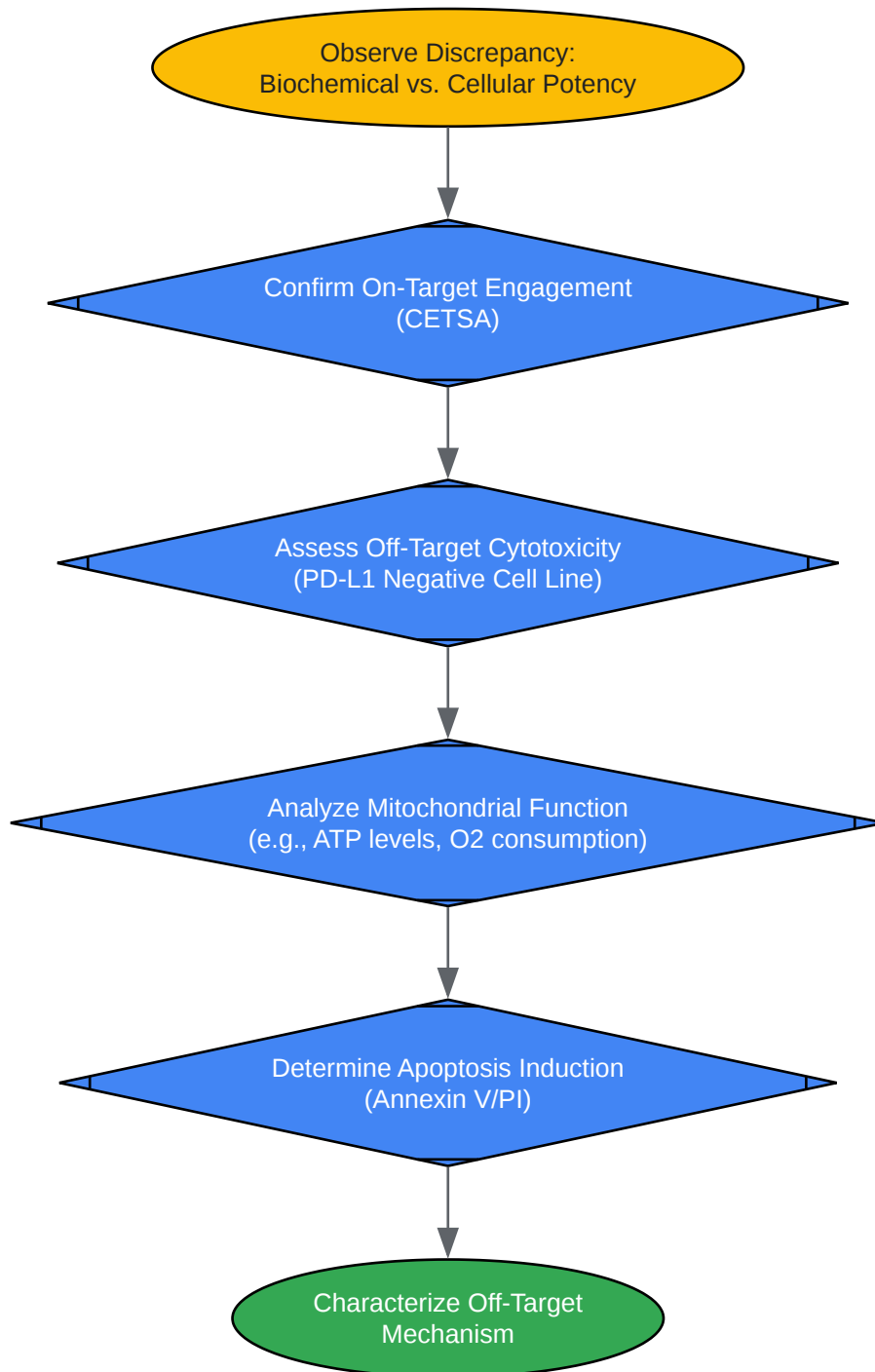

[Click to download full resolution via product page](#)

Caption: A logical workflow for the experimental investigation of **BMS-202** off-target effects.

### Need Custom Synthesis?

BenchChem offers custom synthesis for rare earth carbides and specific isotopic labeling.

Email: [info@benchchem.com](mailto:info@benchchem.com) or [Request Quote Online](#).

## References

- [1. medchemexpress.com \[medchemexpress.com\]](https://www.medchemexpress.com)
- [2. Antitumor activity of the PD-1/PD-L1 binding inhibitor BMS-202 in the humanized MHC-double knockout NOG mouse \[jstage.jst.go.jp\]](https://www.jstage.jst.go.jp)
- [3. researchgate.net \[researchgate.net\]](https://www.researchgate.net)
- [4. Direct effects of the small molecule PD-L1 inhibitor BMS-202 on A375 melanoma cells: Anti-tumor activity accompanied by increased mitochondrial function - PMC \[pmc.ncbi.nlm.nih.gov\]](https://pubmed.ncbi.nlm.nih.gov)
- [5. Direct effects of the small molecule PD-L1 inhibitor BMS-202 on A375 melanoma cells: Anti-tumor activity accompanied by increased mitochondrial function - PubMed \[pubmed.ncbi.nlm.nih.gov\]](https://pubmed.ncbi.nlm.nih.gov)
- [6. researchgate.net \[researchgate.net\]](https://www.researchgate.net)
- [7. BMS-202, a PD-1/PD-L1 inhibitor, decelerates the pro-fibrotic effects of fibroblasts derived from scar tissues via ERK and TGF \$\beta\$ 1/Smad signaling pathways - PMC \[pmc.ncbi.nlm.nih.gov\]](https://pubmed.ncbi.nlm.nih.gov)
- [8. selleckchem.com \[selleckchem.com\]](https://www.selleckchem.com)
- [9. Discovery of Novel Small-Molecule Inhibitors of PD-1/PD-L1 Interaction via Structural Simplification Strategy \[mdpi.com\]](https://www.mdpi.com)
- To cite this document: BenchChem. [BMS-202 Off-Target Binding Profile: A Technical Support Resource]. BenchChem, [2026]. [Online PDF]. Available at: [\[https://www.benchchem.com/product/b606222/docs#bms-202-off-target-binding-profile-a-technical-support-resource\]](https://www.benchchem.com/product/b606222/docs#bms-202-off-target-binding-profile-a-technical-support-resource)

---

### Disclaimer & Data Validity:

The information provided in this document is for Research Use Only (RUO) and is strictly not intended for diagnostic or therapeutic procedures. While BenchChem strives to provide

accurate protocols, we make no warranties, express or implied, regarding the fitness of this product for every specific experimental setup.

**Technical Support:** The protocols provided are for reference purposes. Unsure if this reagent suits your experiment?

**Need Industrial/Bulk Grade?** [Request Custom Synthesis Quote](#)

## BenchChem

Our mission is to be the trusted global source of essential and advanced chemicals, empowering scientists and researchers to drive progress in science and industry.

### Contact

Address: 3281 E Guasti Rd

Ontario, CA 91761, United States

Phone: (601) 213-4426

Email: [info@benchchem.com](mailto:info@benchchem.com)

[Contact our Ph.D. Support Team for a compatibility check](#)