

# Application Notes and Protocols for Compound X (formerly BzDANP)

**Author:** BenchChem Technical Support Team. **Date:** April 2026

## Compound of Interest

Compound Name: BzDANP

Cat. No.: B606438

[Get Quote](#)

For Research Use Only. Not for use in diagnostic procedures.

## Introduction

Compound X is a novel synthetic small molecule demonstrating potent anti-proliferative and pro-apoptotic activity in various cancer cell lines. These application notes provide an overview of Compound X's mechanism of action and detailed protocols for its use in cell culture experiments. The information is intended for researchers, scientists, and drug development professionals investigating novel anti-cancer therapeutics.

## Mechanism of Action

Compound X is an inhibitor of the PI3K/Akt signaling pathway, a critical pathway for cell survival and proliferation. By inhibiting this pathway, Compound X induces cell cycle arrest and apoptosis in cancer cells.

## Quantitative Data Summary

The following tables summarize the quantitative data obtained from in-vitro studies of Compound X on various cancer cell lines.

Table 1: IC50 Values of Compound X in Cancer Cell Lines

Cell Line	Cancer Type	IC50 ( $\mu\text{M}$ ) after 72h treatment
MCF-7	Breast Cancer	5.2
MDA-MB-231	Breast Cancer	8.1
A549	Lung Cancer	12.5
HCT116	Colon Cancer	6.8
HeLa	Cervical Cancer	15.3

Table 2: Apoptosis Induction by Compound X

Cell Line	Treatment Concentration ( $\mu\text{M}$ )	Incubation Time (h)	% Apoptotic Cells (Annexin V positive)
MCF-7	10	48	45.2%
HCT116	10	48	38.9%

## Experimental Protocols

### Cell Viability Assay (MTT Assay)

This protocol determines the concentration of Compound X that inhibits cell viability by 50% (IC50).

Materials:

- Cancer cell lines of interest
- Complete growth medium (e.g., DMEM with 10% FBS)
- Compound X stock solution (e.g., 10 mM in DMSO)

- 96-well plates
- MTT (3-(4,5-dimethylthiazol-2-yl)-2,5-diphenyltetrazolium bromide) solution (5 mg/mL in PBS)
- DMSO
- Multichannel pipette
- Plate reader (570 nm)

#### Procedure:

- Cell Seeding:
  - Trypsinize and count the cells.
  - Seed 5,000 cells per well in 100  $\mu$ L of complete growth medium in a 96-well plate.
  - Incubate for 24 hours at 37°C, 5% CO<sub>2</sub>.
- Compound X Treatment:
  - Prepare serial dilutions of Compound X in complete growth medium.
  - Remove the old medium from the wells and add 100  $\mu$ L of the diluted Compound X solutions. Include a vehicle control (DMSO) and a no-treatment control.
  - Incubate for 72 hours at 37°C, 5% CO<sub>2</sub>.
- MTT Assay:
  - Add 20  $\mu$ L of MTT solution to each well.
  - Incubate for 4 hours at 37°C.
  - Carefully remove the medium.
  - Add 150  $\mu$ L of DMSO to each well to dissolve the formazan crystals.

- Read the absorbance at 570 nm using a plate reader.
- Data Analysis:
  - Calculate the percentage of cell viability for each concentration relative to the vehicle control.
  - Plot the cell viability against the log concentration of Compound X to determine the IC50 value.

## Apoptosis Assay (Annexin V-FITC/PI Staining)

This protocol quantifies the percentage of apoptotic cells after treatment with Compound X.

Materials:

- Cancer cell lines
- Complete growth medium
- Compound X stock solution
- 6-well plates
- Annexin V-FITC Apoptosis Detection Kit
- Flow cytometer

Procedure:

- Cell Seeding and Treatment:
  - Seed  $2 \times 10^5$  cells per well in 2 mL of complete growth medium in a 6-well plate.
  - Incubate for 24 hours.
  - Treat the cells with the desired concentration of Compound X (e.g., 10  $\mu$ M) and a vehicle control.

- Incubate for 48 hours.
- Cell Harvesting and Staining:
  - Collect both adherent and floating cells.
  - Wash the cells with cold PBS.
  - Resuspend the cells in 1X Binding Buffer at a concentration of  $1 \times 10^6$  cells/mL.
  - Transfer 100  $\mu$ L of the cell suspension to a new tube.
  - Add 5  $\mu$ L of Annexin V-FITC and 5  $\mu$ L of Propidium Iodide (PI).
  - Gently vortex and incubate for 15 minutes at room temperature in the dark.
  - Add 400  $\mu$ L of 1X Binding Buffer to each tube.
- Flow Cytometry Analysis:
  - Analyze the samples by flow cytometry within 1 hour.
  - Annexin V-FITC positive, PI negative cells are in early apoptosis.
  - Annexin V-FITC positive, PI positive cells are in late apoptosis or necrosis.

## Visualizations

### Signaling Pathway of Compound X

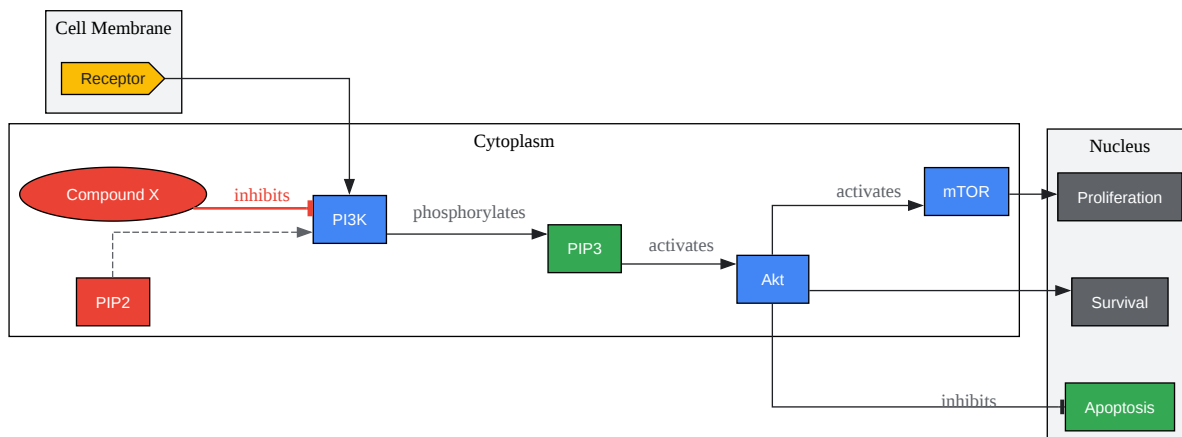

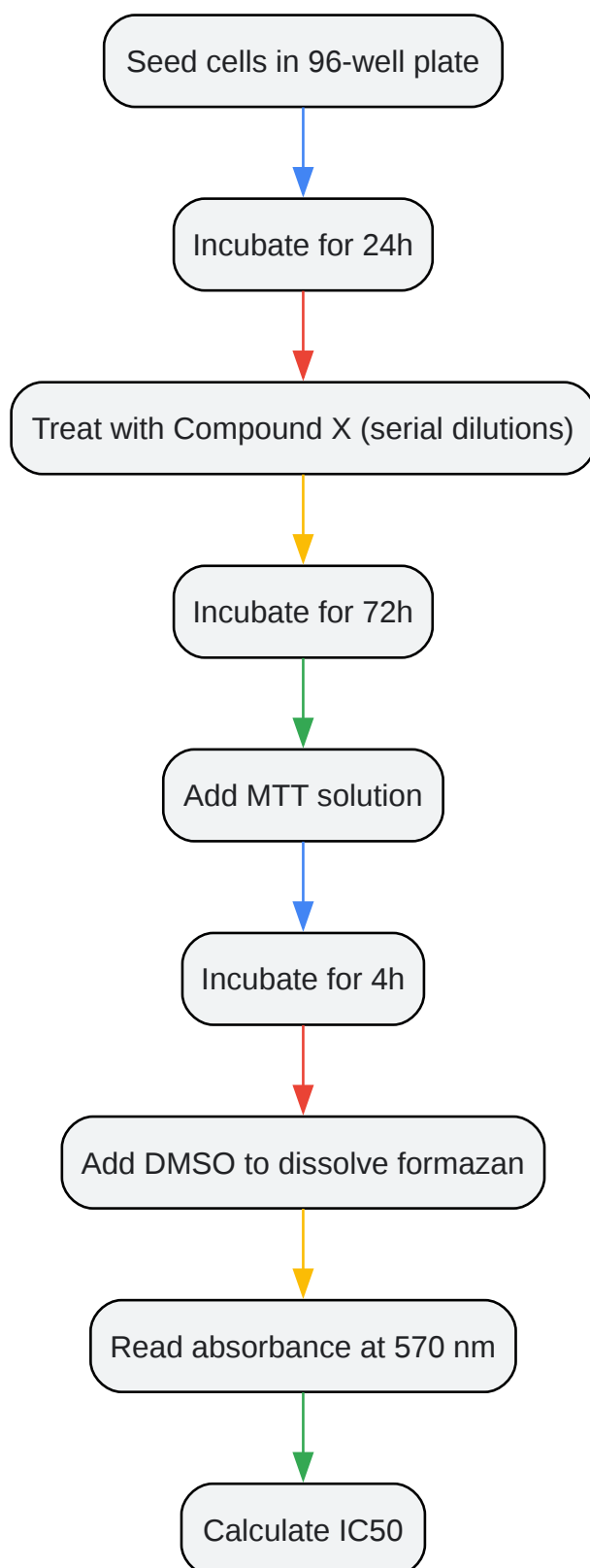

[Click to download full resolution via product page](#)

- To cite this document: BenchChem. [Application Notes and Protocols for Compound X (formerly BzDANP)]. BenchChem, [2026]. [Online PDF]. Available at: [<https://www.benchchem.com/product/b606438/docs#application-notes-and-protocols-for-compound-x-formerly-bzdanp>]

---

### Disclaimer & Data Validity:

The information provided in this document is for Research Use Only (RUO) and is strictly not intended for diagnostic or therapeutic procedures. While BenchChem strives to provide accurate protocols, we make no warranties, express or implied, regarding the fitness of this product for every specific experimental setup.

**Technical Support:** The protocols provided are for reference purposes. Unsure if this reagent suits your experiment?

**Need Industrial/Bulk Grade?** [Request Custom Synthesis Quote](#)

## BenchChem

Our mission is to be the trusted global source of essential and advanced chemicals, empowering scientists and researchers to drive progress in science and industry.

### Contact

Address: 3281 E Guasti Rd  
Ontario, CA 91761, United States  
Phone: (601) 213-4426  
Email: [info@benchchem.com](mailto:info@benchchem.com)

[Contact our Ph.D. Support Team for a compatibility check](#)