

Application Notes and Protocols for BMS-986142 in Murine Arthritis Models

Author: BenchChem Technical Support Team. **Date:** April 2026

Compound of Interest

Compound Name:	BMS-986142
CAS No.:	1643368-58-4
Cat. No.:	B606288

[Get Quote](#)

For Researchers, Scientists, and Drug Development Professionals

These application notes provide a comprehensive overview of the administration and efficacy of **BMS-986142**, a potent and highly selective reversible Bruton's tyrosine kinase (BTK) inhibitor, in preclinical mouse models of rheumatoid arthritis.[1][2][3][4] The provided protocols and data are intended to guide researchers in designing and executing studies to evaluate BTK inhibitors in similar models.

Mechanism of Action

BMS-986142 exerts its therapeutic effects by inhibiting BTK, a critical enzyme in the signaling pathways of various immune cells implicated in the pathophysiology of rheumatoid arthritis.[2][3] Specifically, **BMS-986142** has been shown to block:

- B-Cell Receptor (BCR) Signaling: Inhibition of BCR signaling in B cells reduces the production of autoantibodies and inflammatory cytokines, such as IL-6 and TNF- α . [3]
- Fc γ Receptor (Fc γ R) Signaling: In myeloid cells, **BMS-986142** inhibits Fc γ R-mediated cytokine production, a key process in inflammatory responses. [1][3]

- RANK-L-Induced Osteoclastogenesis: The compound blocks the differentiation of monocytic precursors into osteoclasts, thereby protecting against bone resorption and erosion characteristic of arthritic joints.[2][3]

BMS-986142 is a highly selective inhibitor, demonstrating potent activity against BTK with an IC50 of 0.5 nM, while showing significantly less activity against other kinases.[1][4]

Signaling Pathway Overview

The following diagram illustrates the key signaling pathways modulated by **BMS-986142** in the context of arthritis.

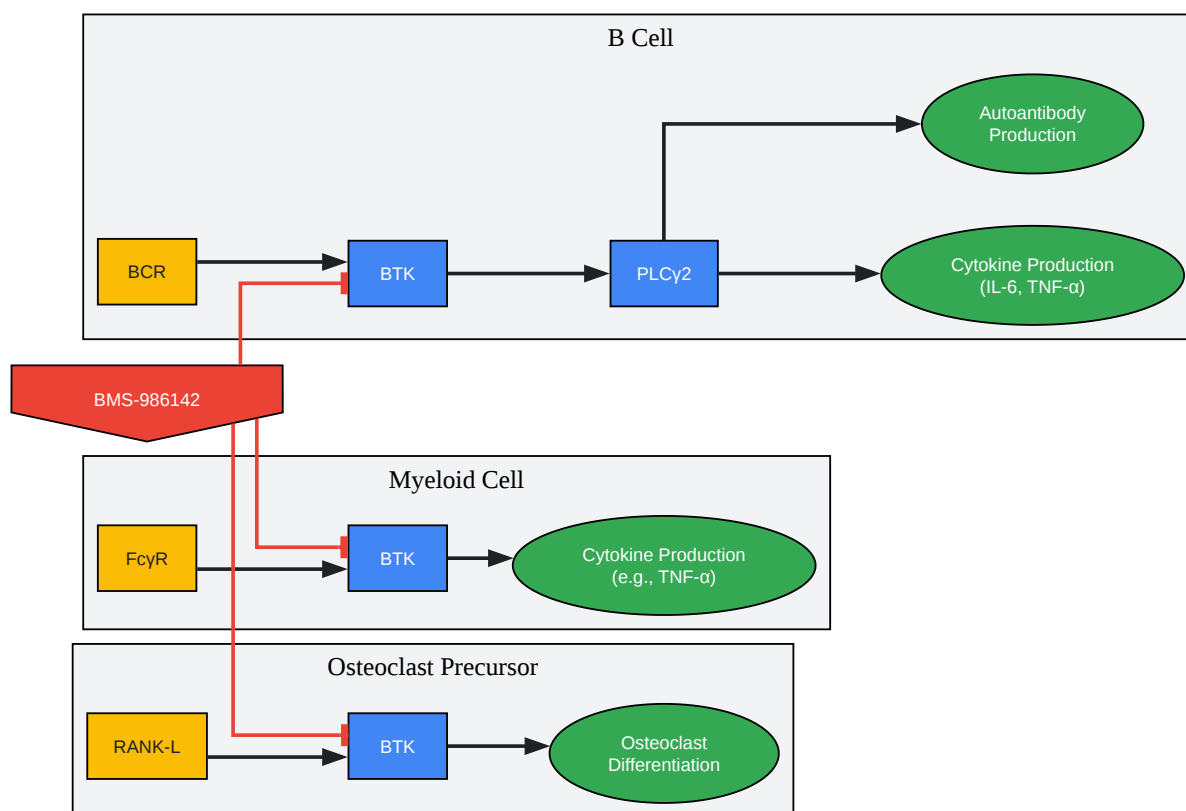

[Click to download full resolution via product page](#)

Caption: **BMS-986142** inhibits BTK in B cells, myeloid cells, and osteoclast precursors.

Efficacy Data in Murine Arthritis Models

BMS-986142 has demonstrated significant efficacy in reducing disease severity in both Collagen-Induced Arthritis (CIA) and Collagen Antibody-Induced Arthritis (CAIA) mouse models.

[\[1\]](#)[\[2\]](#)[\[3\]](#)

Table 1: Efficacy of **BMS-986142** Monotherapy in the CAIA Model

Treatment Group (Dose, p.o., q.d.)	Mean Clinical Score Reduction vs. Vehicle	Reference
BMS-986142 (5 mg/kg)	72%	[1] [3]
BMS-986142 (20 mg/kg)	>90% (Essentially complete protection)	[1] [3]

Table 2: Efficacy of **BMS-986142** Monotherapy in the CIA Model (Preventative Dosing)

Treatment Group (Dose, p.o., q.d.)	Clinical Score Reduction vs. Vehicle at Study End	Reference
BMS-986142 (4 mg/kg)	26%	[4]
BMS-986142 (10 mg/kg)	43%	[4]
BMS-986142 (30 mg/kg)	79%	[4]

Table 3: Efficacy of **BMS-986142** Monotherapy in the CIA Model (Therapeutic Dosing)

Treatment Group (Dose, p.o., q.d.)	Clinical Score Reduction vs. Vehicle at Study End	Reference
BMS-986142 (2 mg/kg)	17%	[1][3][4]
BMS-986142 (4 mg/kg)	37%	[1][3][4]
BMS-986142 (25 mg/kg)	67%	[1][3][4]

Table 4: Efficacy of BMS-986142 Combination Therapy in the CIA Model

Treatment Group	Clinical Score Inhibition	Reduction in Inflammation & Bone Resorption	Reference
Methotrexate (MTX) alone (0.25 mg/kg)	19%	10%	[4]
BMS-986142 alone (4 mg/kg)	-	24%	[3]
BMS-986142 (4 mg/kg) + MTX (0.25 mg/kg)	54% (additive benefit)	53%	[4]

Experimental Protocols

Detailed methodologies for inducing and treating arthritis in mouse models are provided below.

Protocol 1: Collagen-Induced Arthritis (CIA) Mouse Model

This model is T-cell and B-cell dependent and is widely used to study the pathogenesis of rheumatoid arthritis.[5][6]

Materials:

- Male DBA/1 mice (8–10 weeks old)[3]

- Bovine Type II Collagen
- Complete Freund's Adjuvant (CFA) or Sigma Adjuvant System[3]
- **BMS-986142**
- Vehicle: 5% Ethanol, 5% Tocopherol PEG 1000 Succinate (TPGS), 90% PEG300[3][4]

Procedure:

- Immunization (Day 0): Prepare an emulsion of bovine type II collagen (200 µg per mouse) with an equal volume of CFA or Sigma Adjuvant System.[3]
- Administer a 0.1 mL subcutaneous injection at the base of the tail.[3][5]
- Booster Immunization (Day 21): Administer a second subcutaneous injection with the same collagen emulsion.[3]
- Drug Administration:
 - Preventative Regimen: Begin daily oral gavage (p.o., q.d.) of **BMS-986142** or vehicle immediately after the first immunization (Day 0) and continue throughout the study.[3][4]
 - Therapeutic Regimen: Delay the start of daily oral gavage until the booster immunization on Day 21.[3][4]
- Monitoring: Monitor mice three times per week for the development and severity of paw inflammation. Clinical scores are typically assigned based on the degree of erythema and swelling.[3]
- Endpoint Analysis: At the end of the study, collect blood for pharmacokinetic analysis and serum for anti-collagen antibody titers.[3] Hind paws can be collected for histological evaluation of inflammation, synovial hyperplasia, bone resorption, and cartilage erosion.[1]

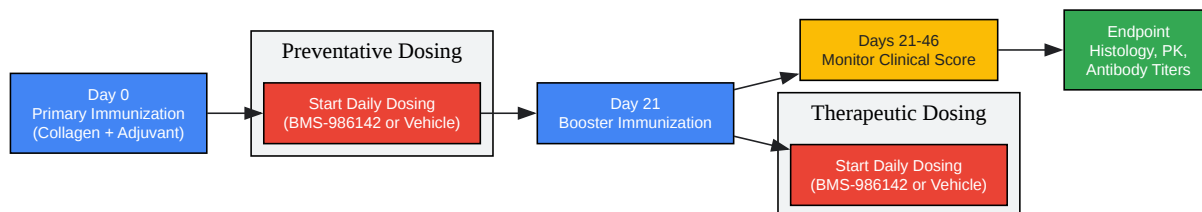

[Click to download full resolution via product page](#)

Caption: Experimental workflow for the Collagen-Induced Arthritis (CIA) model.

Protocol 2: Collagen Antibody-Induced Arthritis (CAIA) Mouse Model

The CAIA model is dependent on FcγR-driven mechanisms but is independent of B and T cells. It offers a more rapid and synchronized onset of arthritis.[1][3][7]

Materials:

- Female BALB/c mice (8–10 weeks old)[3]
- Mixture of 4 monoclonal anti-mouse type II collagen antibodies[3]
- Lipopolysaccharide (LPS) from E. coli O111:B4[3]
- **BMS-986142**
- Vehicle: 5% EtOH, 5% TPGS, 90% PEG300[3]

Procedure:

- Antibody Administration (Day 0): Administer a cocktail of anti-mouse type II collagen antibodies (total of 4 mg) intraperitoneally (IP) to each mouse.[3]
- Drug Administration: Immediately begin prophylactic daily oral gavage (p.o., q.d.) with **BMS-986142** or vehicle.[3]

- LPS Boost (Day 3): Administer an IP injection of LPS (1.25 mg/kg) to synchronize and enhance the inflammatory response.[3]
- Monitoring: Monitor mice daily for the development and severity of paw inflammation using a clinical scoring system.[3]
- Endpoint Analysis (Day 12): At study termination, collect hind paws for histological evaluation of inflammation, bone resorption, and cartilage erosion.[1]

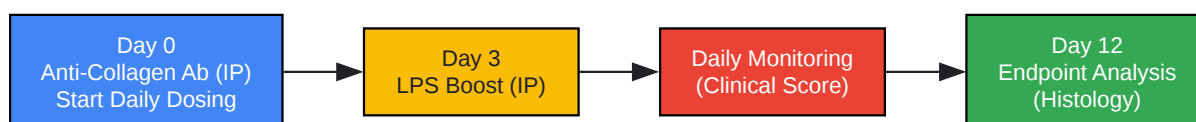

[Click to download full resolution via product page](#)

Need Custom Synthesis?

BenchChem offers custom synthesis for rare earth carbides and specific isotopic labeling.

Email: info@benchchem.com or [Request Quote Online](#).

References

1. Bruton's tyrosine kinase inhibitor BMS-986142 in experimental models of rheumatoid arthritis enhances efficacy of agents representing clinical standard-of-care | PLOS One [journals.plos.org]
2. Bruton's tyrosine kinase inhibitor BMS-986142 in experimental models of rheumatoid arthritis enhances efficacy of agents representing clinical standard-of-care - PubMed [pubmed.ncbi.nlm.nih.gov]
3. Bruton's tyrosine kinase inhibitor BMS-986142 in experimental models of rheumatoid arthritis enhances efficacy of agents representing clinical standard-of-care - PMC [pmc.ncbi.nlm.nih.gov]
4. medchemexpress.com [medchemexpress.com]
5. chondrex.com [chondrex.com]
6. resources.amsbio.com [resources.amsbio.com]

- 7. Standardized protocol and outcome measurements for the collagen antibody-induced arthritis mouse model - PMC [[pmc.ncbi.nlm.nih.gov](https://pubmed.ncbi.nlm.nih.gov/)]
- To cite this document: BenchChem. [Application Notes and Protocols for BMS-986142 in Murine Arthritis Models]. BenchChem, [2026]. [Online PDF]. Available at: [<https://www.benchchem.com/product/b606288/docs#application-notes-and-protocols-for-bms-986142-in-murine-arthritis-models>]

Disclaimer & Data Validity:

The information provided in this document is for Research Use Only (RUO) and is strictly not intended for diagnostic or therapeutic procedures. While BenchChem strives to provide accurate protocols, we make no warranties, express or implied, regarding the fitness of this product for every specific experimental setup.

Technical Support: The protocols provided are for reference purposes. Unsure if this reagent suits your experiment?

Need Industrial/Bulk Grade? [Request Custom Synthesis Quote](#)

BenchChem

Our mission is to be the trusted global source of essential and advanced chemicals, empowering scientists and researchers to drive progress in science and industry.

Contact

Address: 3281 E Guasti Rd
Ontario, CA 91761, United States
Phone: (601) 213-4426
Email: info@benchchem.com

[Contact our Ph.D. Support Team for a compatibility check](#)