

Technical Support Center: AZD-3289 Long-Term Studies

Author: BenchChem Technical Support Team. **Date:** April 2026

Compound of Interest

Compound Name: AZD-3289

Cat. No.: B605755

[Get Quote](#)

Disclaimer: **AZD-3289** is a BACE1 inhibitor. Currently, there is limited publicly available data specifically on the long-term toxicity profile of **AZD-3289**. The following troubleshooting guides and FAQs are based on the known class effects of BACE1 inhibitors observed in preclinical and clinical studies of other molecules in this class. Researchers should interpret this information as a general guide and establish a robust safety monitoring plan for their specific long-term studies with **AZD-3289**.

Frequently Asked Questions (FAQs)

Q1: What is the primary mechanism of action of **AZD-3289** and how does it relate to potential toxicities?

A1: **AZD-3289** is a potent inhibitor of the β -site amyloid precursor protein cleaving enzyme 1 (BACE1). BACE1 is the rate-limiting enzyme in the production of amyloid- β (A β) peptides, which are central to the amyloid cascade hypothesis of Alzheimer's disease.[1] By inhibiting BACE1, **AZD-3289** aims to reduce the formation of A β plaques in the brain.[2]

However, BACE1 has several other physiological substrates besides the amyloid precursor protein (APP).[1][3] These substrates are involved in various biological processes, including

myelination, synaptic function, and cell signaling.[4][5] Therefore, long-term inhibition of BACE1 by **AZD-3289** could potentially interfere with these processes, leading to on-target toxicities.

Q2: What are the most common adverse events observed with BACE1 inhibitors in long-term clinical trials?

A2: Several BACE1 inhibitors have been evaluated in long-term clinical trials. While the specific adverse event profiles can vary between compounds, some common toxicities have been reported across the class. These include:

- **Cognitive Worsening:** Paradoxically, some BACE1 inhibitors have been associated with a decline in cognitive function in clinical trials.[6][7] This is thought to be a mechanism-based effect due to the inhibition of BACE1's role in processing substrates essential for synaptic plasticity.[6][8]
- **Hepatic Effects:** Liver toxicity, including elevated liver enzymes, has been a significant concern with some BACE1 inhibitors, leading to the termination of clinical trials.[9][10]
- **Neurological and Psychiatric Effects:** Adverse events such as anxiety, insomnia, vivid dreams, and dizziness have been reported.[7][11]
- **Dermatological Effects:** Rashes and changes in hair color have been observed, which may be related to the inhibition of BACE2, a closely related protease.[11]
- **General Effects:** Other reported side effects include falls and weight loss.[11]

Q3: Are there strategies to minimize the potential for cognitive worsening with **AZD-3289**?

A3: Minimizing cognitive side effects is a critical challenge in the long-term administration of BACE1 inhibitors. The current thinking is that the degree of BACE1 inhibition is a key factor.[12] While high levels of inhibition are effective at reducing $A\beta$, they are more likely to cause adverse cognitive effects.[8][12]

Troubleshooting Strategies:

- **Dose-Response Analysis:** The primary strategy is to identify a therapeutic window by conducting a thorough dose-response study. The goal is to find the lowest effective dose of

AZD-3289 that provides a significant reduction in A β without causing detectable cognitive or synaptic deficits.[8]

- **Assess Target Engagement and Substrate Cleavage:** It is crucial to not rely solely on A β levels as a biomarker. Measuring the cleavage of other key BACE1 substrates, such as neuregulin-1 (NRG1) or seizure-related protein 6 (SEZ6), can provide a more comprehensive picture of BACE1 inhibition.[8] If these physiological substrates are heavily inhibited, it may indicate a higher risk of side effects.[8]

Troubleshooting Guides

Guide 1: Investigating Unexpected Cognitive Decline in Animal Models

Problem: Animals treated with **AZD-3289** in a long-term study are showing impaired performance in cognitive tasks (e.g., Morris water maze, contextual fear conditioning) compared to the vehicle control group.

Possible Causes and Troubleshooting Steps:

- **Excessive BACE1 Inhibition:** The dose of **AZD-3289** may be too high, leading to the inhibition of BACE1's function on substrates critical for synaptic plasticity.
 - **Action:** Perform a dose-ranging study to identify a lower dose that still achieves a target level of A β reduction (e.g., 30-50%) while minimizing cognitive impairment.[8][12]
- **Off-Target Effects:** Although **AZD-3289** is designed to be a specific BACE1 inhibitor, off-target activities cannot be completely ruled out.
 - **Action:** Conduct in vitro profiling of **AZD-3289** against a panel of other proteases and receptors to assess its selectivity.
- **Compound-Specific Toxicity:** The observed cognitive effects might be specific to the chemical properties of **AZD-3289**, independent of BACE1 inhibition.
 - **Action:** Compare the cognitive effects of **AZD-3289** with other BACE1 inhibitors with different chemical scaffolds, if available.

Guide 2: Monitoring for Potential Liver Toxicity

Problem: How to proactively monitor for and troubleshoot potential liver toxicity during long-term studies with **AZD-3289**.

Monitoring and Troubleshooting Plan:

- Regular Blood Chemistry Monitoring:
 - Action: Collect blood samples at regular intervals (e.g., monthly) and analyze liver function markers, including Alanine Aminotransferase (ALT), Aspartate Aminotransferase (AST), and Bilirubin.
- Histopathological Examination:
 - Action: At the end of the study, or if significant elevations in liver enzymes are observed, perform a thorough histopathological examination of liver tissue from treated and control animals.
- Investigate Mechanism of Toxicity:
 - Action: If liver toxicity is confirmed, consider further studies to determine if it is an on-target effect (related to BACE1 inhibition in the liver) or an off-target, compound-specific effect. This could involve measuring the levels of BACE1 substrates in the liver.[\[10\]](#)

Data Presentation

Table 1: Summary of Selected Adverse Events Reported in Clinical Trials of BACE1 Inhibitors

Adverse Event	Verubecestat[1]	Atabecestat[13]	Lanabecestat[6]	LY2886721[9][10]
Cognitive Worsening	Reported	Reported	Reported	Not a primary reason for termination
Elevated Liver Enzymes	Not a primary concern	Yes, led to trial termination	Not a primary reason for termination	Yes, led to trial termination
Anxiety	Reported	-	-	-
Insomnia/Sleep Disturbances	Reported	-	-	-
Rashes	More common than placebo	-	-	-
Hair Color Changes	Frequent	-	-	-
Weight Loss	Reported	-	-	-
Falls	Reported	-	-	-

Note: This table is a summary of publicly available information and may not be exhaustive. "-" indicates that this adverse event was not a prominent reported reason for trial discontinuation or a frequently cited side effect in the provided search results.

Experimental Protocols

Protocol 1: Western Blot Analysis of BACE1 Substrate Cleavage

Objective: To quantify the effect of **AZD-3289** on the cleavage of a non-APP BACE1 substrate (e.g., SEZ6) in brain tissue. An increase in the full-length protein or a decrease in its shed ectodomain indicates target engagement.[8]

Methodology:

- Tissue Homogenization: Homogenize brain tissue (e.g., hippocampus or cortex) in ice-cold RIPA buffer supplemented with protease and phosphatase inhibitors.[8]
- Protein Quantification: Determine the total protein concentration of the lysates using a BCA assay.
- SDS-PAGE: Separate equal amounts of protein from each sample on a polyacrylamide gel. Include a molecular weight marker.
- Electrophoretic Transfer: Transfer the separated proteins to a PVDF membrane.[8]
- Blocking: Block the membrane for 1 hour at room temperature in 5% non-fat milk or BSA in Tris-buffered saline with 0.1% Tween 20 (TBST).[8]
- Primary Antibody Incubation: Incubate the membrane overnight at 4°C with a primary antibody specific for the full-length or C-terminal fragment of SEZ6. Use a loading control antibody (e.g., β -actin or GAPDH) on the same membrane.[8]
- Washing: Wash the membrane 3 times for 10 minutes each with TBST.[8]
- Secondary Antibody Incubation: Incubate with an appropriate HRP-conjugated secondary antibody for 1 hour at room temperature.[8]
- Detection: Detect the signal using an enhanced chemiluminescence (ECL) substrate and image the blot using a digital imager.[8]
- Analysis: Quantify the band intensities using software like ImageJ. Normalize the intensity of the target protein band to the loading control. Compare the levels between **AZD-3289**-treated and vehicle control groups.[8]

Mandatory Visualization

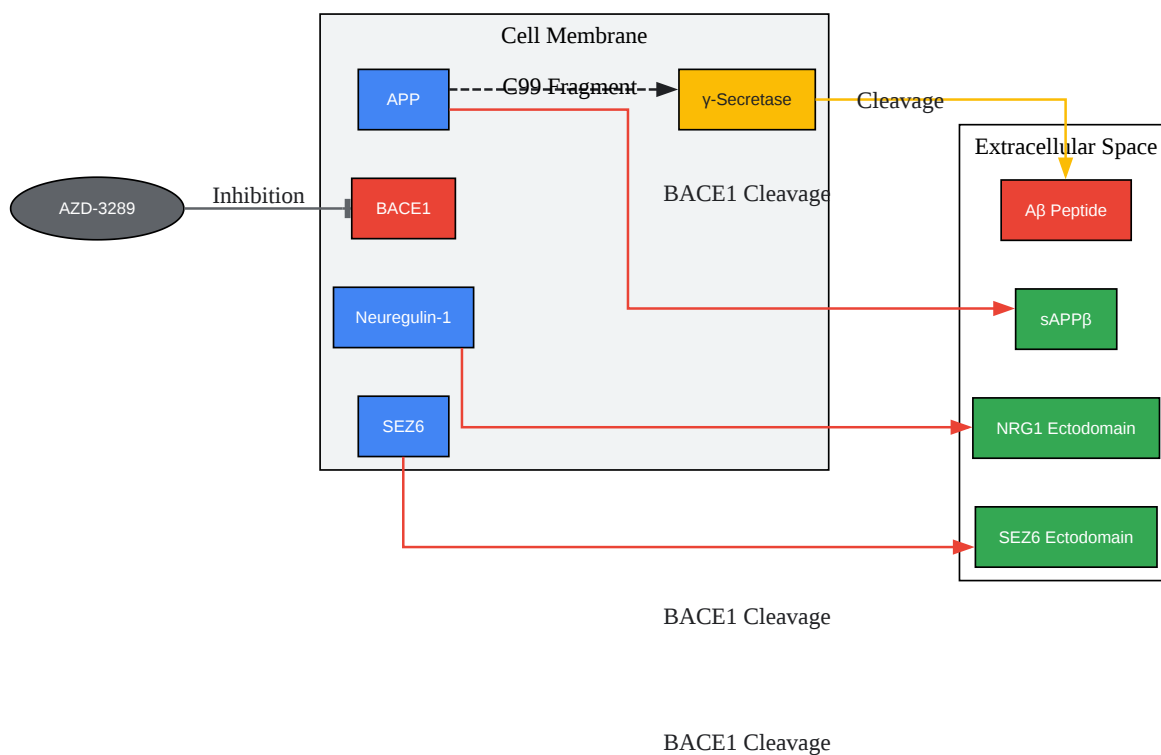

[Click to download full resolution via product page](#)

Caption: BACE1 signaling pathway and the inhibitory action of **AZD-3289**.

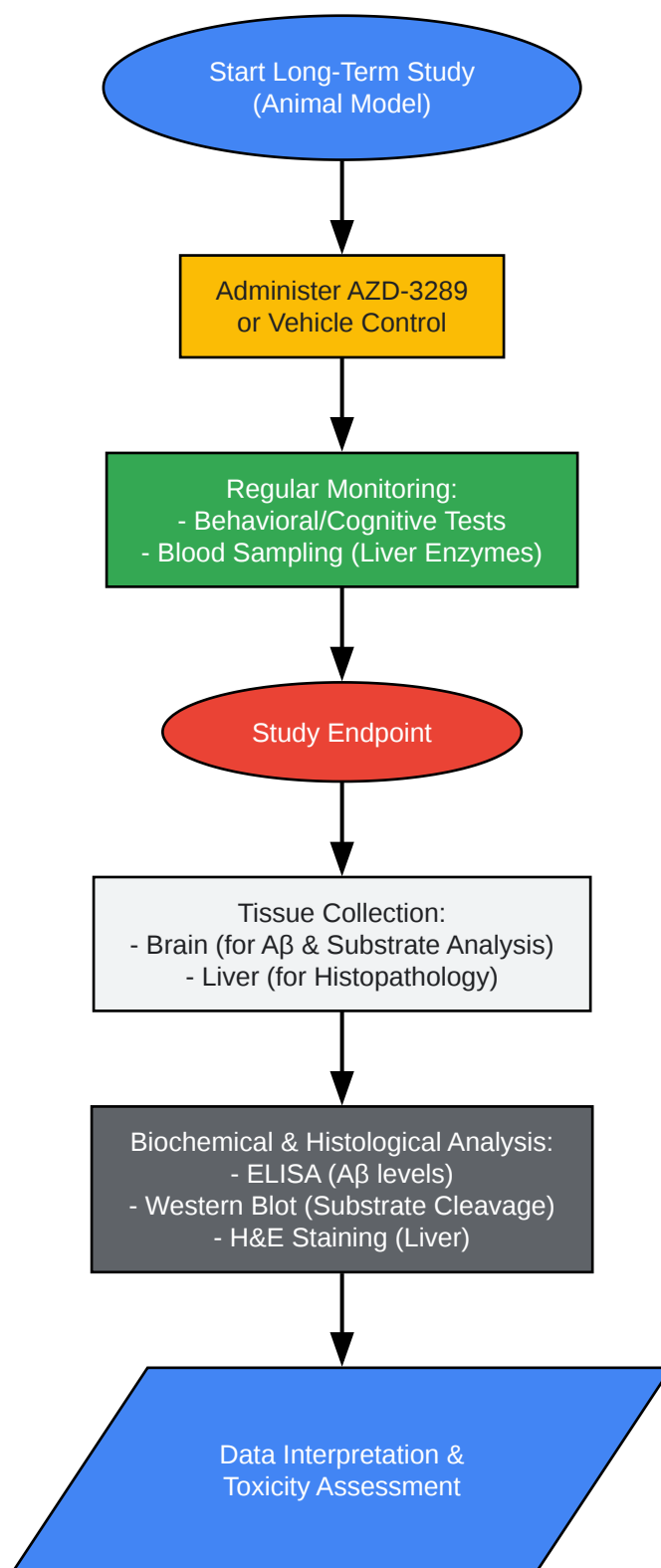

[Click to download full resolution via product page](#)

Caption: Experimental workflow for assessing **AZD-3289** toxicity in long-term studies.

Need Custom Synthesis?

BenchChem offers custom synthesis for rare earth carbides and specific isotopic labeling.

Email: info@benchchem.com or [Request Quote Online](#).

References

- 1. Identification of β -Secretase (BACE1) Substrates Using Quantitative Proteomics - PMC [[pmc.ncbi.nlm.nih.gov](https://pubmed.ncbi.nlm.nih.gov)]
- 2. conservancy.umn.edu [conservancy.umn.edu]
- 3. Identification of beta-secretase (BACE1) substrates using quantitative proteomics - PubMed [pubmed.ncbi.nlm.nih.gov]
- 4. Secretome protein enrichment identifies physiological BACE1 protease substrates in neurons | The EMBO Journal [link.springer.com]
- 5. Alzheimer's Drug Could Cause Adverse Side Effects - News Center [news.feinberg.northwestern.edu]
- 6. Adverse Neurologic Effect of BACE1 inhibitors in Alzheimer's disease trials - PMC [[pmc.ncbi.nlm.nih.gov](https://pubmed.ncbi.nlm.nih.gov)]
- 7. Exploring the cognitive impact of BACE1 inhibition for Alzheimer's disease | VJDemencia [vjdementia.com]
- 8. benchchem.com [benchchem.com]
- 9. BACE1 Inhibitors for Alzheimer's Disease: The Past, Present and Any Future? - PMC [[pmc.ncbi.nlm.nih.gov](https://pubmed.ncbi.nlm.nih.gov)]
- 10. Lessons from a BACE inhibitor trial: Off-site but not off base - PMC [[pmc.ncbi.nlm.nih.gov](https://pubmed.ncbi.nlm.nih.gov)]
- 11. A Close Look at BACE1 Inhibitors for Alzheimer's Disease Treatment - PMC [[pmc.ncbi.nlm.nih.gov](https://pubmed.ncbi.nlm.nih.gov)]
- 12. alzheimersnewstoday.com [alzheimersnewstoday.com]
- 13. BACE1: A Key Regulator in Alzheimer's Disease Progression and Current Development of its Inhibitors - PMC [[pmc.ncbi.nlm.nih.gov](https://pubmed.ncbi.nlm.nih.gov)]
- To cite this document: BenchChem. [Technical Support Center: AZD-3289 Long-Term Studies]. BenchChem, [2026]. [Online PDF]. Available at:

[<https://www.benchchem.com/product/b605755/docs#technical-support-center-azd-3289-long-term-studies>]

Disclaimer & Data Validity:

The information provided in this document is for Research Use Only (RUO) and is strictly not intended for diagnostic or therapeutic procedures. While BenchChem strives to provide accurate protocols, we make no warranties, express or implied, regarding the fitness of this product for every specific experimental setup.

Technical Support: The protocols provided are for reference purposes. Unsure if this reagent suits your experiment?

Need Industrial/Bulk Grade? [Request Custom Synthesis Quote](#)

BenchChem

Our mission is to be the trusted global source of essential and advanced chemicals, empowering scientists and researchers to drive progress in science and industry.

Contact

Address: 3281 E Guasti Rd
Ontario, CA 91761, United States
Phone: (601) 213-4426
Email: info@benchchem.com

[Contact our Ph.D. Support Team for a compatibility check](#)