

Application Notes and Protocols for the Quantification of AR-V7 mRNA

Author: BenchChem Technical Support Team. **Date:** April 2026

Compound of Interest

Compound Name:	AR7
CAS No.:	80306-38-3
Cat. No.:	B605561

[Get Quote](#)

Audience: Researchers, scientists, and drug development professionals.

Introduction: The androgen receptor (AR) is a critical driver of prostate cancer. Therapies targeting the AR ligand-binding domain (LBD), such as enzalutamide and abiraterone, are standard treatments for metastatic castration-resistant prostate cancer (CRPC). However, resistance to these therapies frequently develops. One of the key mechanisms of resistance is the expression of constitutively active AR splice variants (AR-Vs) that lack the LBD.[1][2]

The most well-characterized of these variants is Androgen Receptor Splice Variant 7 (AR-V7). AR-V7 mRNA is formed by a splicing event that connects exon 3 to a cryptic exon within intron 3 (CE3), resulting in a truncated but constitutively active protein that can drive tumor progression in the absence of androgens.[3] The detection and quantification of AR-V7 mRNA in patient samples, such as circulating tumor cells (CTCs) and tissue biopsies, has emerged as a critical biomarker for predicting resistance to AR-targeted therapies and guiding treatment decisions.[3][4]

This document provides detailed application notes and protocols for the most common methods used to quantify AR-V7 mRNA levels: Reverse Transcription Quantitative PCR (RT-

qPCR), Droplet Digital PCR (ddPCR), and RNA Sequencing (RNA-Seq).

AR-V7 Signaling Pathway

The full-length androgen receptor (AR-FL) is activated by binding to androgens like dihydrotestosterone (DHT), leading to its dimerization, nuclear translocation, and the transcription of target genes that promote cell growth and survival. AR-V7 lacks the ligand-binding domain targeted by drugs like enzalutamide. This allows it to translocate to the nucleus and activate gene expression constitutively, even in a low-androgen environment or in the presence of AR inhibitors, thus promoting therapy resistance.[3][5]

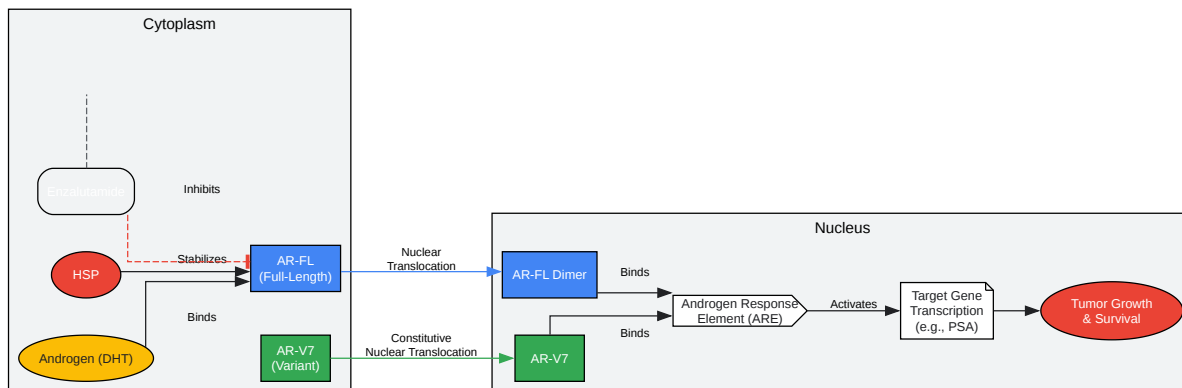

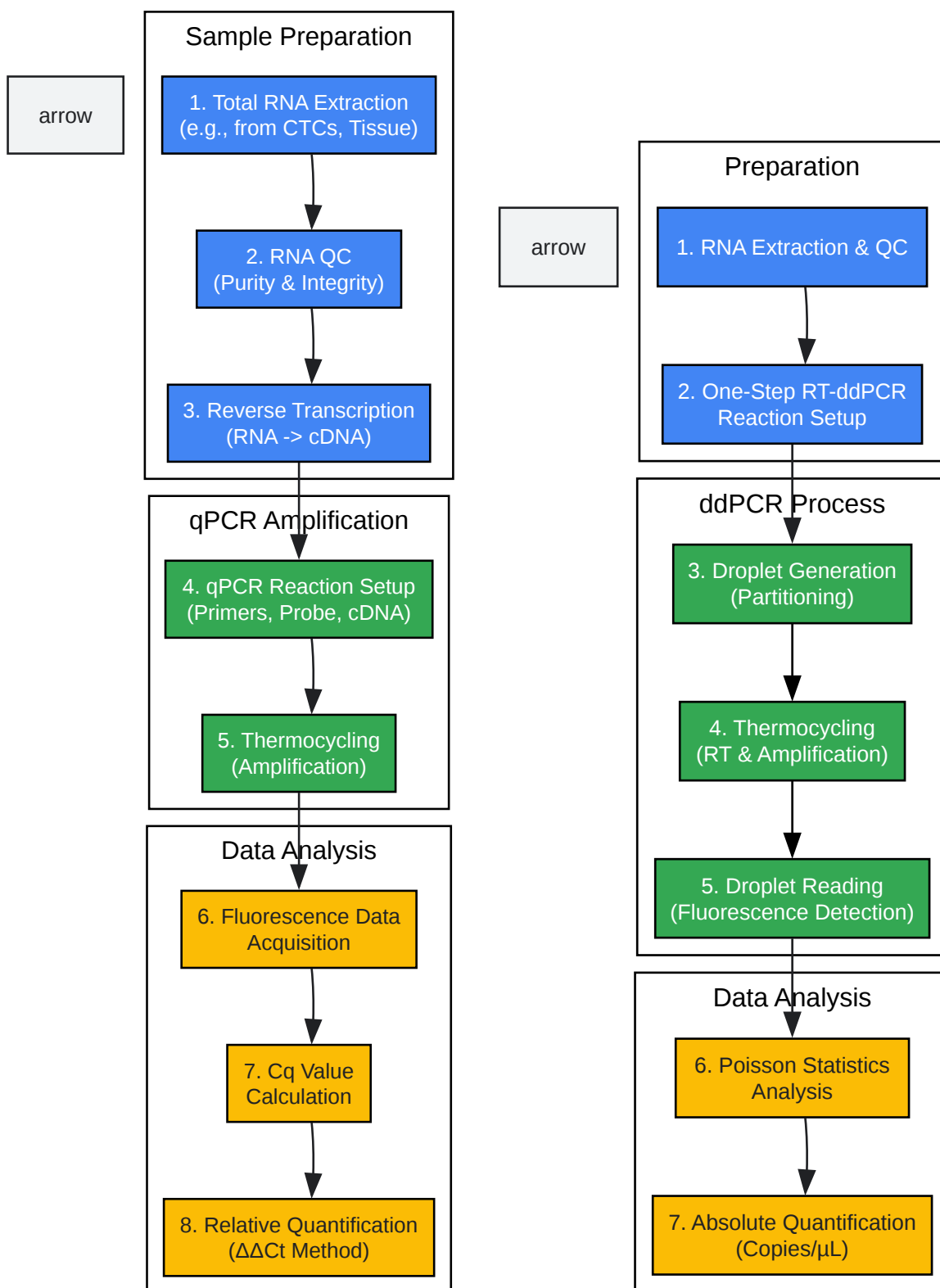

[Click to download full resolution via product page](#)

Need Custom Synthesis?

BenchChem offers custom synthesis for rare earth carbides and specific isotopic labeling.

Email: info@benchchem.com or [Request Quote Online](#).

References

- 1. [Frontiers | A compendium of Androgen Receptor Variant 7 target genes and their role in Castration Resistant Prostate Cancer \[frontiersin.org\]](#)
- 2. [Androgen receptor variant 7 \(AR-V7\) in sequencing therapeutic agents for castration resistant prostate cancer: A critical review - PMC \[pmc.ncbi.nlm.nih.gov\]](#)
- 3. [AR-V7 in Metastatic Prostate Cancer: A Strategy beyond Redemption - PMC \[pmc.ncbi.nlm.nih.gov\]](#)
- 4. [Therapeutic Approaches to Targeting Androgen Receptor Splice Variants - PubMed \[pubmed.ncbi.nlm.nih.gov\]](#)
- 5. [The Crucial Role of AR-V7 in Enzalutamide-Resistance of Castration-Resistant Prostate Cancer - PMC \[pmc.ncbi.nlm.nih.gov\]](#)
- To cite this document: BenchChem. [Application Notes and Protocols for the Quantification of AR-V7 mRNA]. BenchChem, [2026]. [Online PDF]. Available at: [\[https://www.benchchem.com/product/b605561/docs#application-notes-and-protocols-for-the-quantification-of-ar-v7-mrna\]](https://www.benchchem.com/product/b605561/docs#application-notes-and-protocols-for-the-quantification-of-ar-v7-mrna)

Disclaimer & Data Validity:

The information provided in this document is for Research Use Only (RUO) and is strictly not intended for diagnostic or therapeutic procedures. While BenchChem strives to provide accurate protocols, we make no warranties, express or implied, regarding the fitness of this product for every specific experimental setup.

Technical Support: The protocols provided are for reference purposes. Unsure if this reagent suits your experiment?

Need Industrial/Bulk Grade? [Request Custom Synthesis Quote](#)

BenchChem

Our mission is to be the trusted global source of essential and advanced chemicals, empowering scientists and researchers to drive progress in science and industry.

Contact

Address: 3281 E Guasti Rd

Ontario, CA 91761, United States

Phone: (601) 213-4426

Email: info@benchchem.com

[Contact our Ph.D. Support Team for a compatibility check](#)