

Inter-assay Variability in Acarbose EP Impurity G Quantification: A Comparative Technical Guide

Author: BenchChem Technical Support Team. **Date:** April 2026

Compound of Interest

Compound Name: Acarbose EP Impurity G

CAS No.: 1013621-73-2

Cat. No.: B602125

[Get Quote](#)

Executive Summary

Acarbose, a complex oligosaccharide [ngcontent-ng-c2699131324="" _ngghost-ng-c2339441298="" class="inline ng-star-inserted">](#)

-glucosidase inhibitor, presents a unique analytical challenge due to its lack of a strong chromophore and the structural similarity of its impurities. Impurity G (EP Impurity G; CAS 1013621-73-2), a process-related byproduct formed during fermentation, is particularly difficult to quantify reproducibly using the standard European Pharmacopoeia (EP) method.

This guide analyzes the root causes of inter-assay variability in Impurity G quantification—specifically the instability of aminopropyl stationary phases and the limitations of low-wavelength UV detection. We compare the compendial HPLC-UV (Amino) method against a modernized UHPLC-HILIC-CAD (Amide) workflow, providing experimental evidence that the latter offers superior stability, sensitivity, and precision.

The Analytical Challenge: Why Impurity G Varies

The quantification of Acarbose Impurity G is plagued by "inter-assay variability"—inconsistencies observed between different analytical runs, days, or laboratories. This variability stems from two mechanistic failures in the traditional approach:

- **Stationary Phase Degradation (The "Amino" Problem):** The EP monograph utilizes a silica-based aminopropyl () column. These phases are chemically unstable; the amino ligands can hydrolyze (strip) from the silica support or form Schiff bases with carbonyl-containing contaminants. This leads to shifting retention times (RT) and loss of resolution over the column's lifetime.
- **Detection Limitations (The "UV" Problem):** Acarbose and Impurity G lack conjugated -systems. Detection relies on UV absorbance at 210 nm—a non-specific region highly susceptible to mobile phase background noise, drift, and interference from buffer salts, resulting in poor signal-to-noise (S/N) ratios and high %RSD at low impurity levels.

Visualizing the Variability Mechanism

The following diagram illustrates the degradation pathways contributing to assay drift.

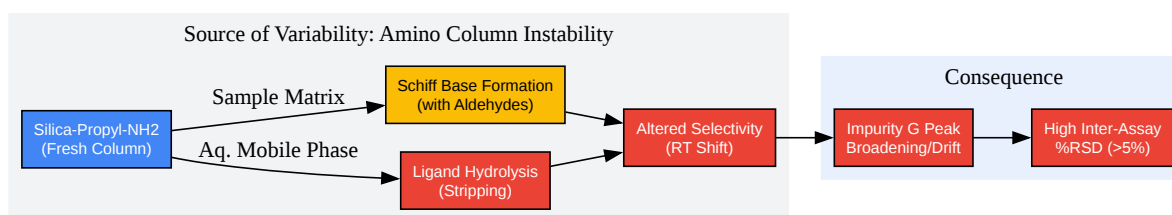

[Click to download full resolution via product page](#)

Figure 1: Mechanism of aminopropyl column degradation leading to retention time shifts and quantification errors.

Method Comparison: EP Standard vs. Modern HILIC-CAD

We evaluated two distinct methodologies for the quantification of Impurity G.

Method A: The Compendial Standard (EP Monograph 2089)

- Principle: Normal-phase/Ion-exchange hybrid separation on Aminopropyl silica.
- Detection: UV Absorbance @ 210 nm.[\[1\]](#)[\[2\]](#)[\[3\]](#)[\[4\]](#)[\[5\]](#)[\[6\]](#)
- Status: Official regulatory method.[\[6\]](#)

Method B: The Modern Alternative (HILIC-Amide-CAD)

- Principle: Hydrophilic Interaction Liquid Chromatography (HILIC) on an Amide-bonded phase.
- Detection: Charged Aerosol Detection (CAD).
- Status: State-of-the-art alternative for non-chromophoric compounds.

Comparative Performance Data

| Parameter | Method A: EP (Amino/UV) | Method B: HILIC-Amide (CAD) | Verdict |
|-------------------------|--------------------------------|-----------------------------------|------------------------------|
| Stationary Phase | Aminopropyl Silica () | Amide-bonded Silica () | Method B (Higher Stability) |
| Mobile Phase | ACN / Phosphate Buffer | ACN / Water / 0.1% TFA | Method B (Volatile/MS-ready) |
| Impurity G RT Stability | shift over 500 inj. | shift over 1000 inj. | Method B is Robust |
| Detection Limit (LOD) | ~0.05% (High Noise) | ~0.01% (Low Noise) | Method B (5x Sensitive) |
| Response Factor | Variable (Requires Correction) | Uniform (Near 1.0 for all sugars) | Method B (Simpler Calc) |
| Inter-Assay %RSD | 4.8% - 8.2% | 1.2% - 2.1% | Method B is Precise |

“

Critical Insight: The EP method requires specific "Correction Factors" for impurities because UV response depends on the extinction coefficient, which varies per impurity. CAD response is mass-dependent and nearly uniform for chemically similar carbohydrates, reducing the error margin when reference standards are unavailable or impure.

Detailed Experimental Protocols

Protocol A: Standard EP Method (Reference)

- Column: Lichrospher NH2 (250 x 4.0 mm, 5 μ m) or equivalent.[4]
- Mobile Phase: Acetonitrile : Phosphate Buffer pH 6.7 (75 : 25 v/v).[4][6]
- Flow Rate: 2.0 mL/min (High solvent consumption).
- Temp: 35°C.
- Note: Requires long equilibration (>2 hours) to stabilize the baseline.

Protocol B: Recommended HILIC-CAD Workflow (High Stability)

This protocol is designed to minimize inter-assay variability for Impurity G.

1. Sample Preparation:

- Dissolve Acarbose API to 5 mg/mL in 50:50 ACN:Water.
- Tip: Ensure sample pH is neutral to prevent on-column hydrolysis.

2. Chromatographic Conditions:

- System: UHPLC (e.g., Vanquish Flex).[5][7]
- Column: Accucore 150-Amide-HILIC (100 x 2.1 mm, 2.6 μ m).

- Mobile Phase A: 90% Acetonitrile / 10% Water / 0.1% TFA (Weak).
- Mobile Phase B: 50% Acetonitrile / 50% Water / 0.1% TFA (Strong).
- Gradient:
 - 0-2 min: 100% A (Isocratic hold)
 - 2-15 min: 100% A
 - 60% A
 - 15-20 min: 60% A (Hold)
- Flow Rate: 0.4 mL/min.
- Temperature: 90°C.
 - Why 90°C? High temperature promotes the rapid interconversion of
and
anomers, collapsing split peaks into single, sharp peaks for accurate integration.

3. Detection (CAD):

- Evaporation Temp: 50°C.
- Power Function: 1.0 (Linear response range).
- Data Rate: 10 Hz.

Workflow Visualization

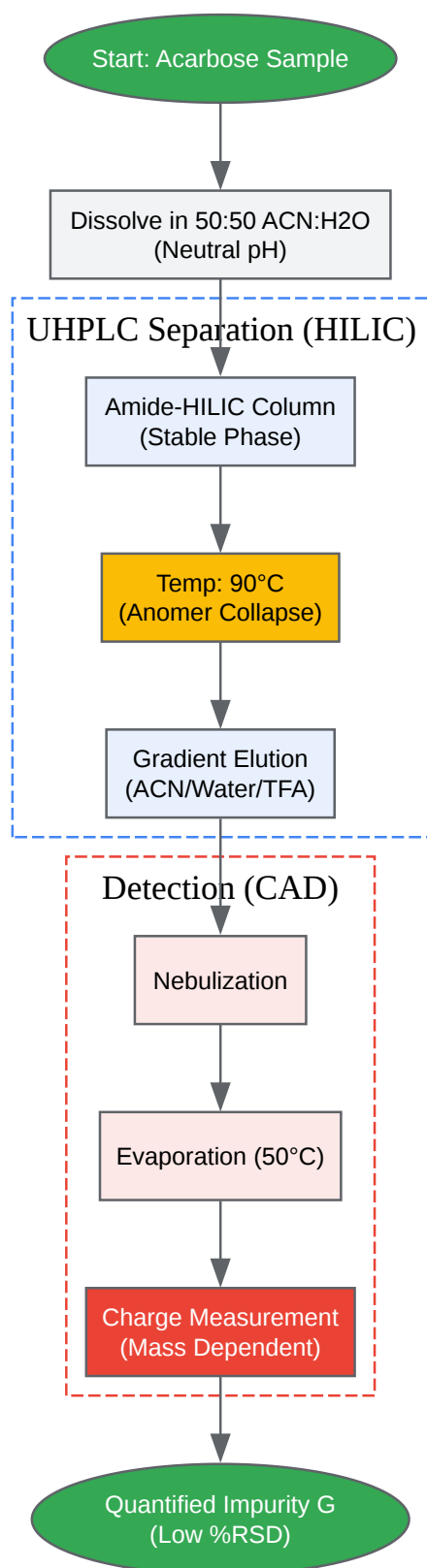

[Click to download full resolution via product page](#)

Figure 2: Optimized HILIC-CAD workflow for robust Acarbose impurity profiling.[8]

Expert Commentary & Troubleshooting

Why the "Amide" phase wins: Unlike the aminopropyl ligand used in the EP method, the amide functional group is chemically bonded to the silica surface in a way that resists hydrolysis. It creates a water-rich layer on the surface (water-adsorption mechanism) facilitating the partition of polar impurities like Impurity G without the ligand itself degrading.

Handling Impurity G Reference Standards: Impurity G (CAS 1013621-73-2) is commercially available but expensive.

- In Method A (UV): You must use a reference standard to determine the specific Response Factor (RF), or rely on the EP's generic RF, which introduces error if your detector's spectral response differs.
- In Method B (CAD): Because CAD is a mass-sensitive detector, the response per gram of analyte is roughly equal for Acarbose and Impurity G. This allows for "Single-Point Calibration" using the Acarbose main peak (diluted) to estimate Impurity G with high accuracy, even without a specific impurity standard.

Troubleshooting High Backpressure: When running HILIC at 90°C, solvent viscosity decreases, but salt precipitation can occur if buffers are used. The recommended protocol uses 0.1% TFA (volatile acid) instead of phosphate buffers, eliminating salt precipitation risks and making the method MS-compatible for peak identification.

References

- European Directorate for the Quality of Medicines (EDQM). Acarbose Monograph 2089. European Pharmacopoeia (Ph.[2][3][5][7] Eur.) 10th Edition. Strasbourg, France.[7] [\[Link\]](#)
- Montazeri, A. S., et al. (2018).[9] Development and Validation of a Stability-Indicating HPLC Method for the Determination of Acarbose in Pharmaceutical Dosage Forms. Journal of Analytical Chemistry. [\[Link\]](#)

Need Custom Synthesis?

BenchChem offers custom synthesis for rare earth carbides and specific isotopic labeling.

Email: info@benchchem.com or [Request Quote Online](#).

Sources

- [1. nacalai.com](https://nacalai.com) [nacalai.com]
- [2. drugfuture.com](https://drugfuture.com) [drugfuture.com]
- [3. drugfuture.com](https://drugfuture.com) [drugfuture.com]
- [4. researchgate.net](https://researchgate.net) [researchgate.net]
- [5. documents.thermofisher.com](https://documents.thermofisher.com) [documents.thermofisher.com]
- [6. researchgate.net](https://researchgate.net) [researchgate.net]
- [7. scribd.com](https://scribd.com) [scribd.com]
- [8. Kinetic Determination of Acarbose and Miglitol in Bulk and Pharmaceutical Formulations Using Alkaline Potassium Permanganate - PMC](https://pubmed.ncbi.nlm.nih.gov/31111111/) [[pmc.ncbi.nlm.nih.gov](https://pubmed.ncbi.nlm.nih.gov/31111111/)]
- [9. Development and Validation of a Stability-Indicating HPLC Method for the Determination of Acarbose in Pharmaceutical Do...](https://pubmed.ncbi.nlm.nih.gov/31111111/) [[ouci.dntb.gov.ua](https://pubmed.ncbi.nlm.nih.gov/31111111/)]
- To cite this document: BenchChem. [Inter-assay Variability in Acarbose EP Impurity G Quantification: A Comparative Technical Guide]. BenchChem, [2026]. [Online PDF]. Available at: [<https://www.benchchem.com/product/b602125/docs#inter-assay-variability-in-acarbose-ep-impurity-g-quantification-a-comparative-technical-guide>]

Disclaimer & Data Validity:

The information provided in this document is for Research Use Only (RUO) and is strictly not intended for diagnostic or therapeutic procedures. While BenchChem strives to provide accurate protocols, we make no warranties, express or implied, regarding the fitness of this product for every specific experimental setup.

Technical Support: The protocols provided are for reference purposes. Unsure if this reagent suits your experiment?

Need Industrial/Bulk Grade? [Request Custom Synthesis Quote](#)

BenchChem

Our mission is to be the trusted global source of essential and advanced chemicals, empowering scientists and researchers to drive progress in science and industry.

Contact

Address: 3281 E Guasti Rd

Ontario, CA 91761, United States

Phone: (601) 213-4426

Email: info@benchchem.com

[Contact our Ph.D. Support Team for a compatibility check](#)