

Technical Support Center: Mitigating Brimonidine Impurity F (Photo-Oxidation Control)

Author: BenchChem Technical Support Team. **Date:** February 2026

Compound of Interest

Compound Name: 4,5-Didehydro Brimonidine

CAS No.: 151110-15-5

Cat. No.: B601883

[Get Quote](#)

Status: Operational Ticket Focus: Photostability & Impurity F Excursions Assigned Specialist: Senior Application Scientist, Stability Division

Executive Summary

Welcome to the Brimonidine Technical Support Center. If you are accessing this guide, you are likely observing out-of-specification (OOS) or aberrant results for Impurity F in Brimonidine Tartrate drug substance or drug product.

Technical Definition: In the context of European Pharmacopoeia (EP) and general stability profiling, Impurity F is typically identified as 5-bromo-N-(1H-imidazol-2-yl)quinoxalin-6-amine.[1]

The Core Issue: Unlike hydrolytic impurities driven by moisture or pH, Impurity F is primarily formed via photo-oxidative dehydrogenation. The imidazoline ring of Brimonidine absorbs UV/Vis energy, leading to aromatization into an imidazole ring. This process is distinct from thermal degradation, making standard temperature controls ineffective if light exposure is uncontrolled.

Part 1: Diagnostic & Root Cause Analysis

Q: Why is Impurity F spiking even though my temperature is controlled at 25°C?

A: You are likely treating a photochemical problem with a thermodynamic solution. Brimonidine contains a quinoxaline ring conjugated with an imidazoline ring.[2] This structure is a chromophore that absorbs light in the UV-A and visible spectrum. When Brimonidine absorbs photons, it enters an excited singlet state. In the presence of oxygen, this energy drives the removal of hydrogen from the 4,5-dihydroimidazoline ring, converting it into the fully aromatic imidazole analog (Impurity F).

Key Differentiator:

- Thermal Stress: Typically leads to hydrolysis (Ring opening).
- Light Stress: Leads to Oxidation (Impurity F) and Debromination.

Visualizing the Mechanism The following diagram illustrates the specific pathway causing your impurity spike.

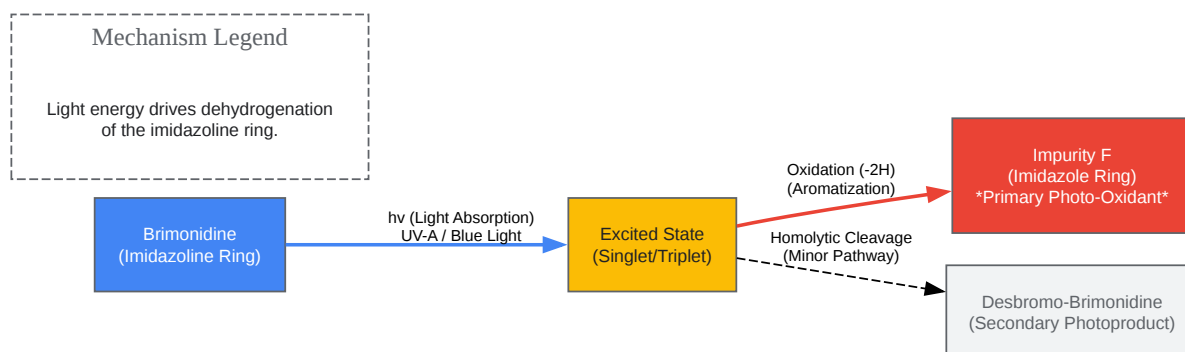

[Click to download full resolution via product page](#)

Figure 1: The photo-oxidative pathway converting Brimonidine to Impurity F via ring aromatization.

Part 2: Experimental Troubleshooting (The "How-To")

Q: How do I confirm light is the culprit versus a formulation incompatibility?

A: You must perform a Confirmatory Photostability Study with a strict Dark Control. Do not rely on historical data. Perform this side-by-side experiment to validate your current batch and packaging.

Protocol: The "Dark Control" Validation System Reference Standard: ICH Q1B Photostability Testing of New Drug Substances and Products.[3]

Step	Action	Technical Rationale
1. Prep	Prepare two identical sets of samples (e.g., 3 vials each).	Eliminates formulation variability.
2. Shield	Wrap Set A (Dark Control) tightly in aluminum foil.	Creates a complete photon barrier. If Impurity F appears here, the cause is chemical (e.g., oxidant in excipients), not light.
3. Expose	Place Set B (Light Exposed) and Set A in the photostability chamber.	Ensures both sets experience the exact same temperature environment.
4. Dose	Expose to ≥ 1.2 million lux hours AND ≥ 200 Wh/m ² UV energy.[3][4]	Minimum ICH Q1B requirement for confirmatory testing.
5. Analyze	Assay both sets immediately via HPLC.	Minimizes post-exposure reactions.

Interpreting Your Results:

Dark Control (Set A)	Light Exposed (Set B)	Diagnosis	Remediation
< 0.1%	> 0.5% (High)	Confirmed Photodegradation	Upgrade packaging (opacity); limit exposure during manufacturing.
> 0.5%	> 0.5%	Chemical Oxidation	Check excipients for peroxides; investigate metal chelators. Light is not the root cause.
< 0.1%	< 0.1%	Stable	Current process is robust. Spike may be an analytical artifact.

Part 3: Analytical Challenges & Artifacts

Q: I see Impurity F in my standard solution. Is my reference standard degrading?

A: Yes, Brimonidine reference standards are notoriously photosensitive in solution. A common error is preparing standards in clear glassware under fluorescent lab lights.

Corrective Workflow:

- Amber Everything: Use low-actinic (amber) volumetric flasks for all standard preparations.
- The "Red Light" Rule: If possible, perform weighing and dilution under yellow/red safe lights, or minimize exposure time to <5 minutes under normal lab lighting.
- Auto-Sampler Protection: Ensure your HPLC auto-sampler has a darkened door or opaque cover. Brimonidine sitting in a clear vial in a lit auto-sampler for 12 hours will generate Impurity F artifacts, leading to false OOS results.

Part 4: Decision Tree & Mitigation

Q: My drug product is failing. What are my options?

A: Use the decision tree below to select the correct mitigation strategy based on your stage of development.

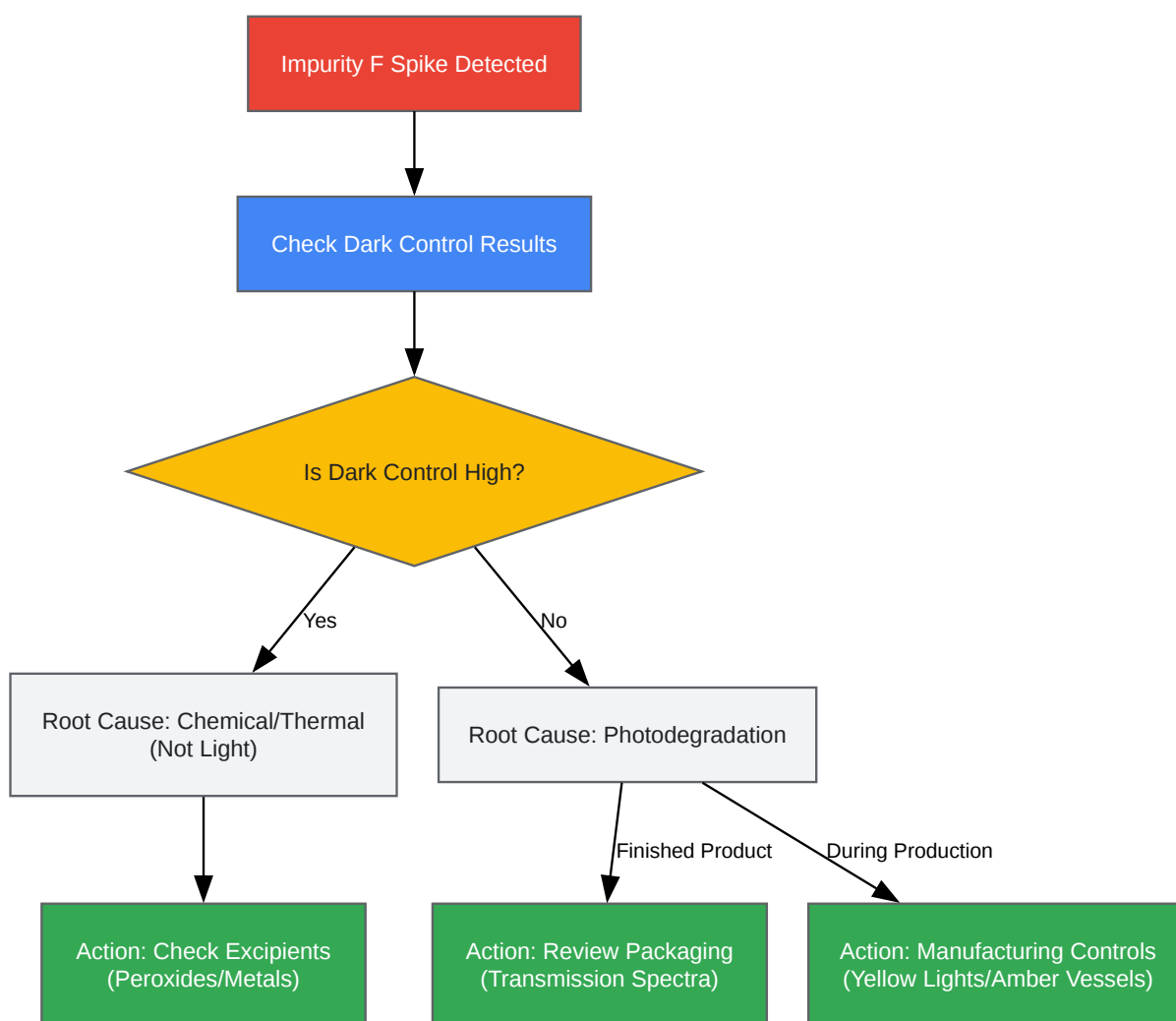

[Click to download full resolution via product page](#)

Figure 2: Troubleshooting logic for distinguishing chemical vs. photochemical degradation.

Specific Packaging Recommendations:

- Liquids (Eye Drops): LDPE bottles are often insufficient for UV blocking. Consider adding UV-blocking additives to the plastic polymer or using secondary packaging (opaque carton) that remains on until use.

- Solids: Blister packs must be cold-form aluminum (Alu/Alu) rather than clear PVC/PVDC if the tablet coating does not contain TiO₂ or iron oxides sufficient to block light.

References

- International Council for Harmonisation (ICH). Guideline Q1B: Photostability Testing of New Drug Substances and Products. [3] (1996). [3][5] Defines the standard light sources (D65/ID65) and exposure limits (1.2M lux hours).
- European Pharmacopoeia (Ph. Eur.). Brimonidine Tartrate Monograph. Identifies specific impurities including Impurity F (5-bromo-N-(1H-imidazol-2-yl)quinoxalin-6-amine). [1][6]
- PubChem. Brimonidine Tartrate Compound Summary. National Library of Medicine. Provides chemical structure and physical property data supporting the quinoxaline chromophore theory.
- Baertschi, S. W., et al. Pharmaceutical Photostability: A Technical Guide and Practical Strategies. Demonstrates the mechanism of oxidative dehydrogenation in nitrogen-heterocycles under light exposure.

Need Custom Synthesis?

BenchChem offers custom synthesis for rare earth carbides and specific isotopic labeling.

Email: info@benchchem.com or [Request Quote Online](#).

Sources

- 1. glppharmastandards.com [glppharmastandards.com]
- 2. Brimonidine | C₁₁H₁₀BrN₅ | CID 2435 - PubChem [pubchem.ncbi.nlm.nih.gov]
- 3. academia.edu [academia.edu]
- 4. q1scientific.com [q1scientific.com]
- 5. Brimonidine - Wikipedia [en.wikipedia.org]
- 6. veeprho.com [veeprho.com]
- To cite this document: BenchChem. [Technical Support Center: Mitigating Brimonidine Impurity F (Photo-Oxidation Control)]. BenchChem, [2026]. [Online PDF]. Available at:

[\[https://www.benchchem.com/product/b601883#impact-of-light-exposure-on-brimonidine-impurity-f-levels\]](https://www.benchchem.com/product/b601883#impact-of-light-exposure-on-brimonidine-impurity-f-levels)

Disclaimer & Data Validity:

The information provided in this document is for Research Use Only (RUO) and is strictly not intended for diagnostic or therapeutic procedures. While BenchChem strives to provide accurate protocols, we make no warranties, express or implied, regarding the fitness of this product for every specific experimental setup.

Technical Support: The protocols provided are for reference purposes. Unsure if this reagent suits your experiment? [[Contact our Ph.D. Support Team for a compatibility check](#)]

Need Industrial/Bulk Grade? [Request Custom Synthesis Quote](#)

BenchChem

Our mission is to be the trusted global source of essential and advanced chemicals, empowering scientists and researchers to drive progress in science and industry.

Contact

Address: 3281 E Guasti Rd
Ontario, CA 91761, United States
Phone: (601) 213-4426
Email: info@benchchem.com