

Technical Support Center: Method Validation for 5,6-Dehydro-17 β -dutasteride

Author: BenchChem Technical Support Team. **Date:** May 2026

Compound of Interest

Compound Name: 5,6-Dehydro-17beta-dutasteride

CAS No.: 1430804-85-5

Cat. No.: B601954

[Get Quote](#)

Welcome to the technical support resource for the analytical challenges surrounding 5,6-Dehydro-17 β -dutasteride. This guide is designed for researchers, analytical scientists, and drug development professionals. It provides in-depth, field-proven insights into developing and validating robust analytical methods for this critical impurity of Dutasteride.

Introduction

5,6-Dehydro-17 β -dutasteride is a known process impurity and potential degradant of Dutasteride, a potent dual inhibitor of 5 α -reductase used in the treatment of benign prostatic hyperplasia (BPH).[1][2] As a structurally similar compound, its accurate detection and quantification are paramount for ensuring the quality, safety, and efficacy of the final drug product. Regulatory bodies require that impurities at levels greater than 0.1% be identified and characterized, making a validated, stability-indicating analytical method essential.[3]

This guide addresses the common hurdles encountered during the method validation for this specific analyte, moving from general questions to specific, hands-on troubleshooting protocols.

Section 1: Frequently Asked Questions (FAQs)

Q1: What is 5,6-Dehydro-17 β -dutasteride and why is its control critical?

5,6-Dehydro-17 β -dutasteride (also known as Dutasteride EP Impurity G) is an impurity that can arise during the synthesis of Dutasteride.[1] It is characterized by a double bond between the 5th and 6th carbon positions of the steroid core. The presence of this additional unsaturation makes it structurally distinct from the active pharmaceutical ingredient (API). Controlling its level is critical because impurities can potentially have their own pharmacological or toxicological effects, and their presence can impact the overall safety profile of the drug. Pharmacopoeial standards and regulatory guidelines, such as those from the ICH, mandate strict limits on impurities in drug substances and products.[3]

Q2: What are the primary analytical techniques for quantifying this impurity?

The most common and effective techniques are high-performance liquid chromatography (HPLC) and ultra-performance liquid chromatography (UPLC), typically with UV/photodiode array (PDA) detection.[4][5] For higher sensitivity and specificity, especially during impurity identification or analysis in complex matrices, liquid chromatography-mass spectrometry (LC-MS/MS) is the preferred method.[6][7][8] LC-MS/MS is particularly powerful for distinguishing between isomers and other structurally related impurities that may have identical molecular weights.[3][7]

Q3: What are the key regulatory guidelines I should follow for method validation?

The primary guideline for validating analytical procedures is the ICH Q2(R1) "Validation of Analytical Procedures: Text and Methodology".[4][9] This document outlines the validation characteristics required for an impurity quantification method, which include:

- **Specificity:** The ability to assess the analyte unequivocally in the presence of other components, including the API, other impurities, and degradants.
- **Linearity:** Demonstrating a direct proportional relationship between analyte concentration and method response over a defined range.
- **Range:** The interval between the upper and lower concentrations of the analyte that have been demonstrated to have a suitable level of precision, accuracy, and linearity.

- Accuracy: The closeness of test results to the true value.
- Precision: The degree of agreement among individual test results when the procedure is applied repeatedly to multiple samplings of a homogeneous sample. This includes repeatability (intra-day) and intermediate precision (inter-day, inter-analyst).
- Limit of Quantification (LOQ): The lowest amount of analyte in a sample that can be quantitatively determined with suitable precision and accuracy.
- Limit of Detection (LOD): The lowest amount of analyte in a sample that can be detected but not necessarily quantitated as an exact value.
- Robustness: A measure of the method's capacity to remain unaffected by small, but deliberate, variations in method parameters.

Section 2: Troubleshooting Guide for Method Development & Validation

This section addresses specific experimental problems in a question-and-answer format, providing causal explanations and actionable solutions.

Chromatography Issues

Q: My 5,6-Dehydro-17 β -dutasteride peak is co-eluting with the Dutasteride API or another impurity. How can I improve the resolution?

A: Co-elution is the primary challenge due to the high structural similarity between Dutasteride and its impurities. The key is to exploit the subtle differences in their physicochemical properties.

- Causality: The 5,6-double bond in the impurity introduces planarity and affects the molecule's hydrophobicity and electronic distribution compared to the saturated A-ring of Dutasteride. Standard C18 columns, which separate primarily based on hydrophobicity, may not be sufficient.
- Solutions:

- Change Column Chemistry: Move beyond a standard C18.
 - Phenyl-Hexyl or Biphenyl Phases: These columns offer alternative selectivity through π - π interactions with the aromatic rings and the double bond system of the impurity. This is often the most effective strategy.
 - Embedded Polar Group (EPG) Columns: Columns with polar functionalities (like amide or carbamate) can provide different interactions and improve peak shape for these types of compounds.
- Modify Mobile Phase Composition:
 - Vary the Organic Solvent: Switching from acetonitrile to methanol (or using a combination) can alter selectivity. Methanol is a hydrogen-bond donor and acceptor, while acetonitrile is a strong dipole, leading to different interactions with the analytes and stationary phase.^[9]
 - Adjust pH: If using a buffer, small changes in pH can alter the ionization state of silanols on the column, affecting secondary interactions and potentially improving resolution.
- Optimize Temperature: Increasing the column temperature reduces mobile phase viscosity and can improve efficiency, but it can also change selectivity. Experiment with a range (e.g., 25°C to 45°C) to find the optimal balance.
- Implement a Shallow Gradient: A very slow, shallow gradient around the elution time of the critical pair can often provide the necessary resolution that isocratic methods cannot.

Q: I am observing poor peak shape (tailing) for the 5,6-Dehydro-17 β -dutasteride peak, especially at low concentrations. What are the likely causes?

A: Peak tailing is typically caused by unwanted secondary interactions between the analyte and the stationary phase or by issues with the chromatographic setup.

- Causality: The 4-aza-steroid structure contains nitrogen atoms that can interact with acidic, free silanol groups on the silica backbone of the HPLC column. This is a common issue with amine-containing compounds.

- Solutions:
 - Use a High-Purity, End-Capped Column: Modern columns with high-purity silica and thorough end-capping have fewer free silanol groups, minimizing these secondary interactions.
 - Modify the Mobile Phase: Add a small amount of a competing base, such as 0.1% triethylamine (TEA) or a volatile alternative like ammonium hydroxide for LC-MS, to the mobile phase. These agents will bind to the active silanol sites, preventing the analyte from interacting with them.
 - Check Sample Diluent: Ensure your sample is dissolved in a solvent that is no stronger than the mobile phase. Injecting in a very strong solvent can cause peak distortion.
 - Reduce Extra-Column Volume: Ensure all tubing is cut clean and square, and use the minimum length and smallest internal diameter possible between the injector, column, and detector to prevent peak broadening.

Detection & Sensitivity Issues

Q: I am struggling to achieve the required Limit of Quantification (LOQ) of <0.1% for the impurity using HPLC-UV. How can I improve sensitivity?

A: Reaching low LOQs for impurities requires optimizing the signal-to-noise ratio (S/N).

- Causality: The signal is determined by the analyte's molar absorptivity at the chosen wavelength, while noise originates from the detector electronics and mobile phase impurities.
- Solutions:
 - Optimize Detection Wavelength: While Dutasteride is often monitored around 235-274 nm, the 5,6-dehydro impurity, with its extended conjugation, may have a different absorption maximum.^{[4][9]} Use a PDA detector to scan the UV spectrum of the impurity standard and select the wavelength of maximum absorbance to maximize the signal.
 - Increase Injection Volume: A larger injection volume puts more analyte on the column, directly increasing the peak height. Be cautious not to overload the column with the API,

which can distort both the API and nearby impurity peaks.

- Use High-Purity Solvents: Ensure you are using high-purity, HPLC-grade or MS-grade solvents to minimize baseline noise.
- Increase Detector Path Length: If available, use a detector cell with a longer path length (e.g., a 60 mm cell instead of a standard 10 mm) to increase the absorbance signal according to the Beer-Lambert law.
- Switch to LC-MS: If UV sensitivity is insufficient, LC-MS is the definitive solution. It offers significantly lower detection limits and provides mass confirmation.[\[6\]](#)[\[10\]](#)

Analyte Stability & Sample Preparation

Q: I suspect my 5,6-Dehydro-17 β -dutasteride reference standard is degrading in my prepared solutions. How can I confirm this and prevent it?

A: The additional double bond in 5,6-Dehydro-17 β -dutasteride makes it potentially more susceptible to oxidation or photolytic degradation than the parent drug.

- Causality: Unsaturated systems can be sensitive to light, oxygen, and extreme pH. Dutasteride itself has been shown to degrade under various stress conditions.[\[11\]](#)
- Solution: Perform a Solution Stability Study:
 - Prepare a solution of the impurity standard in your chosen sample diluent.
 - Divide the solution into several vials. Store them under different conditions:
 - Benchtop (ambient light and temperature)
 - Autosampler (typically refrigerated, e.g., 4°C)
 - Protected from light (in an amber vial or wrapped in foil)
 - Analyze the solutions immediately after preparation (T=0) and at subsequent time points (e.g., 4, 8, 12, 24, 48 hours).

- Compare the peak area of the impurity at each time point to the T=0 result. A significant decrease in area or the appearance of new peaks indicates degradation.
- Prevention:
 - Use Amber Vials: Always use amber glass vials to protect solutions from light.
 - Refrigerate Samples: Store prepared samples and stock solutions in the refrigerator (2-8°C) when not in use.
 - Prepare Fresh: For the most accurate results, prepare solutions fresh daily and analyze them within a validated stability window.
 - Inert Atmosphere: If the analyte is highly sensitive to oxidation, consider sparging the diluent with nitrogen or argon before preparation.

Section 3: Protocols & Workflows

Protocol 1: Recommended Starting RP-HPLC-UV

Method

This protocol provides a robust starting point for separating Dutasteride from 5,6-Dehydro-17 β -dutasteride. Optimization will be required.

Parameter	Recommended Condition
Column	Phenyl-Hexyl or Biphenyl phase, 4.6 x 150 mm, 3.5 μ m
Mobile Phase A	0.1% Formic Acid in Water
Mobile Phase B	0.1% Formic Acid in Acetonitrile
Gradient	50% B to 70% B over 15 minutes, then wash and re-equilibrate
Flow Rate	1.0 mL/min
Column Temperature	35°C
Detection	PDA Detector, monitor at 240 nm (verify optimal wavelength for impurity)
Injection Volume	10 μ L
Sample Diluent	Acetonitrile:Water (50:50 v/v)

Workflow Diagram: General Method Validation for an Impurity

This diagram outlines the logical flow for validating an analytical method for 5,6-Dehydro-17 β -dutasteride according to ICH Q2(R1) guidelines.

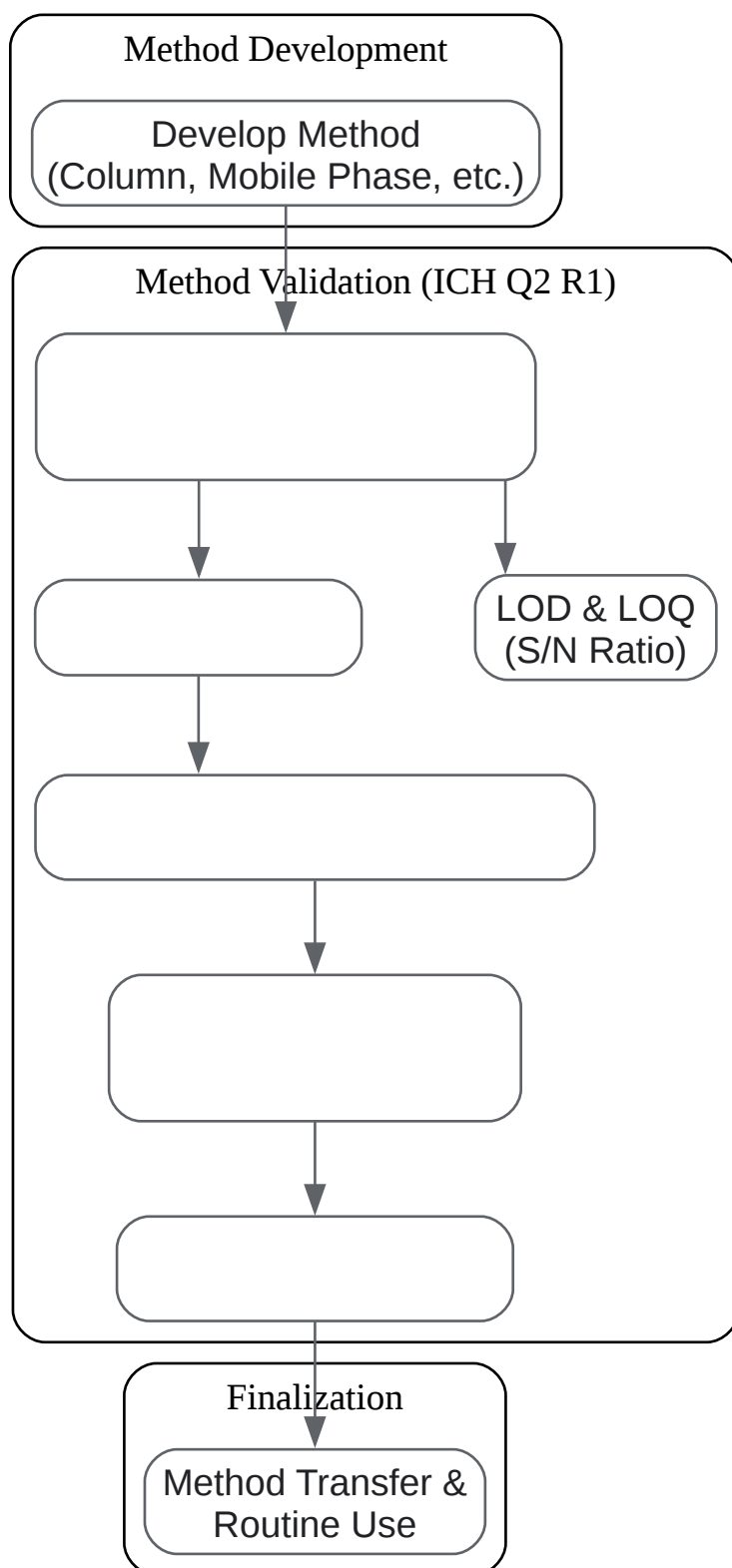

[Click to download full resolution via product page](#)

Caption: Workflow for impurity method validation.

Troubleshooting Diagram: Resolving Co-elution

This decision tree guides the user through steps to resolve poor chromatographic separation.

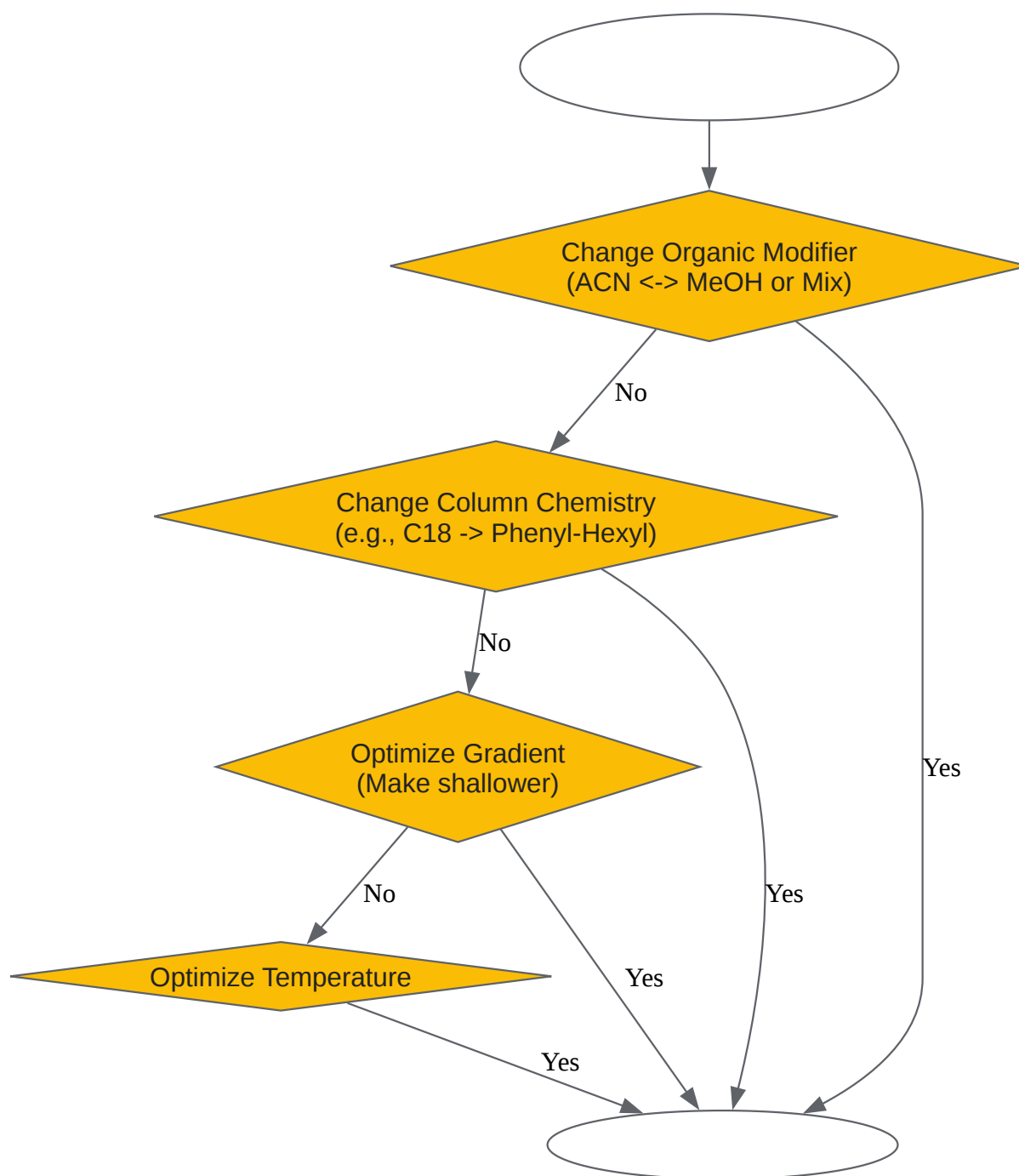

[Click to download full resolution via product page](#)

Caption: Decision tree for troubleshooting co-elution.

Section 4: Data Presentation

Table 1: Typical Validation Acceptance Criteria (per ICH Q2 R1)

Validation Parameter	Acceptance Criteria for an Impurity Method
Specificity	Peak purity index > 0.999. Baseline resolution (>1.5) from closest eluting peak.
Linearity (r ²)	Correlation coefficient (r ²) ≥ 0.995.
Range	From LOQ to 120% of the specification limit.
Accuracy (% Recovery)	Typically 80.0% to 120.0% of the nominal concentration.
Precision (%RSD)	Repeatability (n=6): ≤ 10.0% RSD at the LOQ; ≤ 5.0% RSD at specification limit.
Intermediate Precision: ≤ 15.0% RSD at the LOQ; ≤ 10.0% RSD at spec. limit.	
LOQ	Signal-to-Noise ratio ≥ 10. Must meet accuracy and precision criteria.
Robustness	%RSD of results should be within acceptable limits (e.g., < 10%) after variations.

References

- A concise review- Development of an analytical method and validation of dutasteride. (n.d.). Retrieved from [\[Link\]](#)
- Bruna, E., et al. (2019). Detection of 5α-reductase inhibitors by UPLC-MS/MS: Application to the definition of the excretion profile of dutasteride in urine. PubMed. Retrieved from [\[Link\]](#)

- Kaza, M., et al. (2021). LC-MS/MS determination of dutasteride and its major metabolites in human plasma. Journal of Pharmaceutical and Biomedical Analysis. Retrieved from [\[Link\]](#)
- Mulla, S., et al. (2013). Synthesis, Isolation, and Characterization of Isomeric Impurity of Dutasteride. IOSR Journal of Applied Chemistry. Retrieved from [\[Link\]](#)
- Priyadarshani, M., et al. (2015). Analytical method development and validation of dutasteride with tamsulosin in pharmaceutical capsule dosage form by rp-hplc method. International Journal of Pharmacy. Retrieved from [\[Link\]](#)
- Determination of Dutasteride by LC: Validation and Application of the Method. (n.d.). Retrieved from [\[Link\]](#)
- Sliwiak, J., et al. (2014). Characterization of dutasteride polymorphic forms. science24.com. Retrieved from [\[Link\]](#)
- Patel, V., et al. (2021). Analytical Method Development and Validation for the Quantitative Estimation of Dutasteride in Its Tablet Dosage Form by RP-HPLC. International Journal of Creative Research Thoughts. Retrieved from [\[Link\]](#)
- A concise review- Development of an analytical method and validation of dutasteride. (n.d.). Retrieved from [\[Link\]](#)
- Satyanarayana, K., et al. (2007). Impurity profile study of dutasteride. ResearchGate. Retrieved from [\[Link\]](#)
- Google Patents. (2015). CN103044517B - Preparation method of five dutasteride impurities.
- Rao, V., et al. (2015). Development and Validation of a Stability Indicating Liquid Chromatographic Method for Simultaneous Estimation of Dutasteride and Tamsulosin in Combined Dosage Form. Oriental Journal of Chemistry. Retrieved from [\[Link\]](#)
- Patel, D., et al. (2011). RP-HPLC Method for the Estimation of Dutasteride in Tablet Dosage Form. Indian Journal of Pharmaceutical Sciences. Retrieved from [\[Link\]](#)
- Satyanarayana, K., et al. (2007). Impurity profile study of dutasteride. PubMed. Retrieved from [\[Link\]](#)

Need Custom Synthesis?

BenchChem offers custom synthesis for rare earth carbides and specific isotopic labeling.

Email: info@benchchem.com or [Request Quote Online](#).

Sources

- 1. 5,6-Dehydro-17 β -dutasteride | 1430804-85-5 [chemicalbook.com]
- 2. pharmascholars.com [pharmascholars.com]
- 3. iosrjournals.org [iosrjournals.org]
- 4. ijcrt.org [ijcrt.org]
- 5. Development and Validation of a Stability Indicating Liquid Chromatographic Method for Simultaneous Estimation of Dutasteride and Tamsulosin in Combined Dosage Form – Oriental Journal of Chemistry [orientjchem.org]
- 6. Detection of 5 α -reductase inhibitors by UPLC-MS/MS: Application to the definition of the excretion profile of dutasteride in urine - PubMed [pubmed.ncbi.nlm.nih.gov]
- 7. researchgate.net [researchgate.net]
- 8. Impurity profile study of dutasteride - PubMed [pubmed.ncbi.nlm.nih.gov]
- 9. RP-HPLC Method for the Estimation of Dutasteride in Tablet Dosage Form - PMC [pmc.ncbi.nlm.nih.gov]
- 10. LC-MS/MS determination of dutasteride and its major metabolites in human plasma - PubMed [pubmed.ncbi.nlm.nih.gov]
- 11. researchgate.net [researchgate.net]
- To cite this document: BenchChem. [Technical Support Center: Method Validation for 5,6-Dehydro-17 β -dutasteride]. BenchChem, [2026]. [Online PDF]. Available at: [<https://www.benchchem.com/product/b601954/docs#technical-support-center-method-validation-for-5-6-dehydro-17-dutasteride>]

Disclaimer & Data Validity:

The information provided in this document is for Research Use Only (RUO) and is strictly not intended for diagnostic or therapeutic procedures. While BenchChem strives to provide

accurate protocols, we make no warranties, express or implied, regarding the fitness of this product for every specific experimental setup.

Technical Support: The protocols provided are for reference purposes. Unsure if this reagent suits your experiment?

Need Industrial/Bulk Grade? [Request Custom Synthesis Quote](#)

BenchChem

Our mission is to be the trusted global source of essential and advanced chemicals, empowering scientists and researchers to drive progress in science and industry.

Contact

Address: 3281 E Guasti Rd

Ontario, CA 91761, United States

Phone: (601) 213-4426

Email: info@benchchem.com

[Contact our Ph.D. Support Team for a compatibility check](#)