

# Developing LC-MS/MS methods for quantifying (2S,4S)-Argatroban in plasma

**Author:** BenchChem Technical Support Team. **Date:** May 2026

## Compound of Interest

Compound Name: (2S,4S)-Argatroban

CAS No.: 189264-03-7

Cat. No.: B601580

[Get Quote](#)

## Application and Protocol Guide: A Robust and Validated LC-MS/MS Method for the Quantification of (2S,4S)-Argatroban in Human Plasma

### Abstract

This document details a comprehensive, high-throughput liquid chromatography-tandem mass spectrometry (LC-MS/MS) method for the precise and accurate quantification of **(2S,4S)-Argatroban** in human plasma. Argatroban, a direct thrombin inhibitor, is a critical anticoagulant used in clinical settings where heparin is contraindicated.[1][2][3] The method described herein employs a straightforward protein precipitation extraction technique and has been rigorously validated according to the principles outlined in the ICH M10 Bioanalytical Method Validation guideline.[4] This application note provides a complete protocol, from sample preparation to data acquisition and analysis, intended for researchers, scientists, and professionals in drug development and clinical monitoring.

## Introduction: The Clinical Imperative for Argatroban Quantification

Argatroban is a synthetic, small-molecule direct thrombin inhibitor.[2] It functions by reversibly binding to the active site of thrombin, thereby inhibiting fibrin formation, platelet aggregation, and the activation of coagulation factors V, VIII, and XIII.[5][6] Unlike heparin, its action is independent of antithrombin III and it can inhibit both free and clot-associated thrombin.[3][5]

Argatroban is commercially available as a mixture of (2R,4R) and (2S,4S) diastereomers.[5] The (2S,4S) isomer is the active pharmacological agent. Accurate quantification of this specific isomer in plasma is paramount for pharmacokinetic studies, therapeutic drug monitoring (TDM), and ensuring patient safety, particularly in critically ill patients where coagulation parameters can be highly variable.[7] LC-MS/MS offers unparalleled sensitivity and selectivity for this purpose, overcoming the limitations of traditional coagulation assays which can be influenced by other physiological factors.[8][9]

## Method Overview: A Streamlined Workflow for Reliable Results

The developed method is designed for efficiency and robustness, ensuring a rapid turnaround time without compromising data quality. The workflow is summarized in the diagram below.

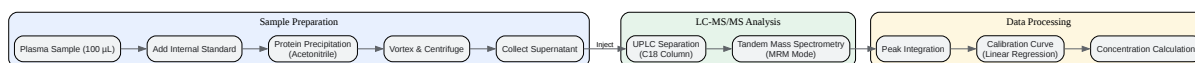

[Click to download full resolution via product page](#)

Caption: Overall workflow from plasma sample to final concentration.

## Experimental Design and Rationale

### Sample Preparation: Protein Precipitation

Rationale: Protein precipitation is a rapid and effective method for removing the majority of proteins from plasma samples, which can interfere with LC-MS/MS analysis.[10][11] Acetonitrile is chosen as the precipitating agent due to its high efficiency in denaturing and precipitating plasma proteins.[12] This "solvent-first" approach, where the sample is added to the solvent, often results in finer protein precipitates and cleaner extracts.[10]

Internal Standard (IS) Selection: The use of an internal standard is crucial for correcting for variability during sample preparation and analysis.[13] A stable isotope-labeled (SIL) version of Argatroban is the gold standard as it shares near-identical physicochemical properties with the analyte, ensuring it tracks consistently through the extraction and ionization process.[14][15] If a SIL-IS is not available, a structural analog with similar chromatographic behavior and ionization efficiency, such as Diclofenac as demonstrated in some studies, can be utilized.[8][9] [16]

## Liquid Chromatography

Rationale: A reversed-phase C18 column is selected for its proven ability to retain and separate a wide range of small molecules, including Argatroban.[7][9] A gradient elution with a mobile phase consisting of acidified water (typically with formic acid) and an organic solvent (methanol or acetonitrile) allows for efficient separation of Argatroban from endogenous plasma components and ensures a sharp peak shape for sensitive detection.[8][9] The addition of formic acid aids in the protonation of Argatroban, which is beneficial for positive ion electrospray ionization.

## Mass Spectrometry

Rationale: Tandem mass spectrometry operating in Multiple Reaction Monitoring (MRM) mode provides the high selectivity and sensitivity required for bioanalytical quantification.[8][9] This technique involves selecting the protonated molecular ion ( $[M+H]^+$ ) of Argatroban in the first quadrupole (Q1), fragmenting it in the collision cell (Q2), and then monitoring a specific, stable product ion in the third quadrupole (Q3). This precursor-to-product ion transition is highly specific to the analyte, minimizing the potential for interference from other compounds in the matrix.

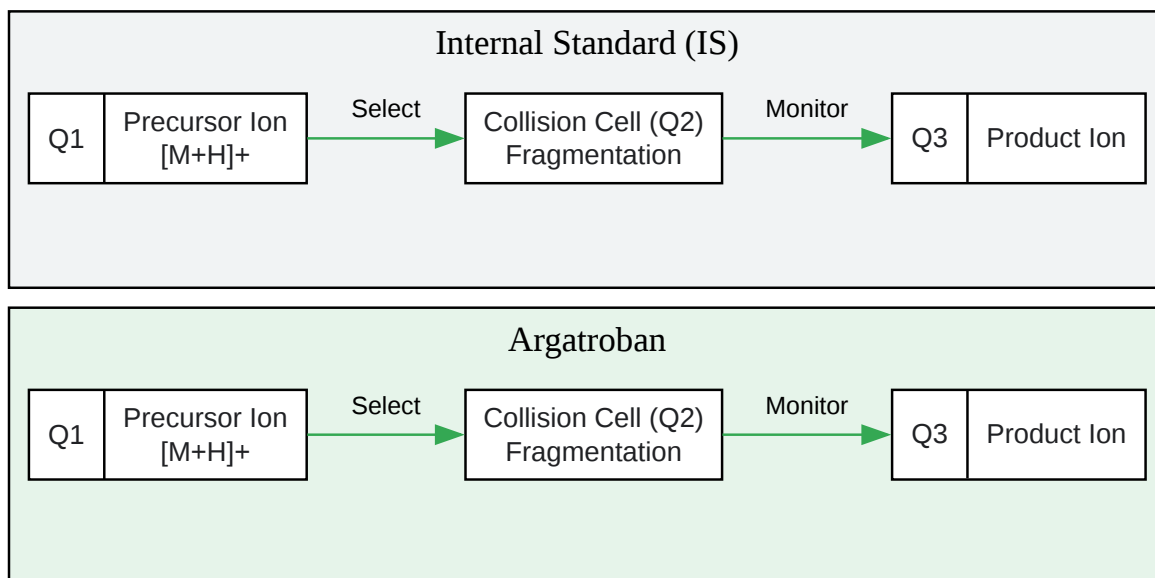

[Click to download full resolution via product page](#)

Caption: Principle of Multiple Reaction Monitoring (MRM) for analyte and IS.

## Detailed Protocols

### Preparation of Stock and Working Solutions

- Primary Stock Solution (1 mg/mL): Accurately weigh approximately 10 mg of **(2S,4S)-Argatroban** reference standard and dissolve in an appropriate volume of methanol to achieve a final concentration of 1 mg/mL.
- Internal Standard Stock Solution (1 mg/mL): Prepare a 1 mg/mL stock solution of the chosen internal standard (e.g., Argatroban-d5) in methanol.
- Working Solutions: Prepare a series of working solutions for calibration standards and quality controls (QCs) by serial dilution of the primary stock solution with a 50:50 mixture of methanol and water.

### Sample Preparation Protocol

- Label 1.5 mL microcentrifuge tubes for each standard, QC, and unknown plasma sample.

- To each tube, add 300  $\mu$ L of the protein precipitation solution (acetonitrile containing the internal standard at a consistent concentration).
- Add 100  $\mu$ L of the corresponding calibration standard, QC, or plasma sample to each tube.
- Vortex each tube vigorously for 30 seconds to ensure complete protein precipitation.[\[12\]](#)
- Centrifuge the tubes at 14,000 x g for 10 minutes at 4°C to pellet the precipitated proteins.  
[\[12\]](#)
- Carefully transfer 200  $\mu$ L of the clear supernatant to a 96-well plate or autosampler vials.
- The samples are now ready for injection into the LC-MS/MS system.

## LC-MS/MS Instrumental Parameters

The following table provides a validated set of starting parameters. These may require optimization based on the specific instrumentation used.

Parameter	Condition
LC System	UPLC/HPLC System
Column	C18, 1.7-2.1 $\mu$ m, 50-100 mm length
Mobile Phase A	0.1% Formic Acid in Water
Mobile Phase B	0.1% Formic Acid in Methanol/Acetonitrile
Flow Rate	0.3 - 0.5 mL/min
Gradient	Typical start at 5-10% B, ramp to 95% B, re-equilibrate
Injection Volume	5 - 10 $\mu$ L
Column Temperature	40°C
MS System	Triple Quadrupole Mass Spectrometer
Ionization Mode	Electrospray Ionization (ESI), Positive
MRM Transitions	To be optimized for Argatroban and IS
Source Temp.	Instrument dependent (e.g., 500°C)
Gas Flows	Optimize for specific instrument
Collision Energy	Optimize for each MRM transition

## Method Validation

A full validation of this bioanalytical method should be performed in accordance with regulatory guidelines from bodies like the EMA or FDA, which are largely harmonized under the ICH M10 guideline.<sup>[4][17][18][19]</sup>

## Validation Parameters and Acceptance Criteria

Parameter	Objective	Acceptance Criteria (based on EMA/ICH M10)[4][20]
Selectivity	Assess interference from endogenous matrix components.	No significant interfering peaks at the retention time of the analyte and IS.
Linearity & Range	Establish the relationship between concentration and response.	Calibration curve with at least 6 non-zero standards; correlation coefficient ( $r^2$ ) $\geq$ 0.99.
Lower Limit of Quantification (LLOQ)	Determine the lowest concentration that can be reliably quantified.	Analyte response is at least 5 times the blank response; Accuracy within $\pm 20\%$ , Precision $\leq 20\%$ CV.
Accuracy & Precision	Assess the closeness of measured values to the true value and the variability of the measurements.	For QCs (Low, Mid, High), accuracy within $\pm 15\%$ of nominal, precision $\leq 15\%$ CV. For LLOQ, accuracy within $\pm 20\%$ , precision $\leq 20\%$ CV.
Matrix Effect	Evaluate the effect of matrix components on analyte ionization.	The coefficient of variation of the IS-normalized matrix factor should be $\leq 15\%$ .
Recovery	Determine the efficiency of the extraction process.	Should be consistent, precise, and reproducible.
Stability	Evaluate analyte stability under various conditions (freeze-thaw, short-term, long-term, post-preparative).	Mean concentration at each stability QC level should be within $\pm 15\%$ of the nominal concentration.

## Sample Validation Results (Example Data)

The following table presents example validation data that would be expected from a successful method validation.

Parameter	LLOQ (3 ng/mL)	Low QC (10 ng/mL)	Mid QC (100 ng/mL)	High QC (2500 ng/mL)
Intra-day Precision (%CV)	< 12%	< 10%	< 8%	< 8%
Inter-day Precision (%CV)	< 12%	< 10%	< 9%	< 9%
Accuracy (% Bias)	± 10%	± 8%	± 6%	± 7%

Data adapted from published literature demonstrating typical performance. [8][9]

## Conclusion

The LC-MS/MS method detailed in this application note provides a sensitive, selective, and reliable approach for the quantification of **(2S,4S)-Argatroban** in human plasma. The simple protein precipitation sample preparation protocol allows for high-throughput analysis, making it suitable for both clinical research and therapeutic drug monitoring. The method's performance, when validated according to international guidelines, ensures the generation of high-quality data for critical decision-making in drug development and patient care.

## References

- Development of a fast and simple liquid chromatography–tandem mass spectrometry method for the quantitation of argatroban in patient plasma samples. BioKB. Available at: [\[Link\]](#)
- Development of a fast and simple liquid chromatography-tandem mass spectrometry method for the quantitation of argatroban in patient plasma samples. PubMed. Available at: [\[Link\]](#)
- Monitoring of argatroban in critically ill patients: a prospective study comparing aPTT, point-of-care viscoelastic testing with ecarin clotting time and dTT to mass spectrometry. Anesthesia Experts. Available at: [\[Link\]](#)
- ISOLATING DRUGS FROM BIOLOGICAL FLUIDS - USING "SOLVENT FIRST" PROTEIN PRECIPITATION. Norlab. Available at: [\[Link\]](#)

- A multi-analyte LC-MS/MS method for the determination of 57 pharmaceuticals and illicit drugs in plasma, and its application to poisoning cases. PubMed. Available at: [\[Link\]](#)
- Internal Standard Responses in LC-MS/MS Based Bioanalysis: Friend or Foe?. BioPharma Services. Available at: [\[Link\]](#)
- Simultaneous monitoring of argatroban and its major metabolite using an HPLC method: potential clinical applications. PubMed. Available at: [\[Link\]](#)
- Argatroban - Critical Care Medication. YouTube. Available at: [\[Link\]](#)
- Quantitation of argatroban in plasma using liquid chromatography electrospray tandem mass spectrometry (UPLC-ESI-MS/MS). PubMed. Available at: [\[Link\]](#)
- Argatroban | C23H36N6O5S. PubChem. Available at: [\[Link\]](#)
- ARGATROBAN. London Health Sciences Centre. Available at: [\[Link\]](#)
- Protein Precipitation for Biological Fluid Samples Using Agilent Captiva EMR—Lipid 96-Well Plates. Agilent. Available at: [\[Link\]](#)
- Argatroban is stable in citrated whole blood for 24 hours. PubMed. Available at: [\[Link\]](#)
- Bioanalytical method validation - Scientific guideline. European Medicines Agency. Available at: [\[Link\]](#)
- A New HPLC Method for Argatroban Intermediate and its Related Substance. ResearchGate. Available at: [\[Link\]](#)
- Pharmacology of argatroban. PubMed. Available at: [\[Link\]](#)
- A New Solid-Phase Extraction Method for Determination of Pantoprazole in Human Plasma Using High-Performance Liquid Chromatography. PMC - NIH. Available at: [\[Link\]](#)
- What are the Best Practices of LC-MS/MS Internal Standards?. NorthEast BioLab. Available at: [\[Link\]](#)

- Optimisation of Solid-Phase Extraction and LC-MS/MS Analysis of Six Breast Cancer Drugs in Patient Plasma Samples. MDPI. Available at: [\[Link\]](#)
- Dilution Argatroban. GlobalRPH. Available at: [\[Link\]](#)
- Argatroban. StatPearls - NCBI Bookshelf. Available at: [\[Link\]](#)
- Guideline Bioanalytical method validation. European Medicines Agency. Available at: [\[Link\]](#)
- Selection of internal standards for accurate quantification of complex lipid species in biological extracts by electrospray ionization mass spectrometry – What, how and why?. PMC - NIH. Available at: [\[Link\]](#)
- Reversible Crystallization of Argatroban after Subcutaneous Application in Pigs. PMC - NIH. Available at: [\[Link\]](#)
- What is the mechanism of Argatroban?. Patsnap Synapse. Available at: [\[Link\]](#)
- Argatroban Injection Label. accessdata.fda.gov. Available at: [\[Link\]](#)
- NDA 203049Orig1s000. accessdata.fda.gov. Available at: [\[Link\]](#)
- Practice of solid-phase extraction and protein precipitation in the 96-well format combined with high-performance liquid chromatography-ultraviolet detection for the analysis of drugs in plasma and brain. ResearchGate. Available at: [\[Link\]](#)
- Bioanalytical method validation: new FDA guidance vs. EMA guideline. Better or worse?. ScienceDirect. Available at: [\[Link\]](#)
- Internal Standard Selection. Reddit. Available at: [\[Link\]](#)
- Bioanalytical method validation and study sample analysis m10. ICH. Available at: [\[Link\]](#)
- Solid phase extraction – Knowledge and References. Taylor & Francis. Available at: [\[Link\]](#)
- Bioanalytical method validation: new FDA guidance vs. EMA guideline. Better or worse?. PubMed. Available at: [\[Link\]](#)

- Argatroban and its structural elements (A-C) susceptible to chemical changes.

ResearchGate. Available at: [\[Link\]](#)

### Need Custom Synthesis?

BenchChem offers custom synthesis for rare earth carbides and specific isotopic labeling.

Email: [info@benchchem.com](mailto:info@benchchem.com) or [Request Quote Online](#).

## Sources

- 1. Argatroban is stable in citrated whole blood for 24 hours - PubMed [\[pubmed.ncbi.nlm.nih.gov\]](https://pubmed.ncbi.nlm.nih.gov)
- 2. Pharmacology of argatroban - PubMed [\[pubmed.ncbi.nlm.nih.gov\]](https://pubmed.ncbi.nlm.nih.gov)
- 3. What is the mechanism of Argatroban? [\[synapse.patsnap.com\]](https://synapse.patsnap.com)
- 4. [database.ich.org](https://database.ich.org) [\[database.ich.org\]](https://database.ich.org)
- 5. [accessdata.fda.gov](https://accessdata.fda.gov) [\[accessdata.fda.gov\]](https://accessdata.fda.gov)
- 6. [medkoo.com](https://medkoo.com) [\[medkoo.com\]](https://medkoo.com)
- 7. [anesthesiaexperts.com](https://anesthesiaexperts.com) [\[anesthesiaexperts.com\]](https://anesthesiaexperts.com)
- 8. BioKB - Publication [\[biokb.lcsb.uni.lu\]](https://biokb.lcsb.uni.lu)
- 9. Development of a fast and simple liquid chromatography-tandem mass spectrometry method for the quantitation of argatroban in patient plasma samples - PubMed [\[pubmed.ncbi.nlm.nih.gov\]](https://pubmed.ncbi.nlm.nih.gov)
- 10. [norlab.com](https://norlab.com) [\[norlab.com\]](https://norlab.com)
- 11. [agilent.com](https://agilent.com) [\[agilent.com\]](https://agilent.com)
- 12. [benchchem.com](https://benchchem.com) [\[benchchem.com\]](https://benchchem.com)
- 13. [nebiolab.com](https://nebiolab.com) [\[nebiolab.com\]](https://nebiolab.com)
- 14. [biopharmaservices.com](https://biopharmaservices.com) [\[biopharmaservices.com\]](https://biopharmaservices.com)
- 15. Internal Standards in LC–MS Bioanalysis: Which, When, and How - WuXi AppTec DMPK [\[dmpk.service.wuxiapptec.com\]](https://dmpk.service.wuxiapptec.com)
- 16. Quantitation of argatroban in plasma using liquid chromatography electrospray tandem mass spectrometry (UPLC-ESI-MS/MS) - PubMed [\[pubmed.ncbi.nlm.nih.gov\]](https://pubmed.ncbi.nlm.nih.gov)

- [17. Bioanalytical method validation - Scientific guideline | European Medicines Agency \(EMA\) \[ema.europa.eu\]](#)
- [18. elearning.unite.it \[elearning.unite.it\]](#)
- [19. Bioanalytical method validation: new FDA guidance vs. EMA guideline. Better or worse? - PubMed \[pubmed.ncbi.nlm.nih.gov\]](#)
- [20. ema.europa.eu \[ema.europa.eu\]](#)
- To cite this document: BenchChem. [Developing LC-MS/MS methods for quantifying (2S,4S)-Argatroban in plasma]. BenchChem, [2026]. [Online PDF]. Available at: [<https://www.benchchem.com/product/b601580/docs#developing-lc-ms-ms-methods-for-quantifying-2s-4s-argatroban-in-plasma>]

---

### Disclaimer & Data Validity:

The information provided in this document is for Research Use Only (RUO) and is strictly not intended for diagnostic or therapeutic procedures. While BenchChem strives to provide accurate protocols, we make no warranties, express or implied, regarding the fitness of this product for every specific experimental setup.

**Technical Support:** The protocols provided are for reference purposes. Unsure if this reagent suits your experiment?

**Need Industrial/Bulk Grade?** [Request Custom Synthesis Quote](#)

## BenchChem

Our mission is to be the trusted global source of essential and advanced chemicals, empowering scientists and researchers to drive progress in science and industry.

### Contact

Address: 3281 E Guasti Rd  
Ontario, CA 91761, United States  
Phone: (601) 213-4426  
Email: [info@benchchem.com](mailto:info@benchchem.com)

Contact our Ph.D. Support Team for a compatibility check