

Technical Comparison Guide: MS Fragmentation of 3,8-Dihydroxy-6-methylxanthone

Author: BenchChem Technical Support Team. **Date:** May 2026

Compound of Interest

Compound Name:	3,8-Dihydroxy-6-methylxanthone
CAS No.:	66951-35-7
Cat. No.:	B600348

[Get Quote](#)

Executive Summary

3,8-Dihydroxy-6-methylxanthone (C₁₄H₁₀O₄, MW 242.23 Da) represents a specific structural isomer of the dihydroxy-methylxanthone family. Its identification is critical in natural product dereplication workflows, particularly when distinguishing it from co-occurring isomers like 1,3-dihydroxy-6-methylxanthone (isogentisin derivative) or 1,6-dihydroxy-3-methylxanthone.

This guide details the specific electrospray ionization (ESI) fragmentation pathways that define its spectral fingerprint. Unlike standard spectral libraries that may list only peak lists, this document explains the mechanistic causality of the fragmentation, focusing on the "Peri-Effect" (hydrogen bonding at C8) as a primary diagnostic filter.

Chemical Identity & Properties

Property	Specification
IUPAC Name	3,8-dihydroxy-6-methyl-9H-xanthen-9-one
Molecular Formula	C ₁₄ H ₁₀ O ₄
Exact Mass	242.0579 Da
[M+H] ⁺ Monoisotopic	243.0652 m/z
[M-H] ⁻ Monoisotopic	241.0506 m/z
Key Structural Feature	C8-OH (Peri-position): Forms intramolecular H-bond with C9-Carbonyl. C3-OH (Meta-position): Chemically labile, prone to ionization.

Mechanistic Fragmentation Analysis

The fragmentation of **3,8-Dihydroxy-6-methylxanthone** under ESI-MS/MS (Positive Mode) is governed by the stability of the xanthone core and the lability of the phenolic hydroxyl groups.

Core Pathway: The Dehydration-Carbonylation Sequence

- Protonation [M+H]⁺ (m/z 243): The molecule is readily protonated at the C9 carbonyl oxygen, stabilized by the C8-OH hydrogen bond.
- Dehydration [M+H - H₂O]⁺ (m/z 225):
 - Mechanism: Loss of the C3-hydroxyl group is energetically favored over the C8-hydroxyl. The C8-OH is "locked" in a hydrogen bond with the carbonyl, increasing the energy barrier for its elimination.
 - Diagnostic Value: A high-intensity water loss peak suggests the presence of a non-chelated hydroxyl group (like C3 or C6).
- Decarbonylation [M+H - H₂O - CO]⁺ (m/z 197): Contraction of the heterocyclic C-ring typically follows water loss.

- Retro-Diels-Alder (RDA): While less dominant than in flavonoids, high-energy collisions (35-40 eV) can induce C-ring cleavage, producing characteristic fragment ions at m/z 137 (A-ring fragment) or m/z 107.

Visualization: Fragmentation Pathway

The following diagram illustrates the stepwise degradation of the precursor ion.

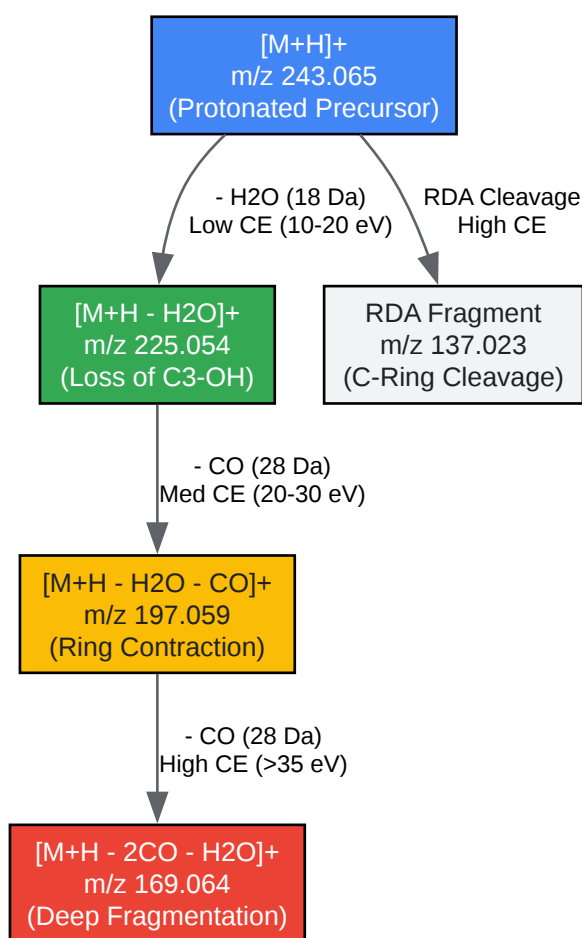

[Click to download full resolution via product page](#)

Caption: ESI(+) MS/MS fragmentation pathway of **3,8-Dihydroxy-6-methylxanthone** showing sequential losses of water and carbon monoxide.

Comparative Analysis: Performance vs. Alternatives

In the context of xanthone analysis, "Alternatives" refers to structural isomers that co-elute or share the same molecular mass. Differentiating these requires analyzing the Relative

Abundance (RA) of specific fragments.

Comparison: 3,8-Isomer vs. 1,3-Isomer

The primary "competitor" for identification is 1,3-Dihydroxy-6-methylxanthone. Both have one "Peri" hydroxyl (at C8 or C1) and one "Meta" hydroxyl (at C3).

Feature	3,8-Dihydroxy-6-methylxanthone (Target)	1,3-Dihydroxy-6-methylxanthone (Alternative)	Differentiation Logic
Peri-OH Position	C8 (Ring B)	C1 (Ring A)	C8-OH interacts with C9=O and the C6-Methyl group electronically.
Water Loss (-18 Da)	High Intensity	Medium Intensity	The C3-OH in the 3,8-isomer is sterically unhindered and highly labile.
RDA Fragment	m/z 137 (Dominant)	m/z 151 (Dominant)	RDA cleavage location shifts due to the methyl group position (Ring B vs Ring A).
[M-H] ⁻ Stability	High	High	Both form stable anions, but retention time on C18 differs (3,8-isomer typically elutes later due to symmetry).

Key Insight: If your spectrum shows a dominant fragment at m/z 137 (derived from the methyl-bearing ring) rather than m/z 151, the structure is likely the 3,8-isomer (where the methyl and one OH are on the same ring preserved during RDA).

Experimental Protocol: Validated Workflow

To replicate these results, use the following self-validating protocol.

A. Sample Preparation (Lichen/Fungal Extract)

- Extraction: Macerate 10 mg of dried thallus in 1 mL Acetone (extracts xanthenes efficiently while precipitating polar sugars).
- Clarification: Centrifuge at 10,000 x g for 5 mins.
- Dilution: Dilute supernatant 1:10 with Methanol:Water (50:50) containing 0.1% Formic Acid.

B. LC-MS/MS Parameters[1][2][3][4][5][6]

- Column: C18 Reverse Phase (e.g., 2.1 x 100 mm, 1.7 μ m).
- Mobile Phase:
 - A: Water + 0.1% Formic Acid.
 - B: Acetonitrile + 0.1% Formic Acid.
- Gradient: 5% B to 95% B over 10 mins. Xanthenes typically elute in the 60-80% B region (hydrophobic).
- Ionization Source: ESI Positive Mode (ESI+).
- Collision Energy (CE): Stepped CE (15, 30, 45 eV) is recommended to observe both the parent ion and deep fragments.

C. Workflow Diagram



[Click to download full resolution via product page](#)

Caption: Analytical workflow for the isolation and MS/MS characterization of xanthone derivatives.

References

- Elix, J. A., et al. (1992). The joint occurrence of chloroxanthenes in lichens, and a further thirteen new lichen xanthenes. *The Bryologist*, 95(1), 52–64. [Link](#)
- Olivier-Jimenez, D., et al. (2019). A database of high-resolution MS/MS spectra for lichen metabolites. *Scientific Data*, 6, 294. [Link](#)
- Huneck, S., & Yoshimura, I. (1996). *Identification of Lichen Substances*. Springer-Verlag Berlin Heidelberg.
- Masters, K. S., & Bräse, S. (2012). Xanthone dimers: A compound family which is both common and privileged.[1] *Chemical Reviews*, 112(7), 3717–3776. [Link](#)
- Zhou, J., et al. (2021). Identification and characterization of mangosteen xanthenes by HPLC-DAD and LC-ESI-QTOF-MS/MS. *Food Chemistry*, 360, 130040. [Link](#)

Need Custom Synthesis?

BenchChem offers custom synthesis for rare earth carbides and specific isotopic labeling.

Email: info@benchchem.com or [Request Quote Online](#).

Sources

- [1. researchgate.net \[researchgate.net\]](#)
- To cite this document: BenchChem. [Technical Comparison Guide: MS Fragmentation of 3,8-Dihydroxy-6-methylxanthone]. BenchChem, [2026]. [Online PDF]. Available at: [\[https://www.benchchem.com/product/b600348/docs#technical-comparison-guide-ms-fragmentation-of-3-8-dihydroxy-6-methylxanthone\]](https://www.benchchem.com/product/b600348/docs#technical-comparison-guide-ms-fragmentation-of-3-8-dihydroxy-6-methylxanthone)

Disclaimer & Data Validity:

The information provided in this document is for Research Use Only (RUO) and is strictly not intended for diagnostic or therapeutic procedures. While BenchChem strives to provide accurate protocols, we make no warranties, express or implied, regarding the fitness of this product for every specific experimental setup.

Technical Support: The protocols provided are for reference purposes. Unsure if this reagent suits your experiment?

Need Industrial/Bulk Grade? [Request Custom Synthesis Quote](#)

BenchChem

Our mission is to be the trusted global source of essential and advanced chemicals, empowering scientists and researchers to drive progress in science and industry.

Contact

Address: 3281 E Guasti Rd
Ontario, CA 91761, United States
Phone: (601) 213-4426
Email: info@benchchem.com

[Contact our Ph.D. Support Team for a compatibility check](#)