

Quantitative Benchmarks: Conventional vs. Microwave Synthesis

Author: BenchChem Technical Support Team. **Date:** April 2026

Compound of Interest

Compound Name: 4-(4-methyl-1-piperazinyl)-2-phenylquinazoline

CAS No.: 143871-26-5

Cat. No.: B5994473

[Get Quote](#)

Before optimizing your protocol, it is critical to establish baseline expectations. The table below summarizes the quantitative advantages of transitioning a standard Niementowski quinazoline synthesis to a microwave-assisted platform[1][2].

Parameter	Conventional Thermal Heating	Microwave-Assisted Heating
Reaction Time	6 – 12 hours	10 – 20 minutes
Operating Temperature	130 – 150 °C	120 – 150 °C
Typical Yield	40 – 60%	80 – 95%
Crude Purity	Moderate (prone to thermal degradation)	>95% (highly selective)
Environmental (E-factor)	High (excess solvent required)	Near zero (solvent-free viable)

Standard Operating Procedure (SOP): ZnCl₂-Promoted Synthesis of Quinazolines

This self-validating protocol details the synthesis of fully aromatic quinazolines from 2-aminoarylalkanone O-phenyl oximes and aldehydes[3].

Step 1: Reagent Preparation

- Action: In a 10 mL microwave-safe quartz or thick-walled borosilicate vial, combine 2-aminoarylalkanone O-phenyl oxime (1.0 equiv) and the desired aldehyde (1.0 equiv) in 2 mL of anhydrous toluene.
- Self-Validation Checkpoint: Ensure the oxime is fully dissolved. A homogeneous solution confirms uniform dielectric heating potential; particulates will cause localized microwave scattering.

Step 2: Catalyst Addition

- Action: Add 20 mol% anhydrous ZnCl₂ to the reaction mixture. Add a magnetic stir bar and seal the vial with a Teflon-lined crimp cap.
- Self-Validation Checkpoint: The solution should remain clear or form a very fine, uniform suspension. Clumping indicates moisture contamination in the ZnCl₂, which will preferentially absorb microwaves and skew the heating profile.

Step 3: Microwave Irradiation

- Action: Place the vial in a monomode microwave synthesizer. Program the system to ramp to 150 °C over 2 minutes, holding at 150 °C for 15 minutes with dynamic power modulation (max 200 W).
- Self-Validation Checkpoint: Monitor the real-time power readout. The power should spike initially during the ramp and then drop to <40 W to maintain the target temperature. Continuous high power input indicates an endothermic side reaction or a failing vessel seal.

Step 4: Rapid Cooling & Depressurization

- Action: Allow the system's compressed air mechanism to cool the vial to $<40\text{ }^{\circ}\text{C}$.
- Self-Validation Checkpoint: The internal pressure transducer must register a drop to $<1\text{ bar}$ before the cavity unlocks, ensuring no volatile expansion occurs upon opening.

Step 5: Workup

- Action: Dilute the mixture with ethyl acetate, wash with brine, dry over MgSO_4 , and concentrate.
- Self-Validation Checkpoint: TLC or LC-MS should show complete consumption of the lower-Rf oxime precursor, confirming the successful N–O bond scission and cyclization.

Mechanistic Workflow Diagram

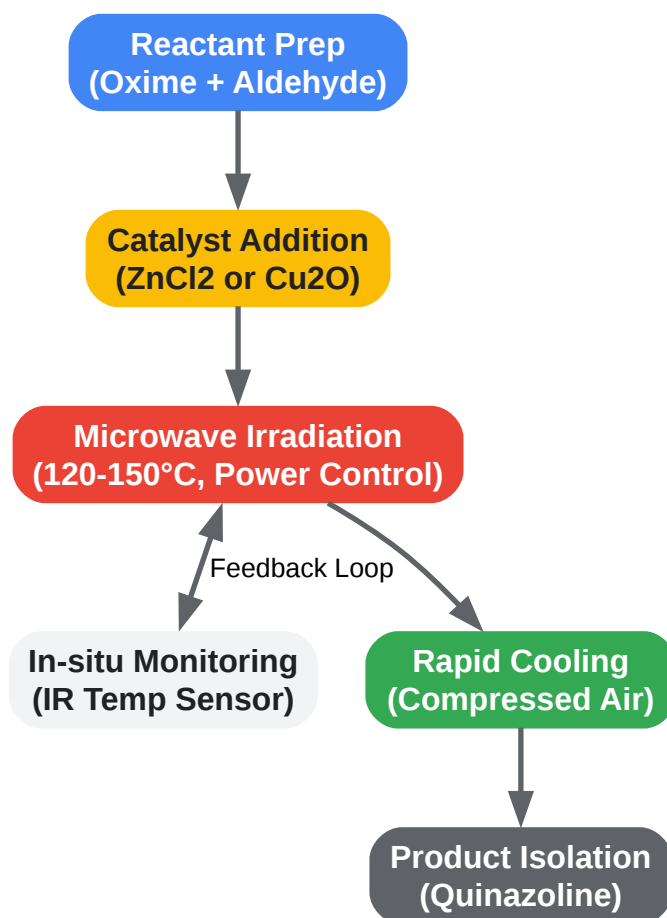

[Click to download full resolution via product page](#)

Workflow of microwave-assisted quinazoline synthesis with feedback-controlled irradiation.

Troubleshooting Guide

Issue 1: Incomplete Aromatization (Formation of Dihydroquinazolines)

- Symptom: LC-MS analysis shows a dominant mass corresponding to the dihydroquinazoline intermediate rather than the fully aromatic quinazoline.
- Causality: The initial condensation of 2-aminoarylalkanone O-phenyl oximes with aldehydes rapidly yields dihydroquinazolines under microwave heating. However, the subsequent oxidative aromatization requires a driving force to facilitate N–O bond scission and elimination.
- Solution: Ensure the addition of a Lewis acid co-catalyst like ZnCl_2 . ZnCl_2 coordinates with the intermediate, lowering the activation energy for aromatization and shifting the equilibrium entirely toward the fully aromatic quinazoline[3].

Issue 2: Charring and Thermal Degradation

- Symptom: The reaction mixture turns black and chars within the first 5 minutes of irradiation, resulting in near-zero yield.
- Causality: Microwave heating relies on the dielectric loss tangent ($\tan \delta$) of the reaction mixture. Highly polar solvents or ionic liquids couple intensely with the microwave field. If the synthesizer is set to a high fixed power without temperature feedback, localized superheating ("hot spots") causes rapid thermal degradation.
- Solution: Switch your instrument from "Power-Control" to "Temperature-Control" mode, utilizing an IR or fiber-optic temperature sensor to dynamically modulate wattage. Alternatively, use a solvent with a lower dielectric constant (e.g., toluene) to moderate the heating rate[3].

Issue 3: Poor Regioselectivity in Multi-Component Reactions

- Symptom: Attempting a one-pot, three-component synthesis of quinazolinones yields multiple off-target amides and poor recovery of the desired product.

- Causality: Multi-component reactions (e.g., isatoic anhydride, aldehydes, and anilines) are susceptible to competing nucleophilic attacks if the electrophilic centers are not differentially activated.
- Solution: Utilize a targeted catalyst such as Cu₂O nanocubes. These catalysts selectively activate the carbonyl group of the isatoic anhydride, orchestrating a sequential ring-opening and cyclocondensation pathway that minimizes side reactions[4].

Frequently Asked Questions (FAQs)

Q: Can I scale up my 2 mL optimized microwave protocol directly to a 50 mL batch vessel? A: No. The penetration depth of microwave radiation at the standard 2.45 GHz frequency is physically limited (typically 1–2 cm, depending on the medium's dielectric properties). In a larger batch vessel, the core of the reaction mixture relies on standard convective heat transfer rather than direct dielectric heating, negating the "microwave effect." To scale up successfully, transition from a monomode batch reactor to a continuous-flow microwave system, which maintains the optimal narrow irradiation path length[5].

Q: What is the mechanistic advantage of using solvent-free conditions for the Niementowski quinazoline synthesis? A: The traditional Niementowski reaction (anthranilic acid + formamide) requires harsh, prolonged heating. Under solvent-free (neat) microwave conditions, the polar reactants themselves—or an acidic solid support like Montmorillonite K-10—act as the primary microwave absorbers. This concentrates the thermal energy directly at the reaction sites, drastically accelerating the o-amidine intermediate formation and subsequent cyclization, reducing reaction times from hours to minutes while driving the E-factor to near zero[1][6].

Need Custom Synthesis?

BenchChem offers custom synthesis for rare earth carbides and specific isotopic labeling.

Email: info@benchchem.com or [Request Quote Online](#).

Sources

- [1. tandfonline.com](http://1.tandfonline.com) [tandfonline.com]
- [2. derpharmachemica.com](http://2.derpharmachemica.com) [derpharmachemica.com]

- [3. pubs.acs.org \[pubs.acs.org\]](https://pubs.acs.org)
- [4. Recent Advances in Microwave-Assisted Copper-Catalyzed Cross-Coupling Reactions \[mdpi.com\]](https://mdpi.com)
- [5. researchgate.net \[researchgate.net\]](https://researchgate.net)
- [6. Microwave-Assisted Synthesis of Quinazolines and Quinazolinones: An Overview - PMC \[pmc.ncbi.nlm.nih.gov\]](https://pubmed.ncbi.nlm.nih.gov)
- To cite this document: BenchChem. [Quantitative Benchmarks: Conventional vs. Microwave Synthesis]. BenchChem, [2026]. [Online PDF]. Available at: [\[https://www.benchchem.com/product/b5994473/docs#quantitative-benchmarks-conventional-vs-microwave-synthesis\]](https://www.benchchem.com/product/b5994473/docs#quantitative-benchmarks-conventional-vs-microwave-synthesis)

Disclaimer & Data Validity:

The information provided in this document is for Research Use Only (RUO) and is strictly not intended for diagnostic or therapeutic procedures. While BenchChem strives to provide accurate protocols, we make no warranties, express or implied, regarding the fitness of this product for every specific experimental setup.

Technical Support: The protocols provided are for reference purposes. Unsure if this reagent suits your experiment?

Need Industrial/Bulk Grade? [Request Custom Synthesis Quote](#)

BenchChem

Our mission is to be the trusted global source of essential and advanced chemicals, empowering scientists and researchers to drive progress in science and industry.

Contact

Address: 3281 E Guasti Rd
Ontario, CA 91761, United States
Phone: (601) 213-4426
Email: info@benchchem.com

Contact our Ph.D. Support Team for a compatibility check