

Technical Support Center: Optimization of N-Substituted Benzamide Synthesis

Author: BenchChem Technical Support Team. **Date:** April 2026

Compound of Interest

Compound Name: *2-Amino-3-chloro-N-methylbenzamide*

CAS No.: *18343-42-5*

Cat. No.: *B599409*

[Get Quote](#)

Welcome to the Technical Support Center for N-Substituted Benzamide Synthesis. This guide is designed for researchers, scientists, and drug development professionals to provide in-depth technical guidance, troubleshooting strategies, and answers to frequently asked questions. Our goal is to move beyond simple protocols and offer a deeper understanding of the chemical principles at play, enabling you to optimize your reaction conditions for higher yields, purity, and reproducibility.

Section 1: Foundational Principles of Benzamide Synthesis

The synthesis of N-substituted benzamides is a cornerstone of medicinal chemistry, with the amide bond being a critical functional group in a vast array of pharmaceuticals. The two primary strategies for constructing this bond involve the reaction of a primary or secondary amine with either a benzoyl chloride derivative or a benzoic acid that has been activated with a coupling reagent.

The Schotten-Baumann Reaction: A Classic Approach

The reaction of a primary or secondary amine with a benzoyl chloride, typically in the presence of a base, is known as the Schotten-Baumann reaction.[1] This method is often high-yielding and rapid due to the high reactivity of the acyl chloride.[2]

Mechanism of the Schotten-Baumann Reaction:

The reaction proceeds via a nucleophilic acyl substitution mechanism. The lone pair of electrons on the amine's nitrogen atom attacks the electrophilic carbonyl carbon of the benzoyl chloride. This forms a tetrahedral intermediate, which then collapses, expelling the chloride ion as a leaving group. A base is crucial to neutralize the hydrochloric acid byproduct, which would otherwise protonate the starting amine, rendering it non-nucleophilic and halting the reaction.[3][4][5]



FULL PROTOCOL TRUNCATED

To view exact molar ratios, purification steps, and HRP optimization data, please view the interactive version.

[Unlock Full Protocol on Website](#)

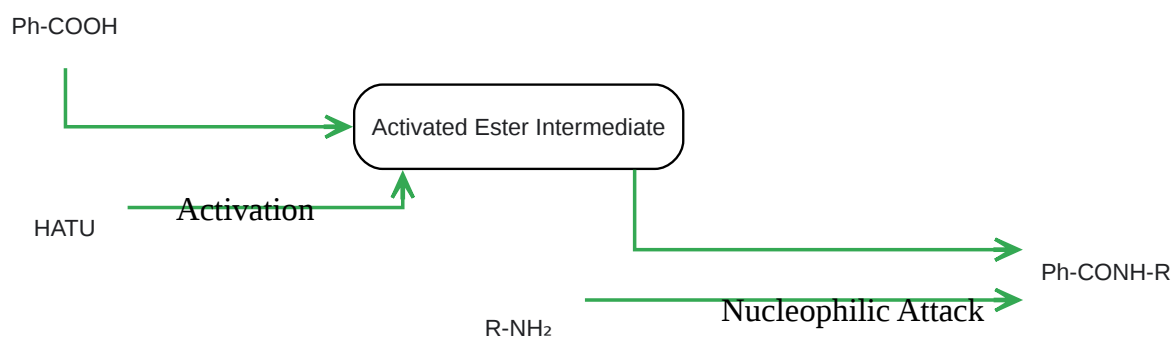

[Click to download full resolution via product page](#)

Caption: General mechanism of HATU-mediated amide coupling.

Section 2: Troubleshooting Guide

This section addresses common issues encountered during the synthesis of N-substituted benzamides, providing explanations for the underlying causes and actionable solutions.

Q1: My reaction yield is low. What are the common culprits?

A1: Low yields can stem from several factors, often related to the reactivity of your starting materials or the reaction conditions.

- Incomplete Reaction:
 - Causality: The reaction may not have reached completion due to insufficient reaction time, low temperature, or poor mixing, especially in biphasic systems like the Schotten-Baumann reaction. [6] * Solution:
 - Monitor the reaction progress using Thin Layer Chromatography (TLC) or Liquid Chromatography-Mass Spectrometry (LC-MS).

- If the reaction has stalled, consider increasing the temperature or extending the reaction time.
- For biphasic reactions, ensure vigorous stirring to maximize the interfacial area between the aqueous and organic layers.
- Hydrolysis of Benzoyl Chloride:
 - Causality: Benzoyl chloride is highly reactive towards water. Any moisture in your solvent or on your glassware will lead to the formation of benzoic acid, consuming your starting material. [4] * Solution:
 - Use anhydrous solvents and ensure all glassware is thoroughly oven-dried.
 - Run the reaction under an inert atmosphere (e.g., nitrogen or argon).
 - Use a fresh bottle of benzoyl chloride or distill it before use.
- Protonation of the Amine:
 - Causality: In the Schotten-Baumann reaction, the HCl byproduct will protonate the amine starting material, rendering it non-nucleophilic. [4] * Solution:
 - Ensure a sufficient amount of base (at least one equivalent, often a slight excess) is used to neutralize the HCl as it is formed.

Q2: I'm observing a significant amount of an unexpected byproduct. How do I identify and prevent it?

A2: Byproduct formation is a common challenge. Identifying the byproduct is the first step to mitigating its formation.

- Unreacted Benzoic Acid:
 - Identification: Benzoic acid can be easily identified by its solubility in a mild aqueous base like sodium bicarbonate, whereas most N-substituted benzamides are not. [6] *
 - Prevention: As discussed in Q1, prevent the hydrolysis of benzoyl chloride by ensuring anhydrous conditions.

- Removal: During the workup, wash the organic layer containing your product with a saturated solution of sodium bicarbonate. The benzoic acid will be converted to sodium benzoate and move into the aqueous layer. [7]
- N,N-Dibenzoylation of Primary Amines:
 - Causality: This occurs when a primary amine reacts with two molecules of benzoyl chloride. It is more likely to happen if there is a high local concentration of benzoyl chloride relative to the amine. [6] * Prevention:
 - Add the benzoyl chloride dropwise to a solution of the amine, rather than the other way around.
 - Ensure vigorous stirring to quickly disperse the benzoyl chloride.
 - Using a slight excess of the amine can also help minimize this side reaction. [6]
- Byproducts from Coupling Reagents (e.g., DCU from DCC):
 - Causality: Carbodiimide coupling reagents like DCC form urea byproducts. Dicyclohexylurea (DCU) is notoriously insoluble in many common organic solvents. [8] * Removal:
 - Most of the DCU will precipitate out of the reaction mixture (e.g., in dichloromethane) and can be removed by filtration. [9] * If some DCU remains in the crude product, it can often be removed by recrystallization from a suitable solvent.

Q3: My product is an oil and will not crystallize. What should I do?

A3: "Oiling out" is a common purification problem that occurs when the compound separates from the solution as a liquid rather than a solid.

- Causality: This can happen if the solution is too concentrated, cooled too quickly, or if impurities are preventing crystal lattice formation.
- Solutions:

- Induce Crystallization: Try scratching the inside of the flask at the solvent line with a glass rod to create nucleation sites. Adding a seed crystal of the pure compound, if available, is also highly effective.
- Slow Down Cooling: Reheat the solution to redissolve the oil, then allow it to cool very slowly to room temperature before placing it in an ice bath or refrigerator.
- Adjust Solvent System: You may have too much of a "good" solvent. Try adding a "poor" solvent dropwise until the solution becomes slightly cloudy (the point of saturation), then allow it to cool slowly. Alternatively, if you have too little solvent, the concentration may be too high. Try adding a small amount more of the "good" solvent.

Section 3: Experimental Protocols

The following are generalized, step-by-step protocols for the two main synthetic routes. These should be adapted based on the specific properties of your substrates.

Protocol 1: Synthesis via Acyl Chloride (Schotten-Baumann Conditions)

Materials:

- Substituted Benzoyl Chloride (1.0 eq)
- Primary or Secondary Amine (1.0-1.2 eq)
- Base (e.g., Triethylamine, DIPEA, or aqueous NaOH) (1.1-2.0 eq)
- Anhydrous Solvent (e.g., Dichloromethane (DCM), Tetrahydrofuran (THF))
- Deionized Water
- Saturated Aqueous Sodium Bicarbonate (NaHCO_3)
- Brine
- Anhydrous Magnesium Sulfate (MgSO_4) or Sodium Sulfate (Na_2SO_4)

Procedure:

- **Reaction Setup:** In a clean, dry round-bottom flask under an inert atmosphere, dissolve the amine (1.0 eq) and an organic base like triethylamine (1.1-1.5 eq) in the chosen anhydrous solvent.
- **Cooling:** Cool the reaction mixture to 0 °C using an ice bath.
- **Addition of Benzoyl Chloride:** Dissolve the benzoyl chloride (1.0 eq) in a minimal amount of anhydrous solvent and add it dropwise to the cooled amine solution over 10-15 minutes.
- **Reaction:** Allow the reaction mixture to slowly warm to room temperature and stir for 1-16 hours. Monitor the reaction progress by TLC or LC-MS.
- **Quenching and Work-up:** Once the reaction is complete, quench by adding deionized water. Transfer the mixture to a separatory funnel. Wash the organic layer sequentially with saturated aqueous NaHCO₃ and brine.
- **Isolation:** Dry the organic layer over anhydrous MgSO₄ or Na₂SO₄, filter, and concentrate under reduced pressure to yield the crude benzamide.
- **Purification:** Purify the crude product by recrystallization or column chromatography.

**FULL PROTOCOL TRUNCATED**

To view exact molar ratios, purification steps, and HRP optimization data, please view the interactive version.

[Unlock Full Protocol on Website](#)

[Click to download full resolution via product page](#)

Need Custom Synthesis?

BenchChem offers custom synthesis for rare earth carbides and specific isotopic labeling.

Email: info@benchchem.com or [Request Quote Online](#).

Sources

- [1. Primary amines react with benzoyl chloride to give class 11 chemistry CBSE \[vedantu.com\]](#)
- [2. pdf.benchchem.com \[pdf.benchchem.com\]](#)
- [3. Primary amines react with benzoyl chloride to give: \(A\) Benzamides \(B - askITians \[askitians.com\]](#)
- [4. pdf.benchchem.com \[pdf.benchchem.com\]](#)
- [5. ncert.nic.in \[ncert.nic.in\]](#)
- [6. pdf.benchchem.com \[pdf.benchchem.com\]](#)
- [7. quora.com \[quora.com\]](#)
- [8. peptide.com \[peptide.com\]](#)
- [9. pubs.rsc.org \[pubs.rsc.org\]](#)
- To cite this document: BenchChem. [Technical Support Center: Optimization of N-Substituted Benzamide Synthesis]. BenchChem, [2026]. [Online PDF]. Available at: [\[https://www.benchchem.com/product/b599409#optimization-of-reaction-conditions-for-n-substituted-benzamide-synthesis\]](https://www.benchchem.com/product/b599409#optimization-of-reaction-conditions-for-n-substituted-benzamide-synthesis)

Disclaimer & Data Validity:

The information provided in this document is for Research Use Only (RUO) and is strictly not intended for diagnostic or therapeutic procedures. While BenchChem strives to provide accurate protocols, we make no warranties, express or implied, regarding the fitness of this product for every specific experimental setup.

Technical Support: The protocols provided are for reference purposes. Unsure if this reagent suits your experiment?

Need Industrial/Bulk Grade? [Request Custom Synthesis Quote](#)

BenchChem

Our mission is to be the trusted global source of essential and advanced chemicals, empowering scientists and researchers to drive progress in science and industry.

Contact

Address: 3281 E Guasti Rd
Ontario, CA 91761, United States
Phone: (601) 213-4426
Email: info@benchchem.com

[Contact our Ph.D. Support Team for a compatibility check](#)