

Technical Support Center: Diastereoselectivity with (S)-2-(Methoxymethyl)morpholine

Author: BenchChem Technical Support Team. **Date:** January 2026

Compound of Interest

Compound Name: (S)-2-(Methoxymethyl)morpholine hydrochloride
Cat. No.: B599894

[Get Quote](#)

Welcome to the technical support center for utilizing (S)-2-(Methoxymethyl)morpholine as a chiral auxiliary. This guide provides troubleshooting advice and frequently asked questions (FAQs) to assist researchers, scientists, and drug development professionals in optimizing the diastereoselectivity of their reactions, particularly concerning the influence of Lewis acids.

Frequently Asked Questions (FAQs)

Q1: What is the role of (S)-2-(Methoxymethyl)morpholine in asymmetric synthesis?

(S)-2-(Methoxymethyl)morpholine is a chiral auxiliary designed to control the stereochemical outcome of reactions. When temporarily attached to a prochiral substrate (e.g., forming an N-acyl derivative), its inherent chirality directs the approach of incoming reagents, leading to the preferential formation of one diastereomer over another. The methoxymethyl ether and the morpholine nitrogen can act as bidentate ligands for Lewis acids, enabling chelation-controlled stereoselection.

Q2: How do Lewis acids influence the diastereoselectivity of reactions using this auxiliary?

Lewis acids play a crucial role in enhancing diastereoselectivity by forming a rigid chelate with the chiral auxiliary and the carbonyl oxygen of the acyl group. This chelation locks the conformation of the enolate, exposing one face to electrophilic attack while sterically shielding the other. The choice and stoichiometry of the Lewis acid can significantly impact the rigidity of

this chelate and, consequently, the diastereomeric ratio of the product. Stronger chelating Lewis acids generally lead to higher diastereoselectivity.

Q3: Which Lewis acids are commonly used, and how do they compare?

Commonly employed Lewis acids for chelation control include titanium tetrachloride (TiCl_4), tin(IV) chloride (SnCl_4), zinc bromide (ZnBr_2), and magnesium bromide (MgBr_2).

- Titanium tetrachloride (TiCl_4) is a strong Lewis acid that often forms highly rigid chelates, typically resulting in high diastereoselectivity.
- Tin(IV) chloride (SnCl_4) is another effective Lewis acid that can provide excellent levels of stereocontrol.
- Magnesium and Zinc halides (MgBr_2 , ZnBr_2) are milder Lewis acids that can also promote chelation, though the degree of diastereoselectivity may vary depending on the substrate and reaction conditions.

The optimal Lewis acid must be determined empirically for each specific reaction.

Q4: What is the expected stereochemical outcome?

The stereochemical outcome is generally predicted by the formation of a five-membered chelated intermediate. The Lewis acid coordinates to the morpholine nitrogen and the methoxy oxygen, as well as the carbonyl oxygen of the N-acyl group. This arrangement forces the enolate to adopt a specific conformation, directing the electrophile to attack from the less sterically hindered face, away from the morpholine ring.

Troubleshooting Guide

Issue	Potential Cause(s)	Suggested Solution(s)
Low Diastereoselectivity	1. Incomplete chelation of the Lewis acid. 2. Use of a non-chelating or weakly coordinating Lewis acid. 3. Reaction temperature is too high, leading to a less organized transition state. 4. Steric hindrance from a bulky electrophile disrupting the chelate.	1. Increase the stoichiometry of the Lewis acid (e.g., from 1.1 to 1.5 equivalents). 2. Switch to a stronger chelating Lewis acid (e.g., from MgBr ₂ to TiCl ₄). 3. Perform the reaction at a lower temperature (e.g., -78 °C). 4. Consider using a less bulky electrophile if possible.
Low Reaction Yield	1. Incomplete enolate formation. 2. Degradation of starting material or product by the Lewis acid. 3. The reaction is too slow at the chosen temperature.	1. Ensure the use of a sufficiently strong base (e.g., LDA, LiHMDS) and anhydrous conditions. 2. Use a milder Lewis acid or reduce its stoichiometry. 3. Allow the reaction to proceed for a longer duration or slightly increase the temperature after the initial low-temperature addition.
Inconsistent Results	1. Presence of moisture, which can quench the enolate and deactivate the Lewis acid. 2. Impure reagents or solvents. 3. Inaccurate temperature control.	1. Ensure all glassware is oven-dried and reactions are performed under an inert atmosphere (e.g., Argon or Nitrogen). Use freshly distilled anhydrous solvents. 2. Purify all reagents and solvents before use. 3. Use a calibrated low-temperature thermometer or a cryostat for accurate temperature management.

Data Presentation

The following table summarizes representative quantitative data on the effect of different Lewis acids on the diastereoselective alkylation of N-propionyl-(S)-2-(methoxymethyl)morpholine with benzyl bromide.

Disclaimer: The following data is illustrative and based on established principles of diastereoselective alkylation with similar chiral auxiliaries. Actual results may vary based on specific experimental conditions.

Entry	Lewis Acid (equiv.)	Temperature (°C)	Diastereomeric Ratio (S,R : S,S)	Yield (%)
1	None	-78 to 0	60 : 40	75
2	MgBr ₂ (1.2)	-78	85 : 15	82
3	ZnBr ₂ (1.2)	-78	90 : 10	85
4	SnCl ₄ (1.2)	-78	95 : 5	88
5	TiCl ₄ (1.2)	-78	>98 : 2	92

Experimental Protocols

General Procedure for Lewis Acid-Mediated Diastereoselective Alkylation:

- **Preparation of the N-Acyl Auxiliary:** To a solution of (S)-2-(methoxymethyl)morpholine (1.0 equiv.) in anhydrous dichloromethane (DCM) at 0 °C, add triethylamine (1.2 equiv.). Slowly add the desired acyl chloride (1.1 equiv.) and allow the reaction to warm to room temperature and stir for 4 hours. Quench the reaction with saturated aqueous NH₄Cl, extract with DCM, dry the organic layer over Na₂SO₄, and concentrate under reduced pressure. Purify the crude product by flash column chromatography.
- **Enolate Formation and Alkylation:** To a solution of the N-acyl-(S)-2-(methoxymethyl)morpholine (1.0 equiv.) in anhydrous THF (0.1 M) at -78 °C under an argon atmosphere, add a solution of lithium diisopropylamide (LDA) (1.1 equiv. in THF) dropwise. Stir the resulting solution for 30 minutes at -78 °C.

- **Lewis Acid Addition and Chelation:** To the enolate solution at $-78\text{ }^{\circ}\text{C}$, add the selected Lewis acid (1.2 equiv., e.g., a 1.0 M solution of TiCl_4 in DCM) dropwise. Stir the mixture for 1 hour at $-78\text{ }^{\circ}\text{C}$ to allow for complete chelation.
- **Electrophilic Quench:** Add the electrophile (e.g., benzyl bromide, 1.2 equiv.) dropwise to the reaction mixture at $-78\text{ }^{\circ}\text{C}$. Stir for 4-6 hours at this temperature.
- **Workup:** Quench the reaction by adding a saturated aqueous solution of NH_4Cl . Allow the mixture to warm to room temperature and extract with ethyl acetate. Wash the combined organic layers with brine, dry over anhydrous Na_2SO_4 , and concentrate in vacuo.
- **Analysis:** Determine the diastereomeric ratio of the crude product by ^1H NMR spectroscopy or chiral HPLC analysis. Purify the product by flash column chromatography.

Mandatory Visualization

Below are diagrams illustrating the key concepts and workflows described in this guide.

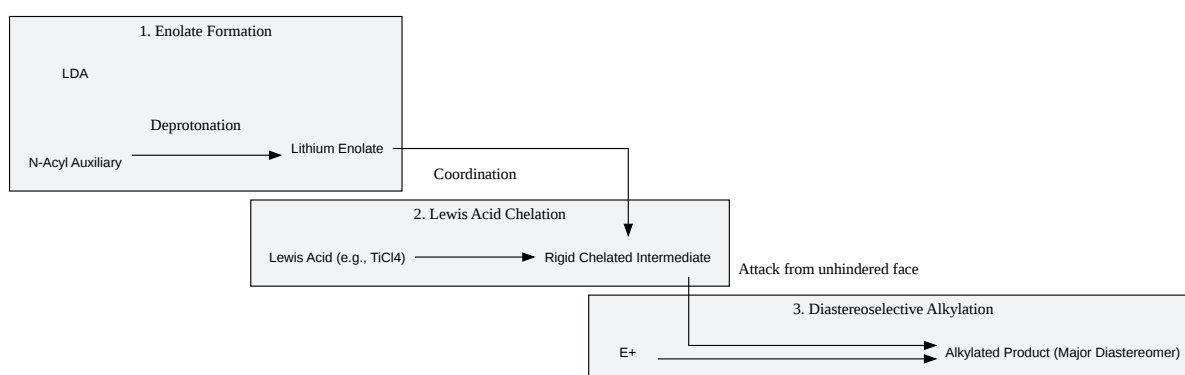

[Click to download full resolution via product page](#)

Caption: Mechanism of Lewis Acid-Mediated Diastereoselective Alkylation.

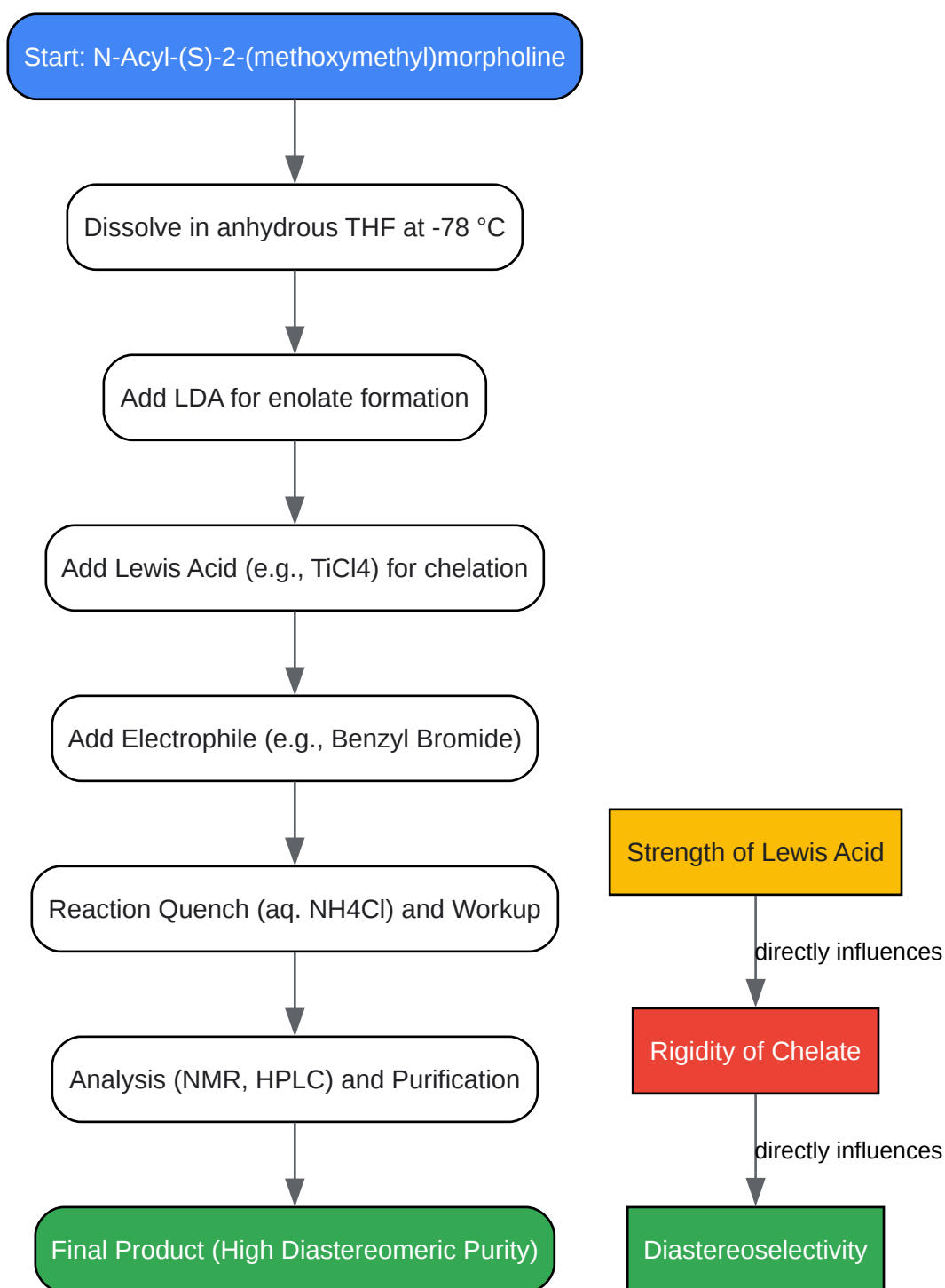

[Click to download full resolution via product page](#)

- To cite this document: BenchChem. [Technical Support Center: Diastereoselectivity with (S)-2-(Methoxymethyl)morpholine]. BenchChem, [2026]. [Online PDF]. Available at: [<https://www.benchchem.com/product/b599894#effect-of-lewis-acid-on-diastereoselectivity-with-s-2-methoxymethyl-morpholine>]

Disclaimer & Data Validity:

The information provided in this document is for Research Use Only (RUO) and is strictly not intended for diagnostic or therapeutic procedures. While BenchChem strives to provide accurate protocols, we make no warranties, express or implied, regarding the fitness of this product for every specific experimental setup.

Technical Support: The protocols provided are for reference purposes. Unsure if this reagent suits your experiment? [[Contact our Ph.D. Support Team for a compatibility check](#)]

Need Industrial/Bulk Grade? [Request Custom Synthesis Quote](#)

BenchChem

Our mission is to be the trusted global source of essential and advanced chemicals, empowering scientists and researchers to drive progress in science and industry.

Contact

Address: 3281 E Guasti Rd
Ontario, CA 91761, United States
Phone: (601) 213-4426
Email: info@benchchem.com