

# Spectroscopic Profile of 5-(2-Chlorophenyl)pentanoic Acid: A Technical Guide

**Author:** BenchChem Technical Support Team. **Date:** April 2026

## Compound of Interest

Compound Name: 5-(2-Chlorophenyl)pentanoic acid

CAS No.: 100126-82-7

Cat. No.: B599978

[Get Quote](#)

This technical guide provides a comprehensive analysis of the expected spectroscopic data for **5-(2-chlorophenyl)pentanoic acid**, a compound of interest in synthetic chemistry and drug development. In the absence of a complete, publicly available experimental dataset for this specific molecule, this document leverages established principles of nuclear magnetic resonance (NMR) spectroscopy, infrared (IR) spectroscopy, and mass spectrometry (MS) to present a detailed, predicted spectroscopic profile. This guide is intended for researchers, scientists, and professionals in drug development who require a thorough understanding of the structural characterization of this and related molecules.

## Introduction

**5-(2-Chlorophenyl)pentanoic acid** is a carboxylic acid derivative containing a chlorophenyl substituent. Its molecular structure presents a unique combination of an aromatic system, an aliphatic chain, and a carboxylic acid moiety, each contributing distinct features to its spectroscopic signature. Understanding these features is paramount for its unambiguous identification, purity assessment, and for tracking its transformations in chemical reactions. This guide will delve into the predicted  $^1\text{H}$  NMR,  $^{13}\text{C}$  NMR, IR, and mass spectra, providing a rationale for the expected chemical shifts, vibrational frequencies, and fragmentation patterns.

# Molecular Structure and Atom Numbering

To facilitate the discussion of the spectroscopic data, the following atom numbering scheme will be used for **5-(2-chlorophenyl)pentanoic acid**.

Caption: Molecular structure and atom numbering for **5-(2-Chlorophenyl)pentanoic acid**.

## I. <sup>1</sup>H Nuclear Magnetic Resonance (NMR) Spectroscopy

The <sup>1</sup>H NMR spectrum of **5-(2-chlorophenyl)pentanoic acid** is predicted to exhibit distinct signals corresponding to the aromatic protons, the aliphatic chain protons, and the carboxylic acid proton. The chemical shifts are influenced by the electron-withdrawing effects of the chlorine atom and the carboxylic acid group.

Expected <sup>1</sup>H NMR Data:

Proton(s)	Predicted Chemical Shift ( $\delta$ , ppm)	Predicted Multiplicity	Predicted Integration
H (Carboxylic Acid)	10.0 - 12.0	Singlet (broad)	1H
H-6' (Aromatic)	7.35 - 7.45	Multiplet	1H
H-3', H-4', H-5' (Aromatic)	7.10 - 7.30	Multiplet	3H
H-5 (Aliphatic)	2.70 - 2.85	Triplet	2H
H-2 (Aliphatic)	2.30 - 2.45	Triplet	2H
H-3, H-4 (Aliphatic)	1.60 - 1.80	Multiplet	4H

Interpretation:

- **Carboxylic Acid Proton:** The proton of the carboxylic acid group is expected to appear as a broad singlet in the downfield region of the spectrum (10-12 ppm). Its broadness is a result of hydrogen bonding and chemical exchange.

- **Aromatic Protons:** The four protons on the chlorophenyl ring will appear in the aromatic region (7.10-7.45 ppm). Due to the ortho substitution of the chlorine atom, these protons are chemically non-equivalent and will likely exhibit complex splitting patterns (multiplets). The proton adjacent to the chlorine atom (H-6') is expected to be the most deshielded.
- **Aliphatic Protons:** The protons on the pentanoic acid chain will appear in the upfield region of the spectrum. The methylene group attached to the aromatic ring (H-5) will be deshielded compared to the other methylene groups and is predicted to be a triplet. Similarly, the methylene group alpha to the carbonyl group (H-2) will also be a triplet. The remaining two methylene groups (H-3 and H-4) will likely appear as a complex multiplet in the 1.60-1.80 ppm range.

## II. <sup>13</sup>C Nuclear Magnetic Resonance (NMR) Spectroscopy

The <sup>13</sup>C NMR spectrum will provide information about the carbon framework of the molecule. The chemical shifts are influenced by the hybridization of the carbon atoms and the electronic effects of the substituents.

Expected <sup>13</sup>C NMR Data:

Carbon(s)	Predicted Chemical Shift (δ, ppm)
C-1 (Carbonyl)	175.0 - 180.0
C-1' (Aromatic, C-substituted)	140.0 - 145.0
C-2' (Aromatic, C-Cl)	132.0 - 135.0
C-3', C-4', C-5', C-6' (Aromatic)	125.0 - 130.0
C-5 (Aliphatic)	34.0 - 38.0
C-2 (Aliphatic)	33.0 - 37.0
C-3, C-4 (Aliphatic)	24.0 - 30.0

Interpretation:

- **Carbonyl Carbon:** The carbon of the carboxylic acid group (C-1) will be the most deshielded carbon and is expected to appear in the 175-180 ppm region.
- **Aromatic Carbons:** The six carbons of the chlorophenyl ring will appear in the 125-145 ppm range. The carbon atom bearing the chlorine (C-2') and the carbon atom attached to the alkyl chain (C-1') will be quaternary and may show weaker signals. Their exact chemical shifts are influenced by the substitution pattern.
- **Aliphatic Carbons:** The methylene carbons of the pentanoic acid chain will appear in the upfield region (24-38 ppm). The carbons closer to the electron-withdrawing groups (C-2 and C-5) will be more deshielded.

### III. Infrared (IR) Spectroscopy

The IR spectrum provides information about the functional groups present in the molecule. The key vibrational modes for **5-(2-chlorophenyl)pentanoic acid** are associated with the carboxylic acid and the aromatic ring.

Expected IR Absorption Bands:

Functional Group	Absorption Range (cm <sup>-1</sup> )	Intensity
O-H stretch (Carboxylic acid)	2500 - 3300	Broad, Strong
C-H stretch (Aromatic)	3000 - 3100	Medium
C-H stretch (Aliphatic)	2850 - 2960	Medium
C=O stretch (Carboxylic acid)	1700 - 1725	Strong
C=C stretch (Aromatic)	1450 - 1600	Medium
C-O stretch (Carboxylic acid)	1210 - 1320	Medium
C-Cl stretch	600 - 800	Medium

Interpretation:

- **O-H Stretch:** A very broad and strong absorption band in the 2500-3300 cm<sup>-1</sup> region is characteristic of the O-H stretching vibration of a hydrogen-bonded carboxylic acid.

- C=O Stretch: A strong, sharp absorption band around 1700-1725  $\text{cm}^{-1}$  is indicative of the carbonyl (C=O) stretching vibration of the carboxylic acid.
- C-H Stretches: Aromatic C-H stretching vibrations are expected just above 3000  $\text{cm}^{-1}$ , while aliphatic C-H stretches will appear just below 3000  $\text{cm}^{-1}$ .
- Aromatic C=C Stretches: Medium intensity bands in the 1450-1600  $\text{cm}^{-1}$  region are due to the carbon-carbon stretching vibrations within the benzene ring.
- C-Cl Stretch: The presence of the chlorine atom is expected to give rise to a medium intensity band in the fingerprint region, typically between 600 and 800  $\text{cm}^{-1}$ .

## IV. Mass Spectrometry (MS)

Mass spectrometry provides information about the molecular weight and fragmentation pattern of the molecule, which aids in structural elucidation. For **5-(2-chlorophenyl)pentanoic acid**, electron ionization (EI) would likely lead to a series of characteristic fragments.

Expected Mass Spectrometry Data (EI):

m/z	Possible Fragment
212/214	$[\text{M}]^+$ (Molecular ion)
195/197	$[\text{M} - \text{OH}]^+$
167/169	$[\text{M} - \text{COOH}]^+$
111/113	$[\text{C}_6\text{H}_4\text{Cl}]^+$
91	$[\text{C}_7\text{H}_7]^+$ (Tropylium ion)

Interpretation and Fragmentation Pathway:

The molecular ion peak  $[\text{M}]^+$  is expected at m/z 212, with a characteristic  $[\text{M}+2]^+$  peak at m/z 214 with approximately one-third the intensity, which is indicative of the presence of a single chlorine atom.

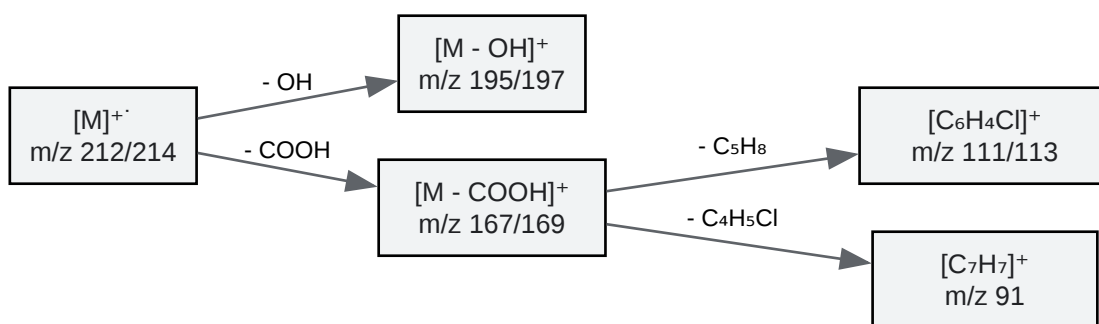

[Click to download full resolution via product page](#)

Caption: Predicted major fragmentation pathway for **5-(2-Chlorophenyl)pentanoic acid** in EI-MS.

Common fragmentation pathways for carboxylic acids include the loss of a hydroxyl radical (-OH) and the loss of the entire carboxyl group (-COOH). Alpha-cleavage and McLafferty rearrangement are also possible fragmentation pathways for the aliphatic chain. The chlorophenyl cation ( $[C_6H_4Cl]^+$ ) is a likely and stable fragment. The appearance of a tropylium ion at  $m/z$  91 is also a common feature in the mass spectra of compounds containing a benzyl group.

## Experimental Protocols

While experimental data for the title compound is not readily available, the following are general protocols for acquiring the spectroscopic data discussed.

NMR Spectroscopy ( $^1H$  and  $^{13}C$ ):

- Sample Preparation: Dissolve 5-10 mg of **5-(2-chlorophenyl)pentanoic acid** in approximately 0.6 mL of a deuterated solvent (e.g.,  $CDCl_3$ ,  $DMSO-d_6$ ) in a 5 mm NMR tube.
- Instrument: A 400 MHz or higher field NMR spectrometer.
- $^1H$  NMR Acquisition: Acquire a standard one-dimensional proton spectrum. Typical parameters include a  $90^\circ$  pulse, a relaxation delay of 1-2 seconds, and 16-32 scans.
- $^{13}C$  NMR Acquisition: Acquire a proton-decoupled  $^{13}C$  spectrum. Due to the lower natural abundance and sensitivity of the  $^{13}C$  nucleus, a larger number of scans (e.g., 1024 or more)

and a longer relaxation delay may be necessary.

#### Infrared (IR) Spectroscopy:

- **Sample Preparation:** For a solid sample, prepare a KBr pellet by grinding a small amount of the compound with dry KBr powder and pressing it into a thin, transparent disk. Alternatively, an Attenuated Total Reflectance (ATR) accessory can be used with the neat solid.
- **Instrument:** A Fourier Transform Infrared (FTIR) spectrometer.
- **Acquisition:** Record the spectrum typically from 4000 to 400  $\text{cm}^{-1}$ . A background spectrum of the empty sample compartment or the KBr pellet should be recorded and subtracted from the sample spectrum.

#### Mass Spectrometry (MS):

- **Sample Introduction:** For a volatile compound, direct insertion or gas chromatography (GC) can be used as the inlet system.
- **Ionization:** Electron Ionization (EI) at 70 eV is a standard method for generating fragments and creating a library-searchable spectrum.
- **Mass Analyzer:** A quadrupole or time-of-flight (TOF) mass analyzer can be used to separate the ions based on their mass-to-charge ratio.
- **Detection:** An electron multiplier is used to detect the ions.

## Conclusion

This technical guide provides a detailed, predicted spectroscopic profile of **5-(2-chlorophenyl)pentanoic acid** based on fundamental principles and data from analogous structures. The expected  $^1\text{H}$  NMR,  $^{13}\text{C}$  NMR, IR, and mass spectra are presented with interpretations of the key features. This information serves as a valuable resource for the identification and characterization of this compound in a research and development setting. It is important to note that while these predictions are based on sound scientific principles, experimental verification is the ultimate standard for structural confirmation.

## References

- Silverstein, R. M., Webster, F. X., Kiemle, D. J., & Bryce, D. L. (2014). Spectrometric Identification of Organic Compounds. John Wiley & Sons.
- Pavia, D. L., Lampman, G. M., Kriz, G. S., & Vyvyan, J. R. (2014). Introduction to Spectroscopy. Cengage Learning.
- NIST Chemistry WebBook. (n.d.). National Institute of Standards and Technology. Retrieved from [[Link](#)]
- Spectral Database for Organic Compounds (SDBS). (n.d.). National Institute of Advanced Industrial Science and Technology (AIST), Japan. Retrieved from [[Link](#)]
- To cite this document: BenchChem. [Spectroscopic Profile of 5-(2-Chlorophenyl)pentanoic Acid: A Technical Guide]. BenchChem, [2026]. [Online PDF]. Available at: [<https://www.benchchem.com/product/b599978/docs#spectroscopic-profile-of-5-2-chlorophenyl-pentanoic-acid-a-technical-guide>]

---

### Disclaimer & Data Validity:

The information provided in this document is for Research Use Only (RUO) and is strictly not intended for diagnostic or therapeutic procedures. While BenchChem strives to provide accurate protocols, we make no warranties, express or implied, regarding the fitness of this product for every specific experimental setup.

**Technical Support:** The protocols provided are for reference purposes. Unsure if this reagent suits your experiment?

**Need Industrial/Bulk Grade?** [Request Custom Synthesis Quote](#)

## BenchChem

Our mission is to be the trusted global source of essential and advanced chemicals, empowering scientists and researchers to drive progress in science and industry.

### Contact

Address: 3281 E Guasti Rd  
Ontario, CA 91761, United States  
Phone: (601) 213-4426  
Email: [info@benchchem.com](mailto:info@benchchem.com)

Contact our Ph.D. Support Team for a compatibility check