

Performance of Furan-Based Carboxylic Acids in Polymerization Reactions: A Comparative Guide

Author: BenchChem Technical Support Team. **Date:** May 2026

Compound of Interest

Compound Name: 2-Formylfuran-3-carboxylic acid

CAS No.: 14757-79-0

Cat. No.: B598042

[Get Quote](#)

The imperative to transition from a fossil fuel-dependent economy to one based on renewable resources has catalyzed significant research into bio-based monomers. Among these, furan derivatives, obtainable from the dehydration of sugars, have emerged as promising platform molecules for the synthesis of high-performance polymers.[1] This guide provides an in-depth comparison of the polymerization performance of **2-formylfuran-3-carboxylic acid** and a prominent alternative, 2,5-furandicarboxylic acid (FDCA), for researchers, scientists, and drug development professionals. While FDCA is a well-explored, promising bio-based substitute for petroleum-derived terephthalic acid[2][3], **2-formylfuran-3-carboxylic acid** represents a less-explored yet potentially valuable monomer. This guide will delve into their respective reactivities, polymerization pathways, and the properties of the resulting polymers, supported by experimental insights.

Introduction to Furan-Based Monomers

Furan derivatives are heterocyclic organic compounds primarily derived from agricultural and forestry waste.[1] Their rigid ring structure and potential for difunctionality make them excellent candidates for creating polymers with robust thermal and mechanical properties.[4] The most studied of these is 2,5-furandicarboxylic acid (FDCA), which is considered a top value-added

chemical from biomass.[2][5] Its structural similarity to terephthalic acid allows it to be a drop-in replacement in the production of polyesters like polyethylene terephthalate (PET), leading to the bio-based alternative polyethylene furanoate (PEF).[3][4][6] PEF exhibits superior gas barrier properties compared to PET, making it highly suitable for packaging applications.[4][6]

In contrast, **2-formylfuran-3-carboxylic acid** is a less common monomer. Its unique substitution pattern, with a carboxylic acid group at the 3-position and a formyl group at the 2-position, presents different synthetic possibilities and challenges.[7] The presence of the reactive aldehyde (formyl) group alongside the carboxylic acid opens avenues for various polymerization reactions beyond simple polyesterification.

Comparative Analysis of Polymerization Performance

The choice of monomer is critical as it dictates the polymerization method, reaction kinetics, and the final properties of the polymer. This section compares the known performance of FDCA with the projected potential of **2-formylfuran-3-carboxylic acid**.

Reactivity and Polymerization Pathways

2,5-Furandicarboxylic Acid (FDCA):

FDCA is primarily used in step-growth polymerization, specifically polycondensation, to produce polyesters and polyamides.[1] The two carboxylic acid groups readily react with diols (like ethylene glycol) or diamines. To circumvent issues like the low solubility and high melting point of FDCA, its dimethyl ester, dimethyl 2,5-furandicarboxylate (DMFDCA), is often preferred for laboratory and industrial synthesis, particularly through transesterification reactions.[8][9]

Common polymerization techniques for FDCA include:

- **Melt Polymerization:** This is a widely used industrial method involving high temperatures and vacuum to drive the reaction forward by removing the condensation byproduct (e.g., water or methanol).[6][8]
- **Solution Polymerization:** This method involves dissolving the monomers in a solvent, which can be advantageous for heat control but requires solvent removal and recycling.[8]

- Enzymatic Polymerization: Lipases, such as *Candida antarctica* lipase B (CALB), can catalyze the polymerization of FDCA derivatives under milder conditions, offering a more sustainable approach.[10][11][12]

The primary polymerization reaction for FDCA is polyesterification with a diol, as illustrated below:

Figure 1. Polycondensation of FDCA with a diol.

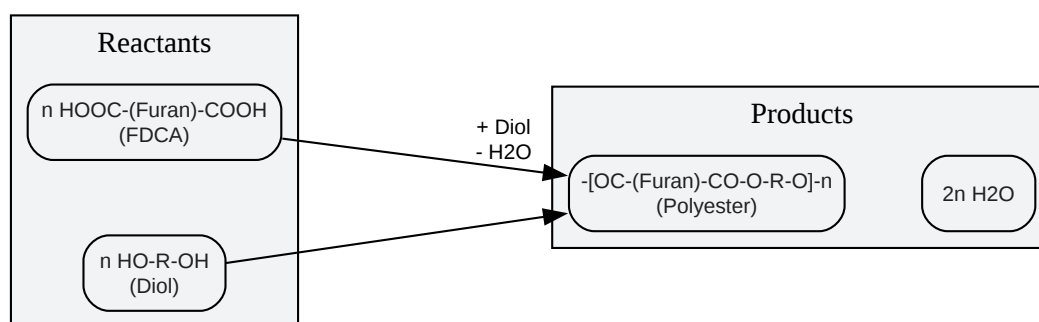

[Click to download full resolution via product page](#)

Figure 1. Polycondensation of FDCA with a diol.

2-Formylfuran-3-carboxylic acid:

Direct polymerization of **2-formylfuran-3-carboxylic acid** is more complex due to the differing reactivity of the formyl and carboxylic acid groups. Several hypothetical pathways can be envisioned:

- Reductive Polyesterification: The formyl group could be reduced to a hydroxymethyl group, creating a hydroxy acid monomer (2-(hydroxymethyl)furan-3-carboxylic acid). This monomer could then undergo self-condensation to form a polyester. This approach introduces an additional synthetic step but yields a monomer capable of direct polyesterification.
- Oxidative Polyesterification: Alternatively, the formyl group could be oxidized to a second carboxylic acid group, yielding furan-2,3-dicarboxylic acid. This resulting diacid could then be polymerized with a diol, similar to FDCA.

- Poly(Schiff base) formation: The formyl group can react with a diamine to form a poly(Schiff base), with the carboxylic acid group potentially available for subsequent cross-linking or modification.
- Direct polymerization involving both groups: It is conceivable that under specific catalytic conditions, both the formyl and carboxylic acid groups could participate in a one-pot polymerization with a suitable co-monomer containing, for example, amine and hydroxyl functionalities.

The reactivity of the furan ring itself, particularly its susceptibility to electrophilic attack, could lead to side reactions under harsh acidic conditions, a consideration in any polymerization strategy.[13]

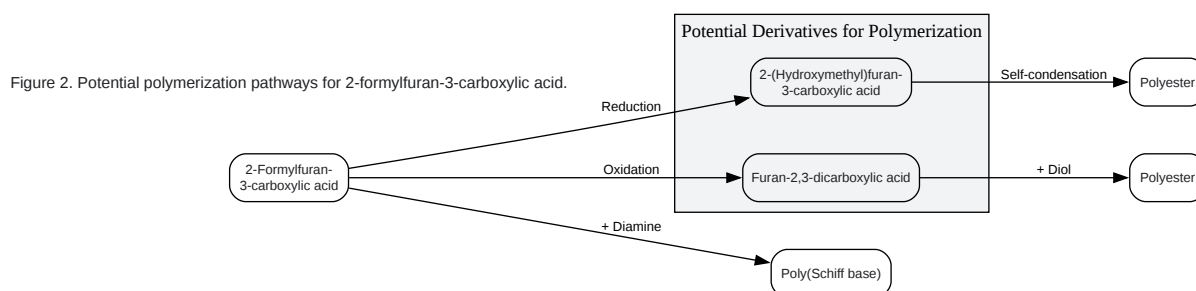

[Click to download full resolution via product page](#)

Figure 2. Potential polymerization pathways for **2-formylfuran-3-carboxylic acid**.

Comparative Data on Polymer Properties

The properties of polymers derived from these monomers are expected to differ significantly due to their structural disparities. The linear, symmetrical structure of FDCA generally leads to semi-crystalline polymers with good mechanical strength and thermal stability.[8] In contrast, the less symmetrical structure of polymers derived from **2-formylfuran-3-carboxylic acid**

would likely result in more amorphous materials with lower melting points and potentially greater solubility.

Property	Polymer from 2,5-FDCA (e.g., PEF)	Hypothetical Polymer from 2-Formylfuran-3-carboxylic acid
Monomer Symmetry	High (para-like substitution)	Low (ortho-like substitution)
Expected Crystallinity	Semi-crystalline	Likely amorphous
Glass Transition Temp. (T _g)	~85-95 °C	Expected to be lower than PEF
Melting Temp. (T _m)	~210-220 °C	Likely lower or absent
Mechanical Properties	High tensile strength, good modulus	Potentially more flexible, lower modulus
Gas Barrier Properties	Excellent (superior to PET)[4] [6]	Unknown, likely different from PEF

Experimental Protocols

To ensure scientific integrity, the following protocols are provided. The protocol for FDCA-based polyester is based on established literature, while the protocol for **2-formylfuran-3-carboxylic acid** is a proposed, self-validating system based on chemical principles.

Protocol 1: Synthesis of Poly(ethylene furanoate) (PEF) via Melt Polymerization

This protocol describes a two-stage melt polymerization process using dimethyl 2,5-furandicarboxylate (DMFDCA) and ethylene glycol.

Materials:

- Dimethyl 2,5-furandicarboxylate (DMFDCA)
- Ethylene Glycol (EG)

- Antimony(III) oxide (Sb_2O_3) or other suitable catalyst
- Three-necked round-bottom flask
- Mechanical stirrer
- Nitrogen inlet
- Condenser and collection flask
- High-vacuum pump

Procedure:

- Ester Interchange (Oligomerization):
 - Charge the flask with DMFDCA, ethylene glycol (in molar excess, e.g., 1:2.2 ratio), and the catalyst (e.g., 0.05 mol% Sb_2O_3).
 - Equip the flask for distillation.
 - Under a slow nitrogen stream, heat the mixture with stirring to 160-190 °C.
 - Methanol will be produced as a byproduct and should be collected. The reaction is monitored by the amount of methanol collected.
 - Continue this stage for 2-4 hours until approximately 90% of the theoretical amount of methanol has been distilled off.
- Polycondensation:
 - Gradually increase the temperature to 220-250 °C.
 - Simultaneously, gradually reduce the pressure to below 1 mbar using a high-vacuum pump.
 - Excess ethylene glycol will distill off.

- The viscosity of the mixture will increase significantly. The reaction is monitored by the torque on the mechanical stirrer.
- Continue the reaction for 3-5 hours until the desired viscosity is achieved.
- Cool the reactor under nitrogen and extrude the resulting polymer.

Characterization:

- The molecular weight (M_n , M_w) and polydispersity index (PDI) of the resulting PEF can be determined using Gel Permeation Chromatography (GPC).
- Thermal properties (T_g , T_m) can be analyzed using Differential Scanning Calorimetry (DSC).

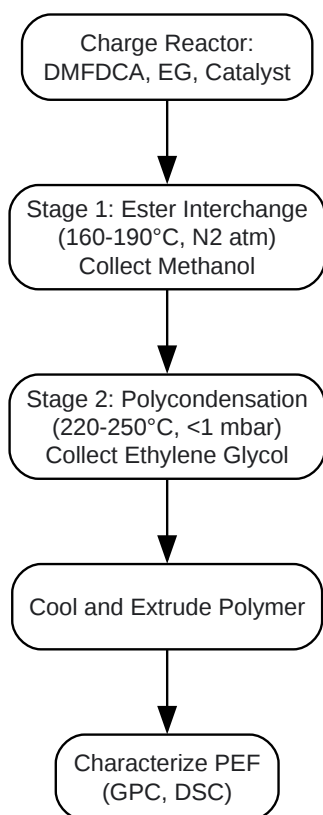

Figure 3. Workflow for PEF synthesis via melt polymerization.

[Click to download full resolution via product page](#)

Figure 3. Workflow for PEF synthesis via melt polymerization.

Protocol 2: Proposed Synthesis of a Polyester from 2-Formylfuran-3-carboxylic acid via Reductive Self-Condensation

This hypothetical protocol involves an initial reduction of the formyl group followed by polymerization.

Materials:

- **2-Formylfuran-3-carboxylic acid**
- Sodium borohydride (NaBH_4) or other selective reducing agent
- Suitable solvent (e.g., THF, Dioxane)
- Acid catalyst for esterification (e.g., p-toluenesulfonic acid)
- Dean-Stark apparatus for water removal
- Standard glassware for organic synthesis

Procedure:

- In-situ Reduction to Hydroxy Acid:
 - Dissolve **2-formylfuran-3-carboxylic acid** in the chosen solvent in a round-bottom flask under a nitrogen atmosphere.
 - Cool the solution in an ice bath.
 - Slowly add a stoichiometric amount of NaBH_4 to selectively reduce the formyl group to a hydroxymethyl group. The carboxylic acid group should remain largely unreacted under these conditions.
 - Monitor the reaction by TLC or LC-MS until the starting material is consumed.
 - Carefully quench the reaction with a dilute acid (e.g., 1M HCl) to neutralize excess NaBH_4 and protonate the carboxylate.

- Extract the resulting 2-(hydroxymethyl)furan-3-carboxylic acid into an organic solvent and dry.
- Polycondensation:
 - Transfer the crude hydroxy acid to a flask equipped with a Dean-Stark trap and condenser.
 - Add the acid catalyst (e.g., 0.5 mol%).
 - Heat the mixture to reflux. Water produced during the self-condensation will be collected in the Dean-Stark trap.
 - Continue the reaction until no more water is collected.
 - Isolate the polymer by precipitation in a non-solvent (e.g., cold methanol or water).
 - Dry the polymer under vacuum.

Self-Validating System:

- The success of the reduction step must be confirmed (e.g., by ^1H NMR to observe the disappearance of the aldehyde proton signal and appearance of methylene protons) before proceeding to polymerization.
- The progress of the polymerization can be monitored by the amount of water collected and by periodically taking samples for molecular weight analysis (GPC).

Conclusion

2,5-Furandicarboxylic acid is a well-established, high-performance bio-based monomer with a clear pathway to replacing petroleum-derived plastics in various applications.^{[4][14]} Its symmetrical structure and reactivity lead to predictable polymerization behavior and desirable polymer properties.

2-Formylfuran-3-carboxylic acid, while not extensively studied in polymerization, presents intriguing possibilities due to its unique bifunctional and asymmetric nature. Its successful application in polymer synthesis will likely require a multi-step approach, such as reduction or oxidation of the formyl group, to create more conventional monomers. The resulting polymers

are expected to be amorphous with properties distinct from those of FDCA-based polymers, potentially opening doors to new applications where crystallinity is not required, such as in coatings, adhesives, or as modifiers for other polymers. Further research is essential to validate these proposed pathways and fully characterize the resulting materials.

References

- Patsnap Eureka. (2025, July 3). Furan Derivatives: Plant-Based Monomers for Sustainable Polymers.
- Benchchem. Application Notes and Protocols for the Enzymatic Synthesis of Furan-Based Polymers and Co-polymers.
- Benchchem. Application Notes and Protocols for the Incorporation of 2-(2-Pentenyl)furan into Polymer Synthesis.
- Benchchem. A Comparative Review of Polymerization Techniques for 2,5-Furandicarboxylic Acid (FDCA).
- ResearchGate.
- ResearchGate. Enzymatic Polymerization of Furan-2,5-Dicarboxylic Acid-Based Furanic-Aliphatic Polyamides as Sustainable Alternatives to Polyphthalamides | Request PDF.
- Recent Progress on Bio-Based Polyesters Derived
- Bio-Based Furan-Polyesters/Graphene Nanocomposites Prepared by In Situ Polymeriz
- Furan-based thermosetting polymers for high-performance applic
- Benchchem.
- 2,5-Furandicarboxylic Acid: An Intriguing Precursor for Monomer and Polymer Synthesis.
- ACS Omega. (2023, March 2). Biobased 2,5-Bis(hydroxymethyl)
- NIH. (2023, March 2). Biobased 2,5-Bis(hydroxymethyl)
- Green Chemistry (RSC Publishing). (2024, December 20). Exploring the versatility of novel furan-based α,ω -diene carbonate monomers: synthesis, (co-)
- RSC Publishing. Enzymatic polymerization of furan-based polymers in biobased solvents.
- ResearchGate.
- ResearchGate. Furan Polymers: State of the Art and Perspectives | Request PDF.
- Encyclopedia.pub. (2022, July 18). Synthesis of 2,5-Furandicarboxylic Acid.
- ResearchGate.
- Benchchem. **2-Formylfuran-3-carboxylic acid** | 14757-79-0.

Need Custom Synthesis?

BenchChem offers custom synthesis for rare earth carbides and specific isotopic labeling.

Email: info@benchchem.com or [Request Quote Online](#).

Sources

- [1. pdf.benchchem.com \[pdf.benchchem.com\]](https://pdf.benchchem.com)
- [2. mdpi.com \[mdpi.com\]](https://mdpi.com)
- [3. Synthesis of 2,5-Furandicarboxylic Acid | Encyclopedia MDPI \[encyclopedia.pub\]](#)
- [4. Furan Derivatives: Plant-Based Monomers for Sustainable Polymers \[eureka.patsnap.com\]](#)
- [5. mdpi.com \[mdpi.com\]](https://mdpi.com)
- [6. pdf.benchchem.com \[pdf.benchchem.com\]](https://pdf.benchchem.com)
- [7. benchchem.com \[benchchem.com\]](https://benchchem.com)
- [8. Recent Progress on Bio-Based Polyesters Derived from 2,5-Furandicarboxylic Acid \(FDCA\) - PMC \[pmc.ncbi.nlm.nih.gov\]](#)
- [9. researchgate.net \[researchgate.net\]](https://researchgate.net)
- [10. pdf.benchchem.com \[pdf.benchchem.com\]](https://pdf.benchchem.com)
- [11. researchgate.net \[researchgate.net\]](https://researchgate.net)
- [12. Enzymatic polymerization of furan-based polymers in biobased solvents - RSC Sustainability \(RSC Publishing\) \[pubs.rsc.org\]](#)
- [13. pdf.benchchem.com \[pdf.benchchem.com\]](https://pdf.benchchem.com)
- [14. researchgate.net \[researchgate.net\]](https://researchgate.net)
- To cite this document: BenchChem. [Performance of Furan-Based Carboxylic Acids in Polymerization Reactions: A Comparative Guide]. BenchChem, [2026]. [Online PDF]. Available at: [<https://www.benchchem.com/product/b598042/docs#performance-of-furan-based-carboxylic-acids-in-polymerization-reactions-a-comparative-guide>]

Disclaimer & Data Validity:

The information provided in this document is for Research Use Only (RUO) and is strictly not intended for diagnostic or therapeutic procedures. While BenchChem strives to provide accurate protocols, we make no warranties, express or implied, regarding the fitness of this product for every specific experimental setup.

Technical Support: The protocols provided are for reference purposes. Unsure if this reagent suits your experiment?

Need Industrial/Bulk Grade? [Request Custom Synthesis Quote](#)

BenchChem

Our mission is to be the trusted global source of essential and advanced chemicals, empowering scientists and researchers to drive progress in science and industry.

Contact

Address: 3281 E Guasti Rd
Ontario, CA 91761, United States
Phone: (601) 213-4426
Email: info@benchchem.com

[Contact our Ph.D. Support Team for a compatibility check](#)