

# A Comprehensive Technical Guide to Phosphine-Based Ligands in Catalysis

**Author:** BenchChem Technical Support Team. **Date:** May 2026

## Compound of Interest

**Compound Name:** 2-(Di-*p*-tolylphosphino)benzaldehyde

**CAS No.:** 1202865-03-9

**Cat. No.:** B598235

[Get Quote](#)

For Researchers, Scientists, and Drug Development Professionals

## Abstract

Phosphine-based ligands are a cornerstone of modern homogeneous catalysis, enabling a vast array of chemical transformations critical to pharmaceutical synthesis, materials science, and industrial chemistry. Their remarkable success stems from the systematic and predictable tunability of their steric and electronic properties, which profoundly influence the activity, selectivity, and stability of transition metal catalysts.[1][2] This guide provides an in-depth exploration of phosphine ligands, covering their fundamental properties, classification, and application in key catalytic reactions. It includes structured quantitative data, detailed experimental protocols for ligand synthesis and catalytic applications, and visualizations of core catalytic cycles to offer a comprehensive resource for both seasoned researchers and those new to the field.

## Introduction to Phosphine Ligands

Phosphine ligands are organophosphorus compounds with the general formula  $PR_3$ , where 'R' can be an alkyl, aryl, or other organic substituent.[3] They function as L-type, two-electron donors, forming coordinate bonds with transition metals through the lone pair of electrons on the phosphorus atom.[4] This interaction stabilizes the metal center and modulates its reactivity.[2][5] The first applications of phosphine ligands in catalysis date back to the mid-20th century, notably in Reppe chemistry for alkyne functionalization.[6] Since then, their development has been pivotal in the advancement of powerful cross-coupling reactions and other transformations.[7]

The utility of phosphine ligands is primarily due to the ability to independently modify their steric and electronic characteristics by simply changing the 'R' groups.[1][8] This allows for the rational design of ligands tailored to the specific demands of a catalytic transformation.

## Classification of Phosphine Ligands

Phosphine ligands can be classified based on several criteria, including denticity, the nature of the phosphorus-bound groups, and chirality.[9] A logical classification workflow helps in selecting the appropriate ligand for a given catalytic system.

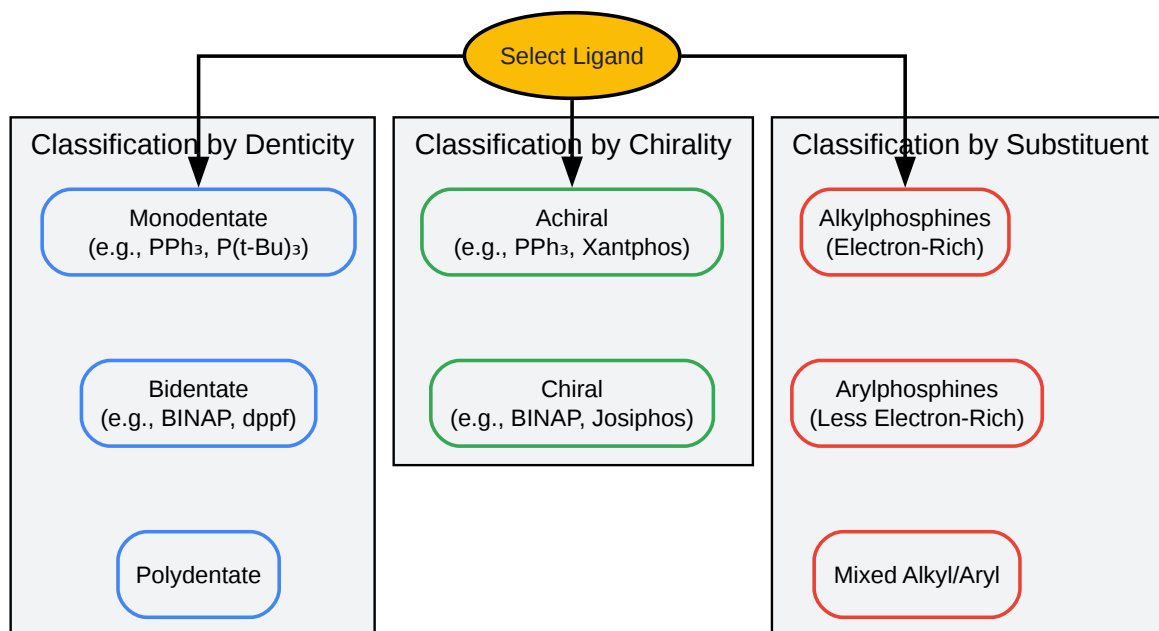

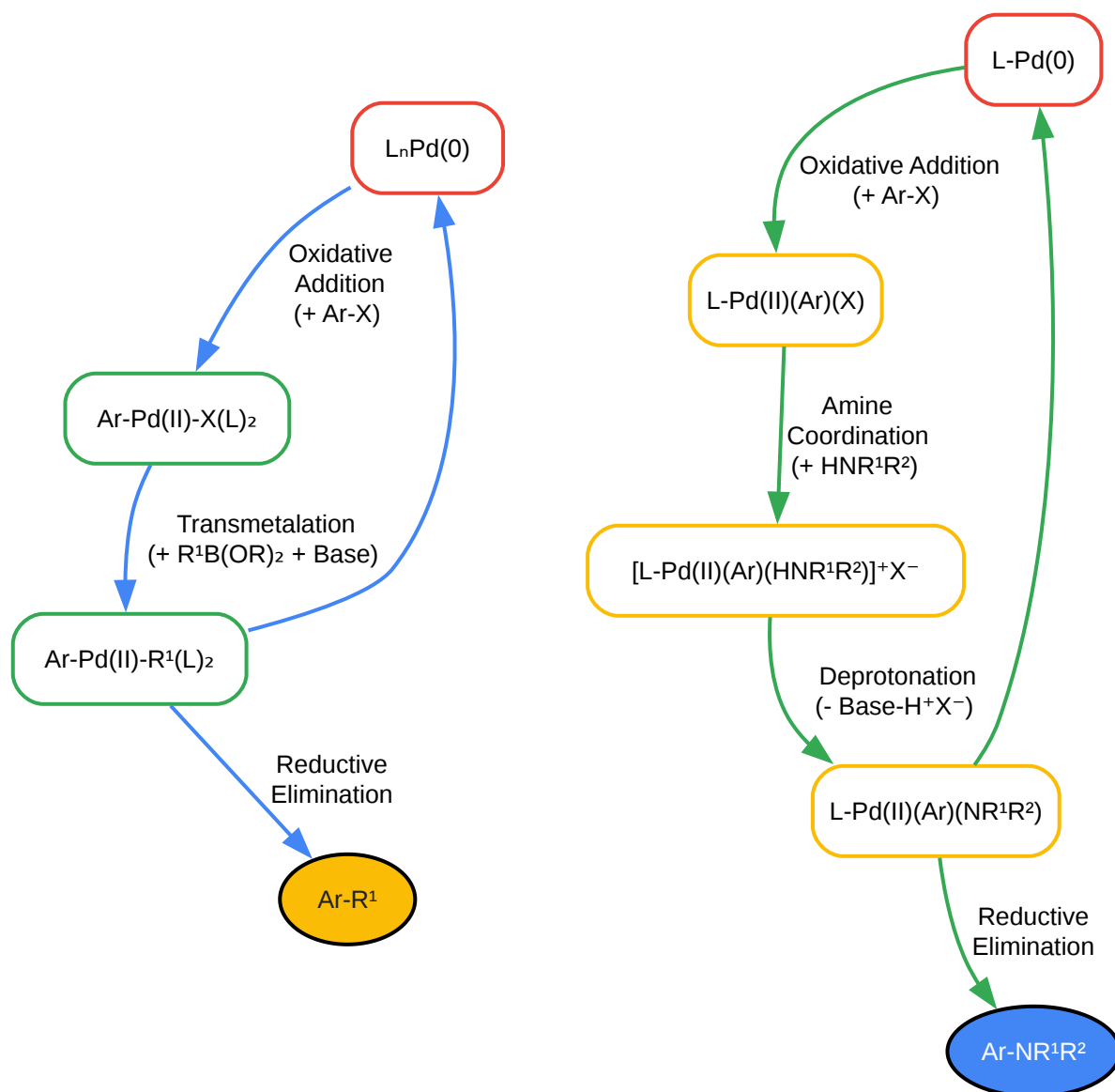

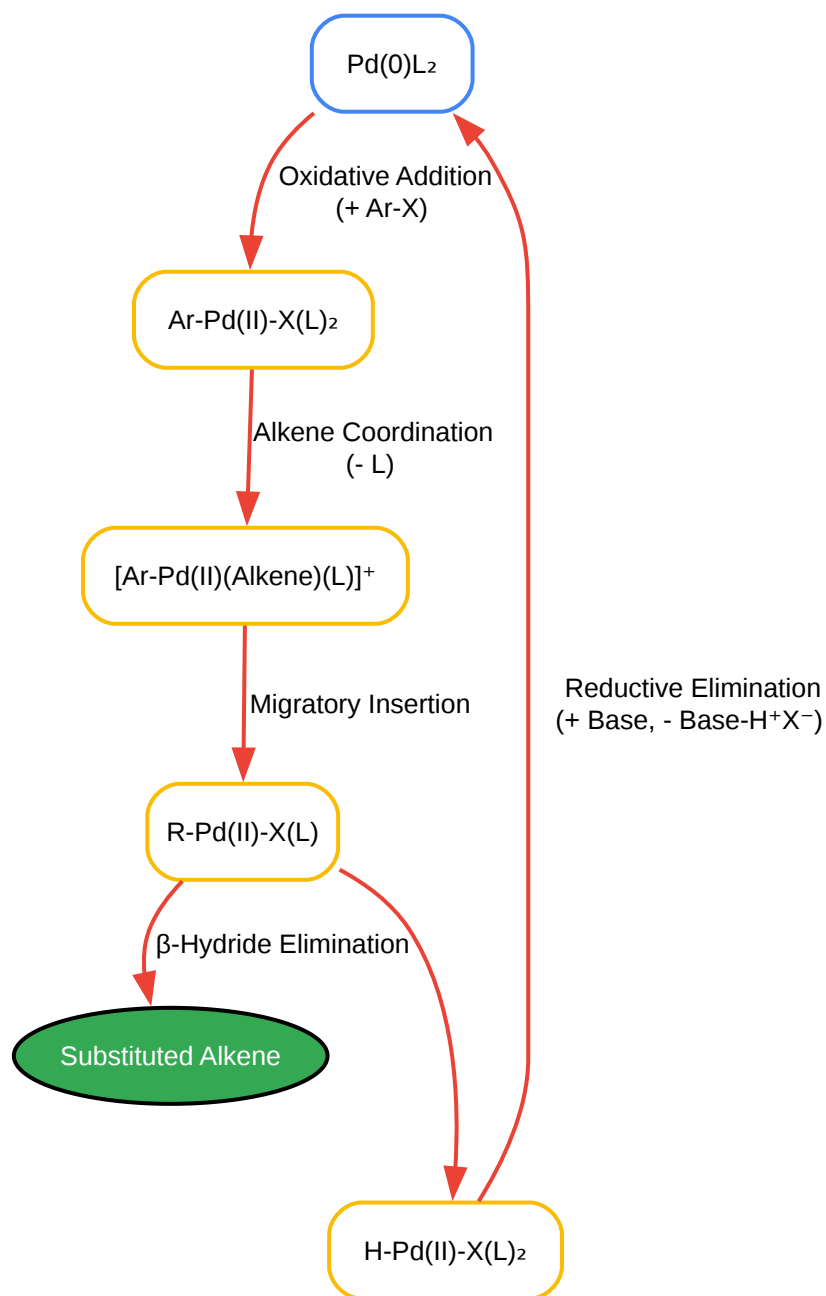

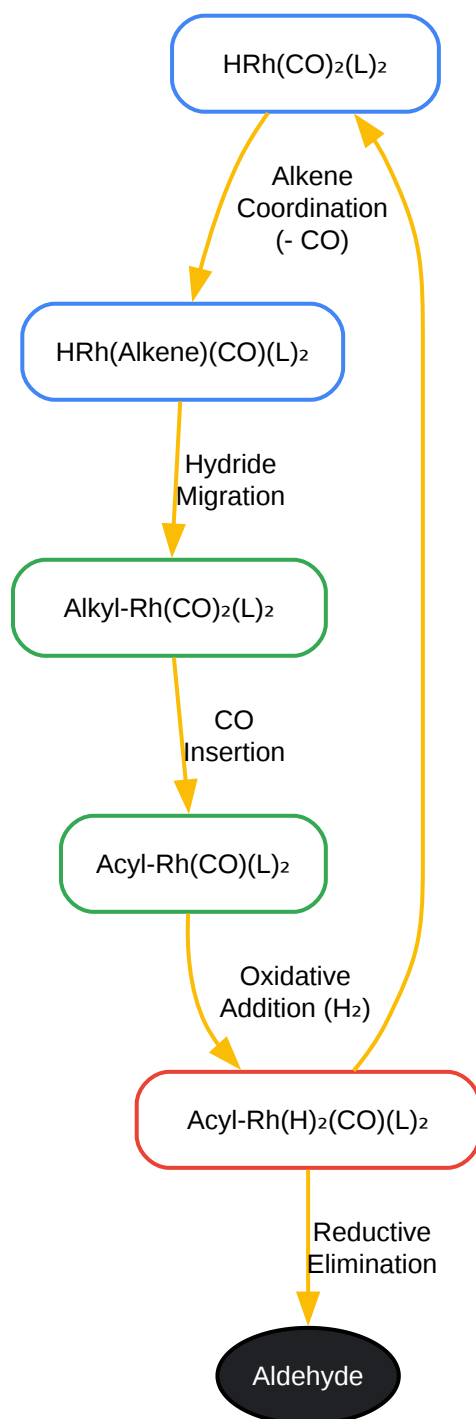

[Click to download full resolution via product page](#)

### Need Custom Synthesis?

BenchChem offers custom synthesis for rare earth carbides and specific isotopic labeling.

Email: [info@benchchem.com](mailto:info@benchchem.com) or [Request Quote Online](#).

## References

- [1. pubs.acs.org \[pubs.acs.org\]](https://pubs.acs.org)
- [2. researchgate.net \[researchgate.net\]](https://researchgate.net)
- [3. Buchwald–Hartwig amination - Wikipedia \[en.wikipedia.org\]](https://en.wikipedia.org)
- [4. chem.libretexts.org \[chem.libretexts.org\]](https://chem.libretexts.org)
- [5. SPhos - Wikipedia \[en.wikipedia.org\]](https://en.wikipedia.org)
- [6. Ligand cone angle - Wikipedia \[en.wikipedia.org\]](https://en.wikipedia.org)
- [7. nbinno.com \[nbinno.com\]](https://nbinno.com)
- [8. pubs.acs.org \[pubs.acs.org\]](https://pubs.acs.org)
- [9. benchchem.com \[benchchem.com\]](https://benchchem.com)
- To cite this document: BenchChem. [A Comprehensive Technical Guide to Phosphine-Based Ligands in Catalysis]. BenchChem, [2026]. [Online PDF]. Available at: [\[https://www.benchchem.com/product/b598235/docs#a-comprehensive-technical-guide-to-phosphine-based-ligands-in-catalysis\]](https://www.benchchem.com/product/b598235/docs#a-comprehensive-technical-guide-to-phosphine-based-ligands-in-catalysis)

---

### Disclaimer & Data Validity:

The information provided in this document is for Research Use Only (RUO) and is strictly not intended for diagnostic or therapeutic procedures. While BenchChem strives to provide accurate protocols, we make no warranties, express or implied, regarding the fitness of this product for every specific experimental setup.

**Technical Support:** The protocols provided are for reference purposes. Unsure if this reagent suits your experiment?

**Need Industrial/Bulk Grade?** [Request Custom Synthesis Quote](#)

# BenchChem

Our mission is to be the trusted global source of essential and advanced chemicals, empowering scientists and researchers to drive progress in science and industry.

## Contact

Address: 3281 E Guasti Rd

Ontario, CA 91761, United States

Phone: (601) 213-4426

Email: [info@benchchem.com](mailto:info@benchchem.com)

[Contact our Ph.D. Support Team for a compatibility check](#)