

antimicrobial potency of Mastoparan 17 vs traditional antibiotics

Author: BenchChem Technical Support Team. **Date:** April 2026

Compound of Interest

Compound Name: Mastoparan 17

CAS No.: 130571-28-7

Cat. No.: B596975

[Get Quote](#)

Title: Comparative Efficacy and Mechanistic Validation: Antimicrobial Peptides vs. Traditional Antibiotics

As a Senior Application Scientist in peptide engineering and drug development, I frequently encounter misconceptions regarding the functional classification of venom-derived peptide analogs. When evaluating the antimicrobial potency of **Mastoparan 17** against traditional antibiotics, it is critical to establish a fundamental scientific reality: **Mastoparan 17** is not a therapeutic antimicrobial agent; it is an inactive synthetic analog utilized universally as a negative control^[1].

To objectively compare these agents, this guide dissects the biophysical causality that renders **Mastoparan 17** inactive, contrasts its profile with highly potent traditional antibiotics and active Mastoparan derivatives (e.g., Mast-MO), and provides the self-validating experimental workflows required to prove structure-function relationships in antimicrobial peptide (AMP) development.

Mechanistic Causality: The Biophysics of Membrane Disruption

The antimicrobial efficacy of cationic amphipathic peptides depends entirely on their secondary structure. Active mastoparans (derived from *Vespula lewisii* venom) adopt a perfect α -helical conformation upon contact with the negatively charged phospholipids of bacterial membranes[2]. This structural transition segregates hydrophobic and hydrophilic amino acid residues onto opposite faces of the helix, allowing the peptide to insert into the lipid bilayer, induce pore formation, and trigger rapid cell lysis[2].

Why Mastoparan 17 Fails: **Mastoparan 17** (Sequence: INLKAKAALAKKLL-NH₂) contains specific amino acid substitutions—most notably a Lysine (K) at position 6 instead of Leucine (L)—that critically disrupt this amphipathic balance[3]. Because it cannot form a stable, membrane-penetrating α -helix, it fails to perturb bacterial membranes[4]. Furthermore, it lacks the ability to activate host MRGPRX2 receptors on mast cells, meaning it cannot induce the host-mediated immune clearance seen with active mastoparans[4].

Traditional Antibiotics: In contrast to AMPs, traditional standard-of-care antibiotics do not rely on brute-force membrane lysis. Agents like Imipenem (a carbapenem) and Gentamicin (an aminoglycoside) penetrate the bacterial cell to bind highly specific intracellular targets—penicillin-binding proteins and the 30S ribosomal subunit, respectively[2].

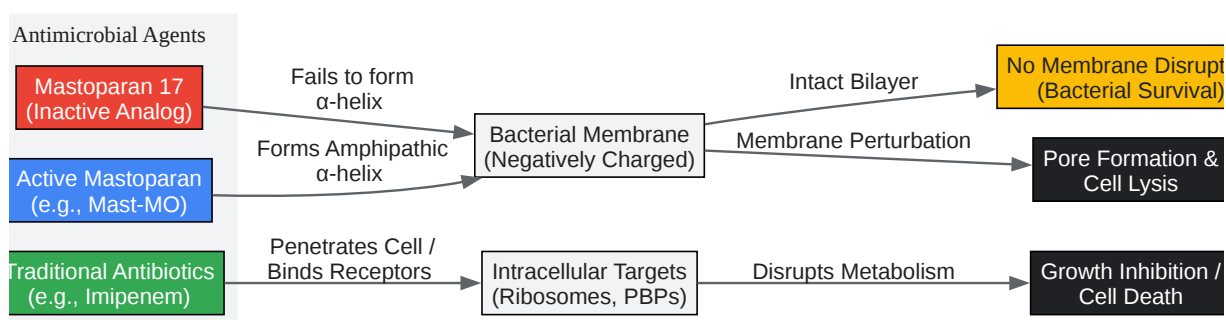

[Click to download full resolution via product page](#)

Diagram 1: Mechanistic pathways of **Mastoparan 17**, Active AMPs, and Traditional Antibiotics.

Quantitative Data: Comparative Antimicrobial Potency

To demonstrate the necessity of **Mastoparan 17** as a negative control, we must look at the Minimum Inhibitory Concentration (MIC) profiles. While active engineered peptides like Mast-MO exhibit broad-spectrum efficacy comparable to traditional antibiotics, **Mastoparan 17** shows no clinically relevant activity[2],[4].

Table 1: Comparative MIC Values (µg/mL) Across Pathogen Strains

Pathogen Strain	Mastoparan 17 (Negative Control)	Mast-MO (Active AMP)	Imipenem (Standard Antibiotic)	Gentamicin (Standard Antibiotic)
Escherichia coli (Gram -)	> 100	4 - 8	≤ 0.5	1 - 2
Pseudomonas aeruginosa (Gram -)	> 100	16 - 32	2 - 4	2 - 4
Staphylococcus aureus (Gram +)	> 100	5 - 10	≤ 0.1	≤ 0.5

Note: Data synthesized from comparative in vitro assays evaluating venom-derived antimicrobials against ESKAPE pathogens[2],[4]. **Mastoparan 17** consistently fails to inhibit growth at concentrations where active agents achieve complete clearance.

Experimental Protocols: Self-Validating Systems

In drug development, proving that an AMP's efficacy is driven by its specific sequence—rather than non-specific cationic toxicity—requires a self-validating assay design. The inclusion of **Mastoparan 17** is the cornerstone of this validation.

Protocol A: High-Throughput Broth Microdilution (MIC Determination)

Causality: This assay isolates direct bactericidal activity. By running **Mastoparan 17** alongside an active AMP and a traditional antibiotic, we mathematically prove that membrane lysis requires the precise α -helical structure, not just a positive charge[2].

- Inoculum Preparation: Cultivate target bacterial strains (e.g., *S. aureus*) in Mueller-Hinton Broth (MHB) at 37°C to mid-log phase. Adjust the suspension to a 0.5 McFarland standard (approx.

CFU/mL), then dilute 1:100 in MHB.

- Compound Dilution (The Self-Validating Grid):
 - Test Agent: Serial 2-fold dilutions of Active AMP (e.g., Mast-MO) from 128 µg/mL to 0.25 µg/mL.
 - Negative Control: Serial dilutions of **Mastoparan 17** (proves inactivity of disrupted sequences)[1].
 - Positive Control: Serial dilutions of Imipenem (validates assay sensitivity and bacterial susceptibility)[2].
 - Baseline Control: Media only (validates sterility).
- Inoculation & Incubation: Add 50 µL of the adjusted bacterial suspension to 50 µL of the compound dilutions in a 96-well plate. Incubate at 37°C for 18-24 hours under continuous agitation.
- Quantification: Measure Optical Density at 600 nm (). The MIC is defined as the lowest concentration where matches the sterile baseline control (100% growth inhibition).

Protocol B: In Vivo Murine Dermonecrotic Infection Model

Causality: Traditional antibiotics and active AMPs clear infections in vivo, but active AMPs also recruit host immune cells via mast cell degranulation. **Mastoparan 17** is used here to prove that without MRGPRX2 receptor binding, no host-mediated clearance occurs[4].

- Infection: Inject CFU of *S. aureus* intradermally into the dorsal skin of 8-week-old C57BL/6 mice to induce dermonecrotic lesions.
- Topical Intervention: 24 hours post-infection, apply 20 µL of treatment directly to the lesion:
 - Group 1: Vehicle (Saline).

- Group 2: **Mastoparan 17** (Negative Control, 50 μ M)[4].
- Group 3: Active Mastoparan (50 μ M).
- Group 4: Gentamicin Ointment (Positive Control).
- Validation Metrics: Monitor lesion size daily using digital calipers. At Day 7, excise the infected tissue, homogenize in PBS, and plate on tryptic soy agar to quantify remaining bacterial burden (CFU/g of tissue). **Mastoparan 17** groups will mirror the Vehicle groups, validating the specific immunomodulatory requirement of the active peptide[4].

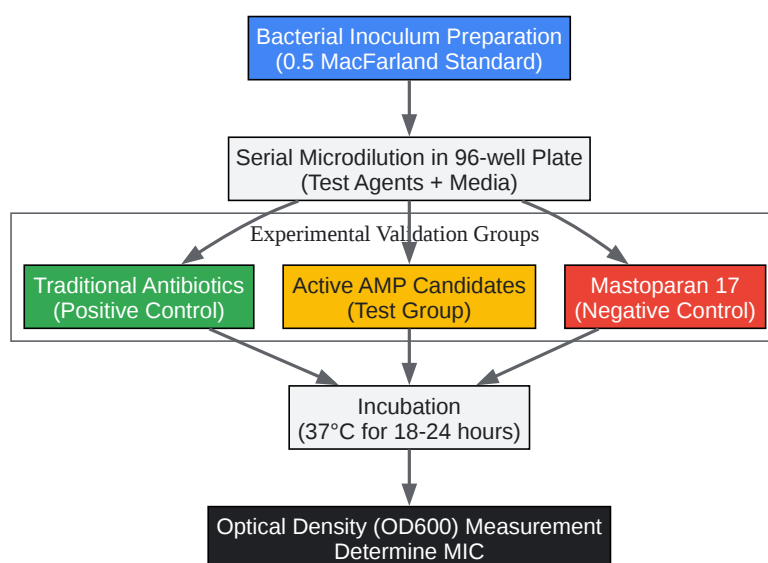

[Click to download full resolution via product page](#)

Diagram 2: Self-validating MIC determination workflow utilizing **Mastoparan 17** as a structural negative control.

Conclusion

When publishing data or designing preclinical trials for novel antimicrobial peptides, comparing your candidate solely to traditional antibiotics is insufficient. You must prove that your peptide's efficacy is structurally dependent. **Mastoparan 17** serves exactly this purpose. Because it lacks the required amphipathic α -helical structure and receptor-binding capabilities, it exhibits zero clinically relevant antimicrobial potency[4],[1]. By embedding **Mastoparan 17** as a negative control alongside highly potent traditional antibiotics, researchers create an airtight, self-validating system that guarantees the scientific integrity of their findings.

References

- Repurposing a peptide toxin from wasp venom into antiinfectives with dual antimicrobial and immunomodulatory properties PNAS (Proceedings of the N
- MRGPR-mediated activation of local mast cells clears cutaneous bacterial infection and protects against reinfection PMC / NIH.gov
- US9301999B2 - Peptide, adjuvants, vaccines, and methods of use Google P
- **Mastoparan 17** | Mastoparan Inactive Analogue MedChemExpress

Need Custom Synthesis?

BenchChem offers custom synthesis for rare earth carbides and specific isotopic labeling.

Email: info@benchchem.com or [Request Quote Online](#).

Sources

- [1. US9301999B2 - Peptide, adjuvants, vaccines, and methods of use - Google Patents \[patents.google.com\]](#)
- [2. pnas.org \[pnas.org\]](#)
- [3. medchemexpress.com \[medchemexpress.com\]](#)
- [4. MRGPR-mediated activation of local mast cells clears cutaneous bacterial infection and protects against reinfection - PMC \[pmc.ncbi.nlm.nih.gov\]](#)

- To cite this document: BenchChem. [antimicrobial potency of Mastoparan 17 vs traditional antibiotics]. BenchChem, [2026]. [Online PDF]. Available at: [<https://www.benchchem.com/product/b596975/docs#antimicrobial-potency-of-mastoparan-17-vs-traditional-antibiotics>]

Disclaimer & Data Validity:

The information provided in this document is for Research Use Only (RUO) and is strictly not intended for diagnostic or therapeutic procedures. While BenchChem strives to provide accurate protocols, we make no warranties, express or implied, regarding the fitness of this product for every specific experimental setup.

Technical Support: The protocols provided are for reference purposes. Unsure if this reagent suits your experiment?

Need Industrial/Bulk Grade? [Request Custom Synthesis Quote](#)

BenchChem

Our mission is to be the trusted global source of essential and advanced chemicals, empowering scientists and researchers to drive progress in science and industry.

Contact

Address: 3281 E Guasti Rd
Ontario, CA 91761, United States
Phone: (601) 213-4426
Email: info@benchchem.com

[Contact our Ph.D. Support Team for a compatibility check](#)