

Technical Support Center: Copper-Catalyzed 1,2,4-Triazole Synthesis

Author: BenchChem Technical Support Team. **Date:** May 2026

Compound of Interest

Compound Name: *5-Benzyl-3-chloro-1H-1,2,4-triazole*

CAS No.: *1256643-53-4*

Cat. No.: *B596783*

[Get Quote](#)

Welcome to the technical support center for copper-catalyzed 1,2,4-triazole synthesis. This guide is designed for researchers, scientists, and professionals in drug development. Here, we address common challenges encountered during the synthesis of 1,2,4-triazoles using copper catalysis, providing in-depth, field-proven insights in a troubleshooting-focused question-and-answer format. Our goal is to not only offer solutions but also to explain the underlying chemical principles to empower you in your experimental work.

Frequently Asked Questions (FAQs) & Troubleshooting

Issue 1: Low or No Product Yield

Question: My copper-catalyzed reaction is resulting in a very low yield or no desired 1,2,4-triazole product. What are the potential causes and how can I rectify this?

Answer: Low or no yield in a copper-catalyzed 1,2,4-triazole synthesis can stem from several factors, primarily related to the catalyst's activity, the integrity of your starting materials, and the

reaction conditions.

- **Catalyst Inactivity:** The active catalytic species in these reactions is typically a Cu(I) species. If you are starting with a Cu(II) salt (e.g., CuSO₄ or Cu(OAc)₂), a reducing agent is often necessary to generate the active Cu(I) catalyst in situ. Inadequate reduction will lead to a stalled reaction. Conversely, the Cu(I) species can be sensitive to oxidation by atmospheric oxygen, which would render it inactive.[1][2][3]
 - **Troubleshooting Steps:**
 - **Inert Atmosphere:** Ensure your reaction is conducted under an inert atmosphere (e.g., nitrogen or argon) to prevent oxidation of the Cu(I) catalyst.[4]
 - **Reducing Agents:** If using a Cu(II) precursor, ensure you have an appropriate reducing agent, such as sodium ascorbate, in your reaction mixture.
 - **Catalyst Choice:** Consider using a more stable, pre-formed Cu(I) catalyst or a ligand that can stabilize the Cu(I) oxidation state.
- **Starting Material Quality:** The purity of your starting materials, such as nitriles, amidines, or hydroxylamine, is crucial. Impurities can poison the catalyst or lead to unwanted side reactions.
 - **Troubleshooting Steps:**
 - **Purity Check:** Verify the purity of your starting materials using appropriate analytical techniques (e.g., NMR, GC-MS).
 - **Purification:** Purify starting materials if necessary. For example, distill liquid reagents and recrystallize solid reagents.
- **Sub-optimal Reaction Conditions:** Temperature, solvent, and base are critical parameters that can significantly impact the reaction outcome.
 - **Troubleshooting Steps:**

- **Temperature Screening:** The optimal temperature can be substrate-dependent. A systematic screening of the reaction temperature is advisable. Some reactions proceed well at room temperature, while others require elevated temperatures.[1][5]
- **Solvent Selection:** The choice of solvent can influence the solubility of reagents and the stability of the catalyst. Common solvents include DMSO, DMF, and t-BuOH.[3][6] It's important to use anhydrous solvents, as water can sometimes interfere with the reaction.
- **Base Optimization:** The choice and amount of base (e.g., K_3PO_4 , Cs_2CO_3) can be critical.[4][7] An inappropriate base can lead to side reactions or incomplete conversion. A screening of different bases may be necessary.

Issue 2: Formation of Significant Side Products

Question: My reaction is producing the desired 1,2,4-triazole, but I'm also observing significant amounts of side products. What are these side products and how can I minimize their formation?

Answer: The formation of side products is a common issue and can often be attributed to the reactivity of the starting materials and intermediates.

- **Homocoupling of Starting Materials:** In some cases, starting materials can undergo homocoupling reactions, leading to undesired dimers or polymers. This is particularly relevant in reactions involving terminal alkynes in the synthesis of 1,2,3-triazoles, a related class of compounds often synthesized via copper catalysis.
 - **Troubleshooting Steps:**
 - **Ligand Addition:** The use of appropriate ligands can often suppress side reactions by stabilizing the copper catalyst and modulating its reactivity. Nitrogen-based ligands are commonly employed.[3]
 - **Controlled Addition:** A slow, controlled addition of one of the reactants can sometimes minimize its homocoupling by keeping its instantaneous concentration low.

- Formation of Isomeric Products: Depending on the specific synthetic route, the formation of regioisomers is a possibility. For instance, in the synthesis of disubstituted 1,2,4-triazoles, different isomers can be formed depending on which nitrogen atom of an intermediate attacks a nitrile.[1][4]
 - Troubleshooting Steps:
 - Catalyst/Ligand System: The choice of the copper catalyst and ligand system can have a profound impact on the regioselectivity of the reaction.[1][4] A thorough literature search for your specific substrate class for recommended catalyst systems is advised.
 - Reaction Conditions: Temperature and solvent can also influence the isomeric ratio. A systematic optimization of these parameters may be required.

Issue 3: Difficulty with Product Purification

Question: I am having trouble purifying my 1,2,4-triazole product from the reaction mixture. What are the common impurities and what are the best purification strategies?

Answer: Purification challenges often arise from residual copper catalyst, inorganic salts from the base, and polar side products.

- Removal of Copper Catalyst: Copper salts can be notoriously difficult to remove completely, especially if your product has chelating moieties.
 - Troubleshooting Steps:
 - Aqueous Wash: A common method is to wash the organic extract with an aqueous solution of a chelating agent like EDTA or a dilute ammonium hydroxide solution.
 - Filtration through Silica Gel: Passing the crude product through a short plug of silica gel can effectively remove a significant portion of the copper salts.
 - Use of Heterogeneous Catalysts: Employing a supported copper catalyst that can be easily filtered off at the end of the reaction can simplify purification significantly.[7]
- Removal of Inorganic Salts: Bases like K_3PO_4 and Cs_2CO_3 are often used in these reactions and need to be removed.

- Troubleshooting Steps:
 - Aqueous Workup: A standard aqueous workup where the reaction mixture is partitioned between an organic solvent and water is usually effective in removing these salts.
 - Filtration: If the salt is not soluble in the reaction solvent, it can be removed by filtration before workup.
- Separation from Polar Side Products: The formation of polar side products can make chromatographic purification challenging.
 - Troubleshooting Steps:
 - Recrystallization: If your product is a solid, recrystallization can be a highly effective purification method.
 - Chromatography Optimization: A systematic screening of different solvent systems for column chromatography is recommended. Sometimes, the addition of a small amount of a polar solvent like methanol or a base like triethylamine to the eluent can improve separation.

General Experimental Protocol: Copper-Catalyzed Synthesis of 3,5-Disubstituted-1,2,4-Triazoles from Nitriles and Amidines

This protocol is a general guideline and may require optimization for specific substrates.

- Reaction Setup: To an oven-dried Schlenk tube, add the amidine hydrochloride (1.0 mmol), the nitrile (1.2 mmol), Cu(I) catalyst (e.g., CuI, 5 mol%), a ligand (if necessary, 10 mol%), and a base (e.g., K₃PO₄, 2.0 mmol).
- Inert Atmosphere: Evacuate and backfill the Schlenk tube with an inert gas (e.g., argon or nitrogen) three times.
- Solvent Addition: Add anhydrous solvent (e.g., DMSO, 3 mL) via syringe.

- **Reaction:** Stir the reaction mixture at the desired temperature (e.g., 120 °C) for the specified time (e.g., 12-24 hours). Monitor the reaction progress by TLC or LC-MS.
- **Workup:** After the reaction is complete, cool the mixture to room temperature. Dilute with an organic solvent (e.g., ethyl acetate) and wash with water and brine.
- **Purification:** Dry the organic layer over anhydrous Na_2SO_4 , filter, and concentrate under reduced pressure. Purify the crude product by column chromatography on silica gel or by recrystallization.

Visualizing the Process

Reaction Mechanism

The following diagram illustrates a plausible catalytic cycle for the copper-catalyzed synthesis of a 1,2,4-triazole from an amidine and a nitrile.

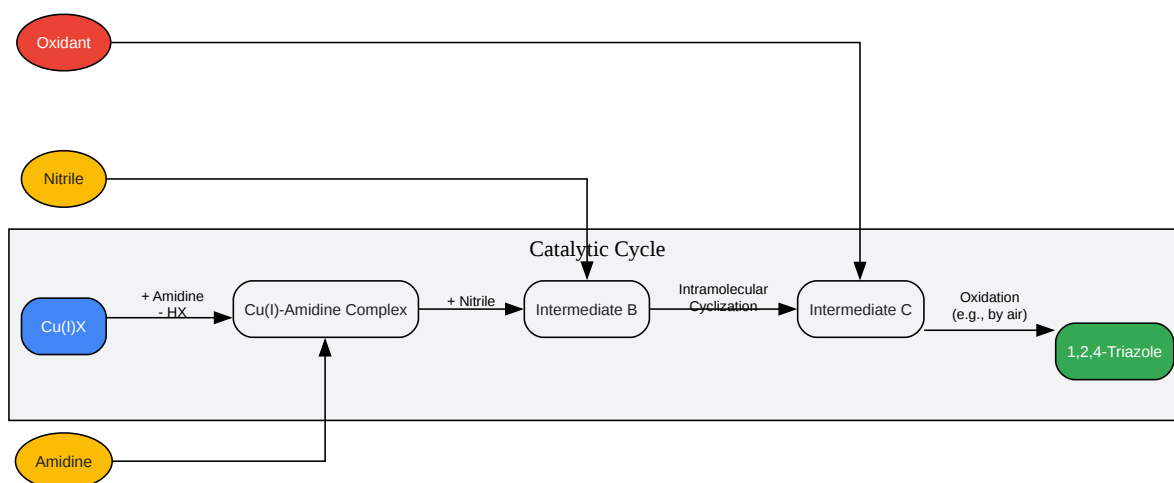

[Click to download full resolution via product page](#)

Caption: Plausible catalytic cycle for 1,2,4-triazole synthesis.

Troubleshooting Workflow

This workflow provides a logical sequence of steps to diagnose and resolve common issues in your synthesis.

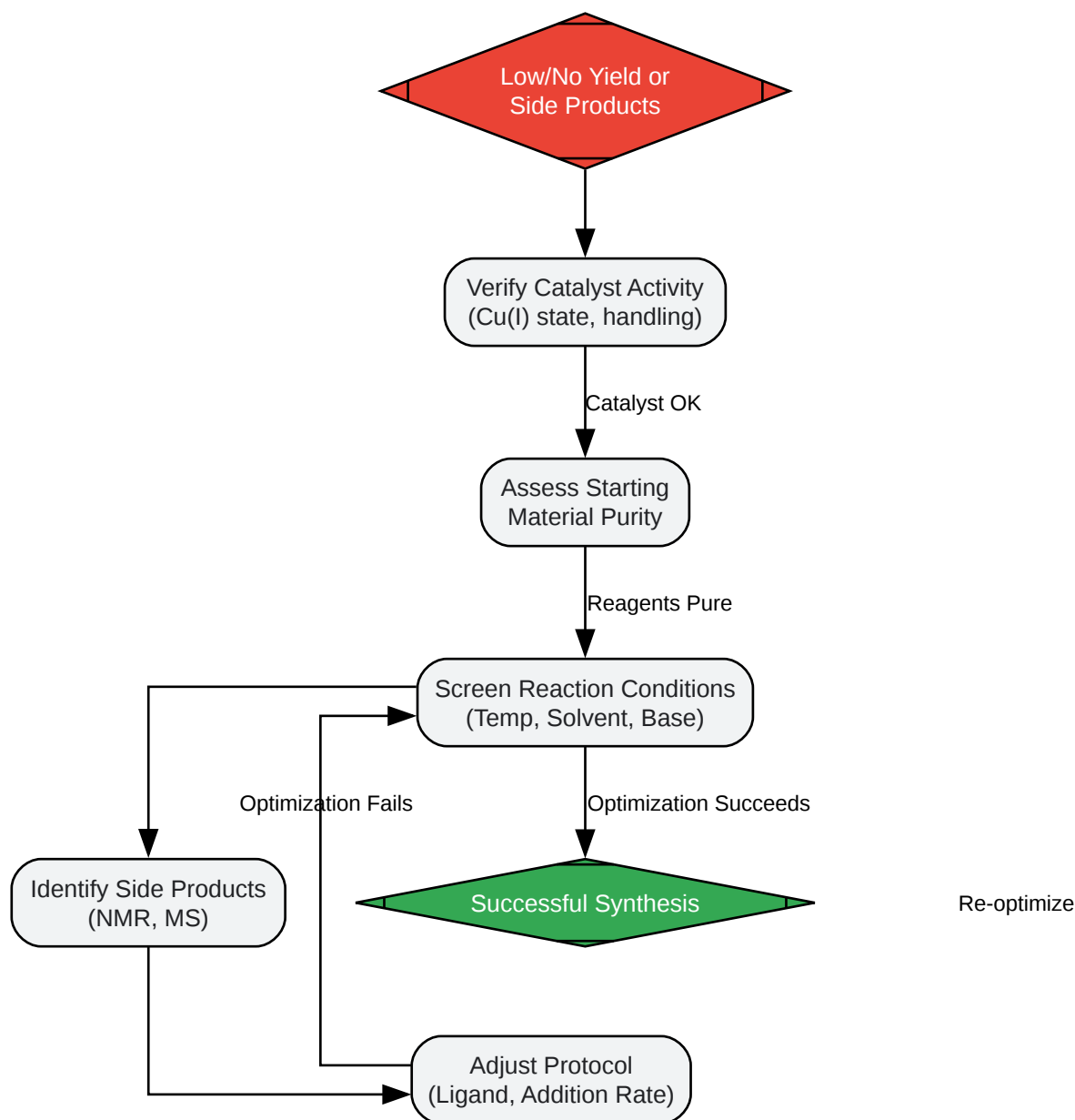

[Click to download full resolution via product page](#)

Need Custom Synthesis?

BenchChem offers custom synthesis for rare earth carbides and specific isotopic labeling.

Email: info@benchchem.com or [Request Quote Online](#).

Sources

- [1. Synthesis methods of 1,2,3-/1,2,4-triazoles: A review - PMC \[pmc.ncbi.nlm.nih.gov\]](#)
- [2. mdpi.com \[mdpi.com\]](#)
- [3. Azide-alkyne Huisgen cycloaddition - Wikipedia \[en.wikipedia.org\]](#)
- [4. isres.org \[isres.org\]](#)
- [5. Frontiers | Synthesis methods of 1,2,3-/1,2,4-triazoles: A review \[frontiersin.org\]](#)
- [6. pubs.acs.org \[pubs.acs.org\]](#)
- [7. 1H-1,2,4-Triazole synthesis \[organic-chemistry.org\]](#)
- To cite this document: BenchChem. [Technical Support Center: Copper-Catalyzed 1,2,4-Triazole Synthesis]. BenchChem, [2026]. [Online PDF]. Available at: [\[https://www.benchchem.com/product/b596783/docs#technical-support-center-copper-catalyzed-1-2-4-triazole-synthesis\]](https://www.benchchem.com/product/b596783/docs#technical-support-center-copper-catalyzed-1-2-4-triazole-synthesis)

Disclaimer & Data Validity:

The information provided in this document is for Research Use Only (RUO) and is strictly not intended for diagnostic or therapeutic procedures. While BenchChem strives to provide accurate protocols, we make no warranties, express or implied, regarding the fitness of this product for every specific experimental setup.

Technical Support: The protocols provided are for reference purposes. Unsure if this reagent suits your experiment?

Need Industrial/Bulk Grade? [Request Custom Synthesis Quote](#)

BenchChem

Our mission is to be the trusted global source of essential and advanced chemicals, empowering scientists and researchers to drive progress in science and industry.

Contact

Address: 3281 E Guasti Rd
Ontario, CA 91761, United States
Phone: (601) 213-4426
Email: info@benchchem.com

Contact our Ph.D. Support Team for a compatibility check