

Technical Support Center: Optimizing 5-Bromo-2-piperidinopyridine, HCl Synthesis

Author: BenchChem Technical Support Team. **Date:** May 2026

Compound of Interest

Compound Name: 5-Bromo-2-piperidinopyridine, hcl

CAS No.: 1242336-67-9

Cat. No.: B594506

[Get Quote](#)

Status: Active Last Updated: February 8, 2026 Topic: Reaction Optimization & Troubleshooting
Target Molecule: 5-Bromo-2-(piperidin-1-yl)pyridine hydrochloride CAS (Free Base): 73406-97-0^[1]

Introduction: The Application Scientist's Perspective

Welcome to the technical guide for synthesizing **5-Bromo-2-piperidinopyridine, HCl**. This molecule is a critical "building block" in medicinal chemistry, often serving as a precursor for Suzuki-Miyaura couplings (via the 5-bromo handle) or as a core scaffold in GPCR ligand design.

The synthesis relies on a Nucleophilic Aromatic Substitution (

)[2][3] While seemingly straightforward, the reaction is governed by strict electronic rules regarding regioselectivity. The 2-position of the pyridine ring is activated for nucleophilic attack, while the 5-position is deactivated. Success depends on exploiting this kinetic difference to prevent bis-substitution while driving the reaction to completion.

This guide moves beyond "recipe" chemistry to provide a mechanistic understanding, optimized protocols, and a logic-based troubleshooting framework.

Module 1: Mechanistic Insight & Regioselectivity

The Core Challenge: C2 vs. C5 Selectivity

The starting material, 2,5-dibromopyridine, possesses two electrophilic sites. However, they are not equal.[2]

- C2 Position (Ortho-like): Highly reactive. The ring nitrogen is electron-withdrawing, stabilizing the negative charge in the transition state (Meisenheimer complex).
- C5 Position (Meta-like): Unreactive. It lacks the ability to delocalize the negative charge onto the electronegative nitrogen during the intermediate step.[4]

Key Takeaway: Under standard thermal conditions (

C), the reaction is highly regioselective for the C2 position. Bis-substitution (reaction at both C2 and C5) is rare unless extreme forcing conditions (high pressure/temp, Cu-catalysis) are applied.

Reaction Pathway Diagram

The following diagram illustrates the kinetic pathway and the critical salt formation step.

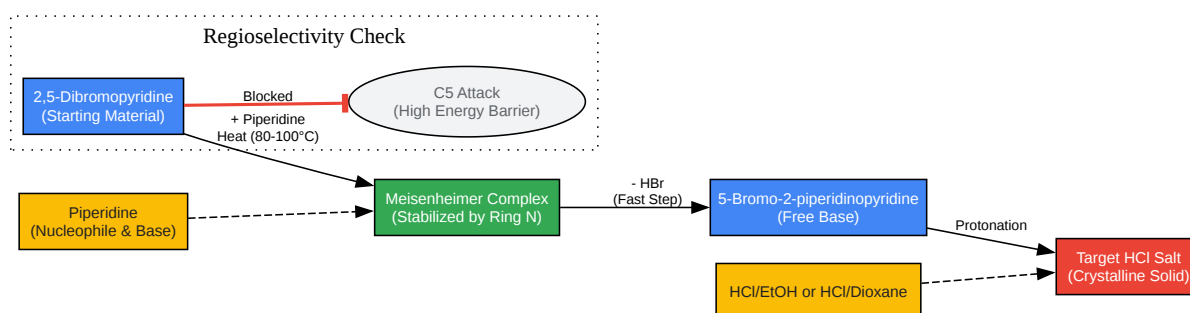

[Click to download full resolution via product page](#)

Figure 1: Reaction pathway demonstrating the selective mechanism at the C2 position and subsequent salt formation.[5]

Module 2: Optimized Experimental Protocols

Two methods are presented. Method A (Neat) is preferred for robustness and kinetics. Method B (Solvent) is preferred if stoichiometry must be strictly controlled or for larger scale-ups where heat dissipation is a concern.

Method A: The "Neat" Protocol (Recommended)

Best for: Gram-scale synthesis, high conversion rates.

Parameter	Specification	Rationale
Stoichiometry	1.0 equiv 2,5-dibromopyridine : 4.0–5.0 equiv Piperidine	Excess piperidine acts as both the nucleophile and the base to scavenge HBr.
Solvent	None (Neat Piperidine)	Maximizes concentration, increasing reaction rate ().
Temperature	90°C – 100°C	Sufficient activation energy for without promoting degradation.
Time	4 – 12 Hours	Monitor by TLC/LCMS.

Step-by-Step:

- Charge: Place 2,5-dibromopyridine (e.g., 5.0 g) in a round-bottom flask equipped with a magnetic stir bar and reflux condenser.
- Add Nucleophile: Add piperidine (approx. 10 mL / 5 equiv). The solid should dissolve upon slight warming.

- Reaction: Heat the mixture to 100°C. The solution will likely turn yellow/orange.
- Monitor: Check LCMS after 4 hours. Look for mass $[M+H]^+ = 241/243$ (Br isotope pattern).
- Workup:
 - Cool to room temperature.
 - Pour into water (50 mL) and extract with Ethyl Acetate (3 x 30 mL).
 - Wash combined organics with water (to remove excess piperidine) and brine.
 - Dry over

, filter, and concentrate to an oil/solid (Free Base).

Method B: Salt Formation (The HCl Step)

Crucial for stability. The free base can be an oil or low-melting solid; the HCl salt is a stable crystalline solid.

- Dissolution: Dissolve the crude free base (from Method A) in a minimum amount of Ethanol (EtOH) or Isopropanol (IPA) at room temperature.
- Acidification: Slowly add 4M HCl in Dioxane (1.1 equiv) or concentrated aqueous HCl dropwise.
 - Note: An exotherm is expected.[\[2\]](#)
- Crystallization:
 - If precipitate forms immediately: Stir for 30 mins, then filter.
 - If no precipitate: Add Diethyl Ether or MTBE as an anti-solvent until cloudy. Cool to 0°C.
- Isolation: Filter the white/off-white solid. Wash with cold ether. Dry under vacuum.

Module 3: Troubleshooting Guide (FAQ)

Q1: The reaction is stalling (50% conversion) even after 24 hours.

Diagnosis: Product inhibition or insufficient temperature.

- Fix 1 (Temperature): If running in a solvent (like Ethanol), the reflux temp (78°C) might be too low. Switch to the Neat method or use DMF (100°C).
- Fix 2 (Base): As the reaction progresses, HBr is generated. If you only used 1-2 equiv of piperidine, the HBr protonates the remaining piperidine, killing its nucleophilicity. Ensure you have >3 equiv of piperidine or add an auxiliary base like

Q2: My product is a sticky gum, not a solid.

Diagnosis: Trapped solvent or excess piperidine.

- Fix: The free base is often an oil. Do not try to crystallize the free base if it resists. Proceed directly to the HCl salt formation.
- Salt Issue: If the salt is gummy, it likely contains trapped water or excess acid. Triturate (grind under solvent) with diethyl ether or acetone to induce crystallization.

Q3: I see a small impurity at $[M+H]^+$ ~248.

Diagnosis: This is likely the bis-substituted byproduct (2,5-dipiperidinopyridine).

- Cause: Temperature too high (>140°C) or reaction time too long (>24h).
- Remedy: This impurity is difficult to remove by crystallization. Purify the free base by column chromatography (Hexane/EtOAc) before making the salt. The bis-product is much more polar than the mono-product.

Module 4: Diagnostic Logic Tree

Use this flow to diagnose yield or purity issues.

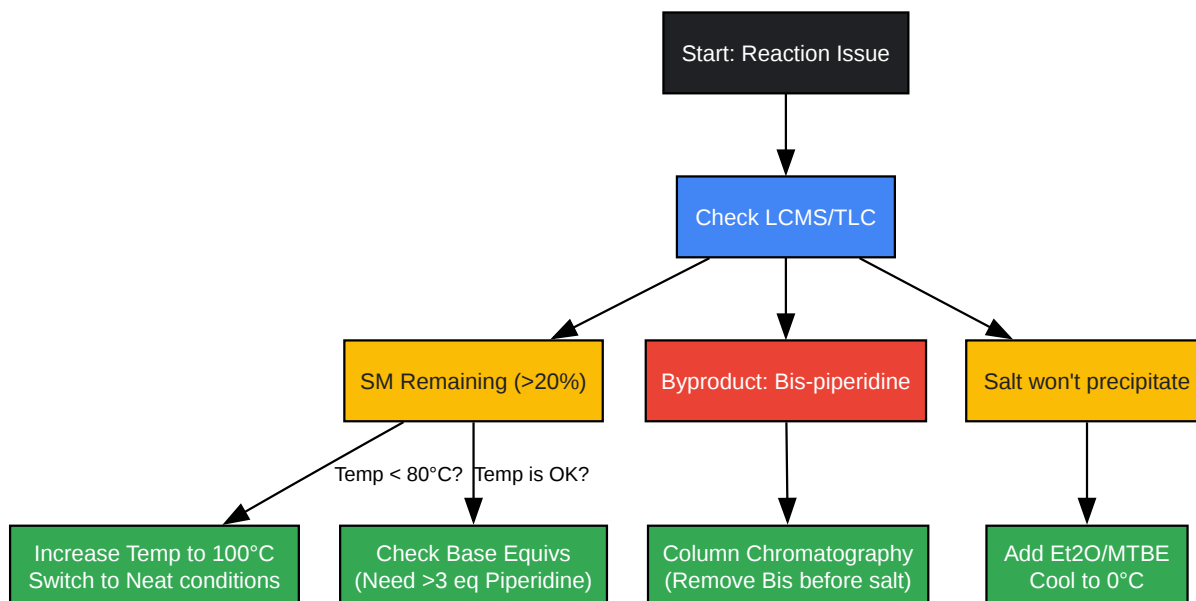

[Click to download full resolution via product page](#)

Figure 2: Troubleshooting logic for common synthesis and isolation issues.

References

- Regioselectivity of
on Dihalopyridines:
 - Title: Reactivity in the Nucleophilic Aromatic Substitution Reactions of Pyridinium Ions.[4]
[6][7][8]
 - Source: National Institutes of Health (NIH) / PubMed.
 - URL:[[Link](#)] (General principle verification).
- Synthesis of 2,5-Dibromopyridine Derivatives: Title: Synthesis of 5-bromo-2-iodopyridine from 2,5-dibromopyridine (Methodology reference). Source: ChemicalBook / Synthesis Journal.
- General

Troubleshooting:

- Title: Overcoming Product Inhibition in a Nucleophilic Aromatic Substitution Reaction.[3]
- Source: Organic Letters (ACS Public
- URL:[[Link](#)]
- Safety Data & Handling
 - Title: 5-Bromo-2-(piperidin-1-yl)
 - Source: PubChem / Chemical Vendors.[9][10][11]
 - URL:[[Link](#)]

Disclaimer: This guide is for research purposes only. Always consult the Safety Data Sheet (SDS) for 2,5-dibromopyridine and piperidine before handling. Piperidine is a precursor and may be regulated in some jurisdictions.

Need Custom Synthesis?

BenchChem offers custom synthesis for rare earth carbides and specific isotopic labeling.

Email: info@benchchem.com or [Request Quote Online](#).

Sources

- [1. 5-BROMO-2-\(PIPERAZIN-1-YL\)PYRIDINE | 73406-97-0 \[chemicalbook.com\]](#)
- [2. reddit.com \[reddit.com\]](#)
- [3. Overcoming Product Inhibition in a Nucleophilic Aromatic Substitution Reaction - PubMed \[pubmed.ncbi.nlm.nih.gov\]](#)
- [4. m.youtube.com \[m.youtube.com\]](#)
- [5. Understanding the highly variable Regioselectivity in S_NAr reaction of Dichloropyrimidines - RCS Research Chemistry Services \[rcs.wuxiapptec.com\]](#)
- [6. researchgate.net \[researchgate.net\]](#)

- [7. Reactivity in the Nucleophilic Aromatic Substitution Reactions of Pyridinium Ions - PMC \[pmc.ncbi.nlm.nih.gov\]](#)
- [8. researchgate.net \[researchgate.net\]](#)
- [9. 2-Amino-5-bromopyridine | C₅H₅BrN₂ | CID 70622 - PubChem \[pubchem.ncbi.nlm.nih.gov\]](#)
- [10. 5-Bromo-2-ethylpyridine | C₇H₈BrN | CID 13979736 - PubChem \[pubchem.ncbi.nlm.nih.gov\]](#)
- [11. \(5-Bromopyridin-2-yl\)methanol | C₆H₆BrNO | CID 5200169 - PubChem \[pubchem.ncbi.nlm.nih.gov\]](#)
- To cite this document: BenchChem. [Technical Support Center: Optimizing 5-Bromo-2-piperidinopyridine, HCl Synthesis]. BenchChem, [2026]. [Online PDF]. Available at: [<https://www.benchchem.com/product/b594506/docs#technical-support-center-optimizing-5-bromo-2-piperidinopyridine-hcl-synthesis>]

Disclaimer & Data Validity:

The information provided in this document is for Research Use Only (RUO) and is strictly not intended for diagnostic or therapeutic procedures. While BenchChem strives to provide accurate protocols, we make no warranties, express or implied, regarding the fitness of this product for every specific experimental setup.

Technical Support: The protocols provided are for reference purposes. Unsure if this reagent suits your experiment?

Need Industrial/Bulk Grade? [Request Custom Synthesis Quote](#)

BenchChem

Our mission is to be the trusted global source of essential and advanced chemicals, empowering scientists and researchers to drive progress in science and industry.

Contact

Address: 3281 E Guasti Rd

Ontario, CA 91761, United States

Phone: (601) 213-4426

Email: info@benchchem.com

Contact our Ph.D. Support Team for a compatibility check