

Technical Guide: Troubleshooting Unexpected Transformations of Brominated Pyrazolopyrimidines

Author: BenchChem Technical Support Team. **Date:** February 2026

Compound of Interest

Compound Name:	3-Bromo-7-(furan-2-yl)-2,5-dimethylpyrazolo[1,5-a]pyrimidine
CAS No.:	1263285-84-2
Cat. No.:	B594834

[Get Quote](#)

Introduction

Pyrazolo[1,5-a]pyrimidines are privileged scaffolds in kinase inhibitor discovery (e.g., inhibitors of CK2, Pim-1, and B-Raf).[1] However, their fused 5,6-membered ring system possesses a "schizophrenic" electronic character—an electron-rich pyrazole fused to an electron-deficient pyrimidine. This duality leads to non-intuitive reactivity patterns, particularly when bromine handles are present.

This guide addresses the three most critical "silent failures" reported in high-throughput optimization: Protodebromination, Regioselectivity Inversion, and Scaffold Rearrangement.

Part 1: Metal-Catalyzed Cross-Coupling Issues

Q1: Why is my Suzuki coupling yielding the debrominated product (H-scaffold) instead of the coupled product?

The Issue: You attempt a Suzuki-Miyaura coupling on a 3-bromo-pyrazolo[1,5-a]pyrimidine, but the major product is the protonated parent scaffold (up to 90% yield), with little to no desired biaryl formation.

The Mechanism: This is Protodebromination, often driven by a "Pd-hydride" pathway. The electron-deficient nature of the pyrimidine ring makes the oxidative addition complex unstable. If the reaction contains a proton source (like water in aqueous bases) or if

-hydride elimination is possible from the ligand or solvent, the palladium center reduces the aryl bromide rather than coupling it.

- Key Insight: In 7-trifluoromethyl-substituted scaffolds, the electron-withdrawing effect exacerbates this, making the C-Br bond highly labile but the intermediate Pd-Ar species prone to reduction.

Troubleshooting Protocol:

Variable	Recommendation	Scientific Rationale
Catalyst System	Switch to XPhos Pd G2 or Pd(dtbpf)Cl ₂	Bulky, electron-rich biaryl phosphine ligands facilitate rapid reductive elimination, outcompeting the protodebromination pathway.
Base	Use Anhydrous K ₃ PO ₄ or Cs ₂ CO ₃	Switch from aqueous Na ₂ CO ₃ to anhydrous conditions to remove the primary proton source.
Solvent	1,4-Dioxane or Toluene (Dry)	Avoid alcohols (MeOH/EtOH) which act as hydride donors.

Self-Validating Check: Run a test reaction with deuterated solvent (e.g.,

as a spike). If the product incorporates deuterium at the bromine position, your mechanism is solvent-mediated reduction.

Q2: In 2,6-dibromopyrazolo[1,5-a]pyrimidines, why does the coupling occur at C6 instead of the typically more reactive C2 or C3 positions?

The Issue: Standard heterocyclic intuition suggests that positions alpha to nitrogen (like C2) or electron-rich positions (C3) should react first. However, in 2,6-dibromo systems, the C6 position is frequently the first to undergo oxidative addition.

The Mechanism: This is controlled by Distortion/Interaction Theory.

- **Electronic Factor:** The C6 position in the pyrimidine ring is electronically distinct. While C3 is nucleophilic (susceptible to electrophilic aromatic substitution), C6 is part of the electron-deficient pyrimidine ring.
- **Bond Strength:** The C-Br bond at C6 is often weaker due to the specific orbital coefficients of the LUMO in the fused system.
- **Experimental Evidence:** Studies on ethyl 2,6-dibromopyrazolo[1,5-a]pyrimidine-3-carboxylate confirm exclusive C6 selectivity during Suzuki coupling.^[2]

Visual Logic: Regioselectivity Decision Tree

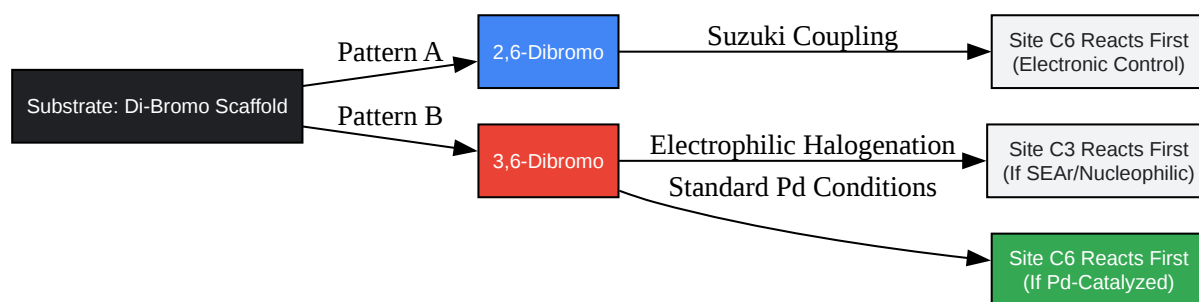

[Click to download full resolution via product page](#)

Caption: Decision flow for predicting reactive sites in di-brominated pyrazolo[1,5-a]pyrimidines.

Part 2: Nucleophilic Substitution & Rearrangement

Q3: My scaffold disappeared during base treatment and formed a new isomer. What happened?

The Issue: You treated a 7-aryl-3-formylpyrazolo[1,5-a]pyrimidine with aqueous NaOH (e.g., for hydrolysis), but the product isolated has a different NMR profile (e.g., a new NH signal).

The Mechanism: You have triggered the ANRORC (Addition of the Nucleophile, Ring Opening, and Ring Closing) mechanism.

- Attack: Hydroxide attacks the electron-deficient C5 or C7 position.
- Opening: The pyrimidine ring opens, breaking the N-C bond.
- Recyclization: The molecule rotates and recyclizes to form a Pyrazolo[3,4-b]pyridine. This is a thermodynamic sink, converting the [1,5-a]pyrimidine into the more stable [3,4-b]pyridine isomer under forcing basic conditions.

Prevention Protocol:

- Avoid: Refluxing in aqueous NaOH/KOH.
- Alternative: Use LiOH in THF/Water at room temperature for ester hydrolysis.
- Detection: Look for the appearance of a broad NH singlet (12-14 ppm) in NMR, characteristic of the pyridine nitrogen proton in the rearranged product.

Part 3: Lithiation Challenges

Q4: I tried to lithiate 3-bromo-5,7-dimethylpyrazolo[1,5-a]pyrimidine, but I got a mixture of alkylated products.

The Issue: Instead of clean Lithium-Halogen Exchange (Li-Br exchange) at C3, you observe alkylation on the methyl groups.

The Mechanism: Lateral Lithiation vs. Halogen Exchange. The protons on the 5,7-methyl groups are significantly acidic due to the electron-withdrawing nature of the pyrimidine ring (analogous to 2-picoline).

-Butyllithium is a strong enough base to deprotonate these methyl groups faster or competitively with the Br-Li exchange, especially at temperatures above -78°C.

Corrective Workflow:

- Temperature is Critical: You must cool the reaction to -100°C (using liquid /ether bath) or strictly -78°C .
- Reagent Order: Add the -BuLi to the bromide very slowly.
- Alternative: Use -BuLi (2 equivalents).

-BuLi undergoes halogen exchange much faster than it acts as a base for deprotonation, kinetically favoring the C3-Li species.

Summary of Reactivity Profiles

Reaction Type	Reactive Site	Dominant Mechanism	Critical Control Factor
Electrophilic Subst.	C3		Electron density of pyrazole ring.
Suzuki Coupling	C6 (in 2,6-diBr)	Oxidative Addition	Distortion energy of C-Br bond.
Nucleophilic Attack	C5 / C7	/ ANRORC	Steric access & leaving group ability.
Deprotonation	5,7-Methyls	Lateral Lithiation	Acidity of -protons (pKa \sim 20).

References

- Unexpected Transformations with n-BuLi: Title: Unexpected transformations of 3-bromo-5,7-dimethylpyrazolo[1,5-a]pyrimidine in reactions with BunLi.[3] Source: ResearchGate / Russian Journal of Organic Chemistry. URL:[[Link](#)]

- Protodebromination Issues: Title: Efficient microwave-assisted Suzuki–Miyaura cross-coupling reaction of 3-bromo pyrazolo[1,5-a]pyrimidin-5(4H)-one.[4] Source: PubMed Central (PMC). URL:[[Link](#)]
- Ring Rearrangement (ANRORC): Title: Isomerization of pyrazolopyrimidines to pyrazolopyridines by ring-opening/closing reaction in aqueous NaOH.[5] Source: Royal Society of Chemistry (RSC) Advances. URL:[[Link](#)]

Need Custom Synthesis?

BenchChem offers custom synthesis for rare earth carbides and specific isotopic labeling.

Email: info@benchchem.com or [Request Quote Online](#).

Sources

- [1. Advances in pyrazolo\[1,5-a\]pyrimidines: synthesis and their role as protein kinase inhibitors in cancer treatment - PMC \[pmc.ncbi.nlm.nih.gov\]](#)
- [2. Thieme E-Journals - Synthesis / Abstract \[thieme-connect.com\]](#)
- [3. researchgate.net \[researchgate.net\]](#)
- [4. Efficient microwave-assisted Suzuki-Miyaura cross-coupling reaction of 3-bromo pyrazolo\[1,5- a\]pyrimidin-5\(4 H\)-one: towards a new access to 3,5-diarylated 7-\(trifluoromethyl\)pyrazolo\[1,5- a\]pyrimidine derivatives - PubMed \[pubmed.ncbi.nlm.nih.gov\]](#)
- [5. Isomerization of pirazolopyrimidines to pyrazolopyridines by ring-opening/closing reaction in aqueous NaOH - RSC Advances \(RSC Publishing\) \[pubs.rsc.org\]](#)
- To cite this document: BenchChem. [Technical Guide: Troubleshooting Unexpected Transformations of Brominated Pyrazolopyrimidines]. BenchChem, [2026]. [Online PDF]. Available at: [<https://www.benchchem.com/product/b594834#troubleshooting-unexpected-transformations-of-brominated-pyrazolopyrimidines>]

Disclaimer & Data Validity:

The information provided in this document is for Research Use Only (RUO) and is strictly not intended for diagnostic or therapeutic procedures. While BenchChem strives to provide

accurate protocols, we make no warranties, express or implied, regarding the fitness of this product for every specific experimental setup.

Technical Support: The protocols provided are for reference purposes. Unsure if this reagent suits your experiment? [[Contact our Ph.D. Support Team for a compatibility check](#)]

Need Industrial/Bulk Grade? [Request Custom Synthesis Quote](#)

BenchChem

Our mission is to be the trusted global source of essential and advanced chemicals, empowering scientists and researchers to drive progress in science and industry.

Contact

Address: 3281 E Guasti Rd

Ontario, CA 91761, United States

Phone: (601) 213-4426

Email: info@benchchem.com