

Application Notes: Immunofluorescence Staining for Tie2 in HUVECs

Author: BenchChem Technical Support Team. **Date:** April 2026

Compound of Interest

Compound Name: *Tie2 kinase inhibitor 2*

Cat. No.: *B593661*

[Get Quote](#)

These application notes provide detailed protocols and supporting information for the immunofluorescent detection of the Tie2 receptor in Human Umbilical Vein Endothelial Cells (HUVECs). This methodology is crucial for researchers in angiogenesis, vascular biology, and drug development to visualize Tie2 expression, localization, and modulation in response to various stimuli.

Introduction

Tie2, also known as TEK receptor tyrosine kinase, is a key regulator of vascular development, stability, and inflammation.[1][2][3] Primarily expressed on endothelial cells, its signaling is modulated by angiopoietin ligands, Angiopoietin-1 (Ang1) and Angiopoietin-2 (Ang2).[4][5] Ang1 typically acts as an agonist, promoting vascular stability, while Ang2 can act as a context-dependent antagonist or partial agonist.[4][5] Immunofluorescence is a powerful technique to study the subcellular localization of Tie2, which can translocate to cell-cell junctions upon activation, providing insights into the functional status of the endothelium.[6]

Key Experimental Considerations

- **Antibody Selection:** The choice of a primary antibody is critical for successful immunofluorescence. Both monoclonal and polyclonal antibodies against Tie2 are

commercially available. It is essential to use an antibody validated for immunofluorescence applications. For example, the mouse monoclonal antibody clone AB33 has been successfully used for Tie2 staining in HUVECs.[7]

- **Cell Culture:** HUVECs should be cultured on a suitable substrate, such as glass coverslips coated with gelatin or collagen, to ensure proper cell adhesion and morphology.[7][8]
- **Fixation and Permeabilization:** Proper fixation and permeabilization are crucial for preserving cellular structure and allowing antibody access to the target protein. 4% paraformaldehyde (PFA) is a common fixative, followed by permeabilization with a detergent like Triton X-100. [7][9][10]
- **Controls:** Appropriate controls are necessary to validate the staining results. These include a secondary antibody-only control (to check for non-specific binding of the secondary antibody) and an isotype control (to ensure the observed staining is not due to non-specific binding of the primary antibody).

Quantitative Data Summary

The following table summarizes typical quantitative parameters that can be analyzed from immunofluorescence images of Tie2 in HUVECs. The values are representative and will vary depending on experimental conditions.

Parameter	Control (Unstimulated)	Ang1 Stimulation	TNF- α Stimulation
Tie2 Mean Fluorescence Intensity (Arbitrary Units)	150 \pm 25	250 \pm 40	120 \pm 30
Tie2 Localization	Diffuse, cytoplasmic and membrane	Increased at cell-cell junctions	Reduced membrane expression
Nuclear to Cytoplasmic Ratio of Downstream Effector (e.g., FOXO1)	1.2 \pm 0.2	0.5 \pm 0.1	1.5 \pm 0.3

Experimental Protocols

I. HUVEC Culture and Preparation

- **Coating Coverslips:** Aseptically place sterile glass coverslips into the wells of a 24-well plate. Coat the coverslips with 1% gelatin and allow them to dry completely in a laminar flow hood.
- **Cell Seeding:** Seed HUVECs onto the gelatin-coated coverslips at a density that will result in a confluent monolayer after 24-48 hours of incubation.
- **Experimental Treatment:** Once the cells reach the desired confluency, perform any experimental treatments (e.g., stimulation with Ang1, TNF- α , or drug candidates).

II. Immunofluorescence Staining Protocol

- **Fixation:** Gently wash the cells twice with Phosphate Buffered Saline (PBS). Fix the cells with 4% paraformaldehyde (PFA) in PBS for 10-15 minutes at room temperature.^{[7][9][10]}
- **Washing:** Wash the cells three times with PBS for 5 minutes each.
- **Permeabilization:** Permeabilize the cells with 0.1-0.3% Triton X-100 in PBS for 10-20 minutes at room temperature.^{[7][9][10]}
- **Washing:** Wash the cells three times with PBS for 5 minutes each.
- **Blocking:** Block non-specific antibody binding by incubating the cells in a blocking buffer (e.g., 5% Bovine Serum Albumin (BSA) or 10% donkey serum in PBS) for 1 hour at room temperature.^{[7][8][9]}
- **Primary Antibody Incubation:** Dilute the primary anti-Tie2 antibody (e.g., clone AB33 at 1:100) in the blocking buffer.^[7] Incubate the cells with the primary antibody solution overnight at 4°C.
- **Washing:** Wash the cells three times with PBS for 5 minutes each.
- **Secondary Antibody Incubation:** Dilute a fluorophore-conjugated secondary antibody (e.g., Donkey anti-mouse Cy3 at 1:200) in the blocking buffer.^[7] Incubate the cells with the secondary antibody solution for 1 hour at room temperature, protected from light.

- Washing: Wash the cells three times with PBS for 5 minutes each, protected from light.
- Counterstaining (Optional): To visualize the nuclei, incubate the cells with a DNA stain like DAPI (4',6-diamidino-2-phenylindole) for 5-10 minutes.
- Washing: Perform a final wash with PBS.
- Mounting: Mount the coverslips onto microscope slides using an anti-fade mounting medium.
- Imaging: Visualize the staining using a fluorescence or confocal microscope.

Signaling Pathway and Experimental Workflow

Below are diagrams illustrating the Tie2 signaling pathway and the experimental workflow for immunofluorescence staining.

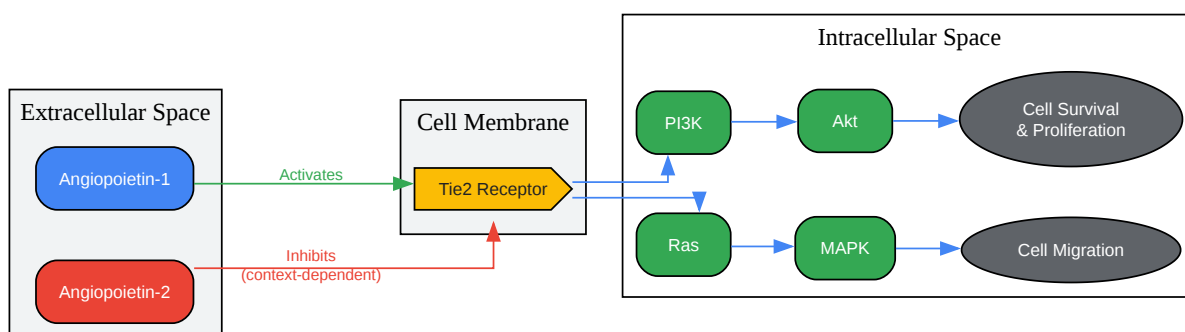

[Click to download full resolution via product page](#)

Caption: Angiopoietin-Tie2 Signaling Pathway in HUVECs.

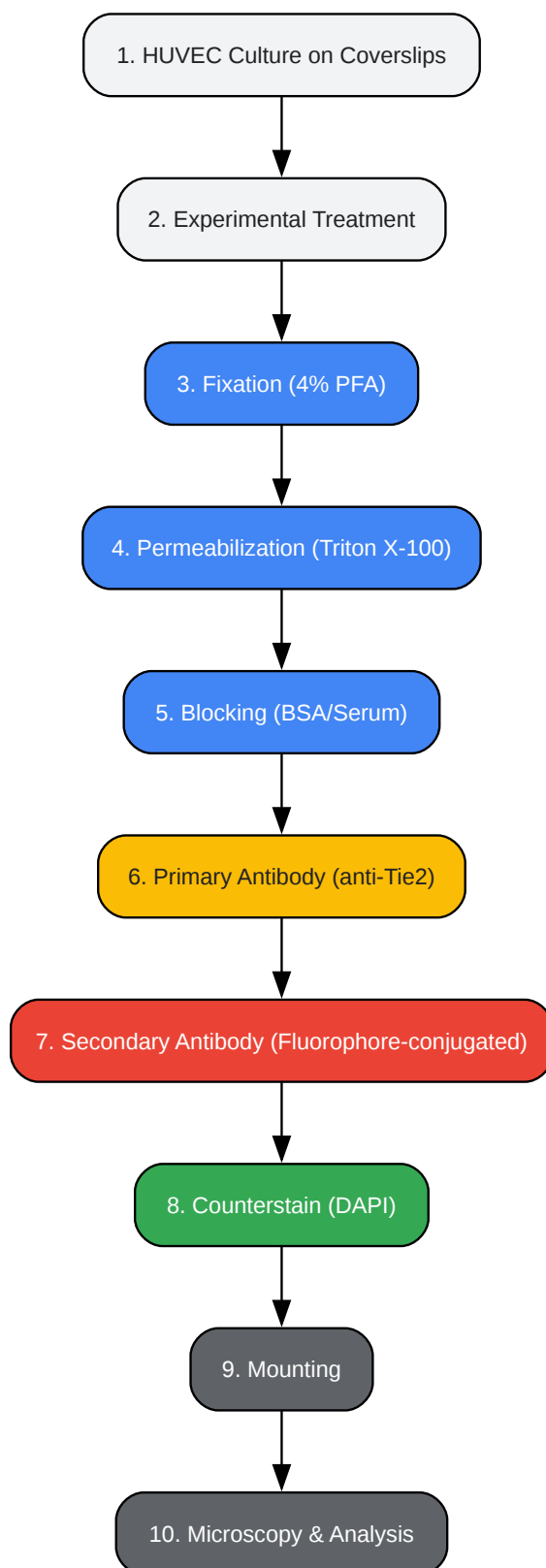

[Click to download full resolution via product page](#)

Caption: Immunofluorescence Staining Workflow for Tie2 in HUVECs.

Need Custom Synthesis?

BenchChem offers custom synthesis for rare earth carbides and specific isotopic labeling.

Email: info@benchchem.com or [Request Quote Online](#).

References

- 1. The angiotensin-Tie2 signaling axis in the vascular leakage of systemic inflammation - PMC [[pmc.ncbi.nlm.nih.gov](https://pubmed.ncbi.nlm.nih.gov/)]
- 2. The Complex Role of Angiotensin-2 in the Angiotensin-Tie Signaling Pathway - PMC [[pmc.ncbi.nlm.nih.gov](https://pubmed.ncbi.nlm.nih.gov/)]
- 3. [tandfonline.com](https://www.tandfonline.com) [[tandfonline.com](https://www.tandfonline.com)]
- 4. Angiotensin-TIE2 Signaling | Thermo Fisher Scientific - SG [[thermofisher.com](https://www.thermofisher.com)]
- 5. Tie2 (to) Abl: Signaling to endothelial cell survival - PMC [[pmc.ncbi.nlm.nih.gov](https://pubmed.ncbi.nlm.nih.gov/)]
- 6. [researchgate.net](https://www.researchgate.net) [[researchgate.net](https://www.researchgate.net)]
- 7. 4.4. Endothelial Immunofluorescence Staining [[bio-protocol.org](https://www.bio-protocol.org)]
- 8. Identification of specific Tie2 cleavage sites and therapeutic modulation in experimental sepsis - PMC [[pmc.ncbi.nlm.nih.gov](https://pubmed.ncbi.nlm.nih.gov/)]
- 9. [biossusa.com](https://www.biossusa.com) [[biossusa.com](https://www.biossusa.com)]
- 10. [sinobiological.com](https://www.sinobiological.com) [[sinobiological.com](https://www.sinobiological.com)]
- To cite this document: BenchChem. [Application Notes: Immunofluorescence Staining for Tie2 in HUVECs]. BenchChem, [2026]. [Online PDF]. Available at: [<https://www.benchchem.com/product/b593661/docs#application-notes-immunofluorescence-staining-for-tie2-in-huvecs>]

Disclaimer & Data Validity:

The information provided in this document is for Research Use Only (RUO) and is strictly not intended for diagnostic or therapeutic procedures. While BenchChem strives to provide accurate protocols, we make no warranties, express or implied, regarding the fitness of this product for every specific experimental setup.

Technical Support: The protocols provided are for reference purposes. Unsure if this reagent suits your experiment?

Need Industrial/Bulk Grade? [Request Custom Synthesis Quote](#)

BenchChem

Our mission is to be the trusted global source of essential and advanced chemicals, empowering scientists and researchers to drive progress in science and industry.

Contact

Address: 3281 E Guasti Rd
Ontario, CA 91761, United States
Phone: (601) 213-4426
Email: info@benchchem.com

[Contact our Ph.D. Support Team for a compatibility check](#)