

Understanding Isotopic Enrichment in Methyl Heptadecanoate-d3

Author: BenchChem Technical Support Team. **Date:** May 2026

Compound of Interest

Compound Name: Methyl Heptadecanoate-d3

CAS No.: 209627-97-4

Cat. No.: B592404

[Get Quote](#)

Executive Summary

Methyl heptadecanoate-d3 serves as a critical internal standard (IS) in quantitative lipidomics and gas chromatography-mass spectrometry (GC-MS). Its utility stems from a unique intersection of chemical rarity (the C17 chain is exogenous to most mammalian pathways) and isotopic distinctiveness (the deuterium label).

This guide deconstructs the technical architecture of this molecule, focusing on the ester-methyl deuteration (

) variant commonly generated during stable isotope labeling derivatization (SILD). We will explore the thermodynamics of its synthesis, the "inverse isotope effect" that governs its chromatographic behavior, and the mathematical rigor required to calculate isotopic enrichment against a background of natural abundance.

Chemical Architecture & Isotopic Physics

The Molecule

Methyl heptadecanoate-d3 is the methyl ester of heptadecanoic acid (margaric acid) where the methyl group attached to the carboxylate is fully deuterated.

- Parent Acid: Heptadecanoic Acid (C17:0).[1] Chosen because odd-chain fatty acids are rare in animal lipids, minimizing interference from endogenous analytes.
- Label Location: The methyl ester group ().
- Mass Shift: +3.018 Da relative to the unlabeled ester (M+0).

The Deuterium Isotope Effect

In GC-MS, deuterated compounds do not co-elute perfectly with their hydrogenated counterparts. They exhibit an Inverse Chromatographic Isotope Effect.

- Mechanism: The C-D bond is shorter and has a smaller molar volume than the C-H bond due to the lower zero-point vibrational energy of the heavier isotope. This reduces the London dispersion forces between the analyte and the stationary phase.
- Result: **Methyl heptadecanoate-d3** elutes slightly earlier (typically 1–3 seconds) than unlabeled methyl heptadecanoate on polar capillary columns (e.g., biscyanopropyl phases).
- Implication: Integration windows must be widened or specifically offset to capture the IS peak correctly; failing to account for this RT shift results in quantitation errors.

Synthesis & Enrichment Mechanisms[2]

The generation of **Methyl Heptadecanoate-d3** is typically achieved through acid-catalyzed esterification using Methanol-d3. This process is often performed in situ to validate extraction recovery.

Reaction Pathway (Graphviz)

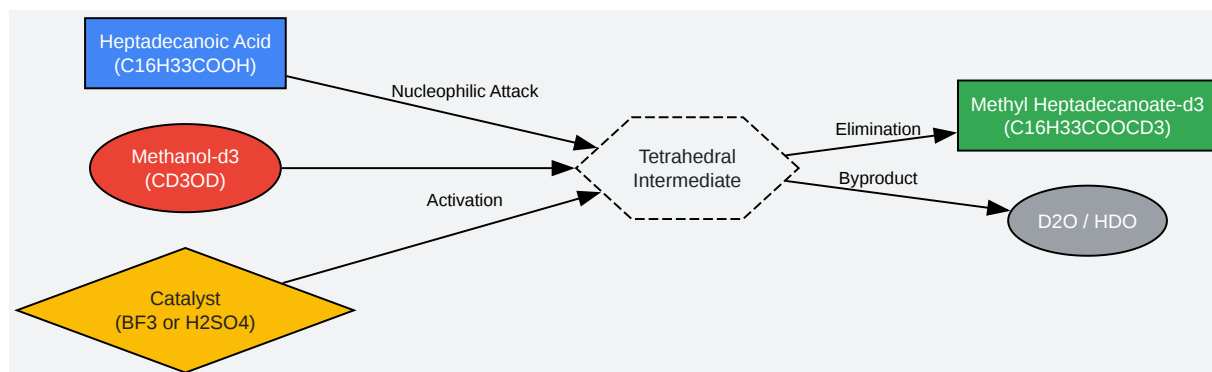

[Click to download full resolution via product page](#)

Figure 1: Acid-catalyzed esterification pathway for the synthesis of **Methyl Heptadecanoate-d₃**.

Defining Isotopic Enrichment

Enrichment is not merely "purity"; it is the statistical probability of the label's presence.

- Atom % D: The percentage of hydrogen atoms at the labeled position that are actually deuterium. High-quality Methanol-d₃ is typically >99.8 Atom % D.
- Isotopic Dilution: If reagents are exposed to atmospheric moisture (), proton exchange can occur before the reaction completes, lowering the enrichment to d₂ or d₁ species.

Analytical Validation: The GC-MS Workflow

Mass Spectral Signature

The mass spectrum of **Methyl Heptadecanoate-d₃** is distinct.

- McLafferty Rearrangement Ion: In standard FAMES, the base peak is often m/z 74. In the d₃-variant, this shifts to m/z 77 ().

- Molecular Ion: Shifts from 284 (M+0) to 287 (M+3).

Quantitation Protocol

This protocol assumes the use of **Methyl Heptadecanoate-d3** as an Internal Standard (IS) for quantifying plasma fatty acids.

Step 1: Standard Preparation

- Dissolve 10 mg **Methyl Heptadecanoate-d3** in 10 mL Hexane (1 mg/mL stock).
- Store at -20°C in a glass vial with a Teflon-lined cap to prevent solvent evaporation and concentration drift.

Step 2: Sample Spiking (The Critical Control Point)

- Spike the IS before extraction to account for lipid recovery losses.
- Target Concentration: The IS signal should be within the linear dynamic range of the instrument, ideally 50-100% of the intensity of the target analyte (e.g., Palmitic Acid).

Step 3: GC-MS Acquisition

Parameter	Setting	Rationale
Column	Biscyanopropyl (e.g., SP-2560, HP-88)	Critical for separating cis/trans isomers; maximizes the isotope RT shift.
Carrier Gas	Helium, 1.0 mL/min	Constant flow ensures reproducible RT shifts.
Inlet	Split (10:1) or Splitless	Splitless for trace analysis; Split for high-abundance plasma lipids.
MS Mode	SIM (Selected Ion Monitoring)	Monitor m/z 77 (IS Quant) and m/z 74 (Analyte Quant).
Dwell Time	25-50 ms	Sufficient points across the peak (15-20) for accurate integration.

Step 4: Data Processing (Isotopic Correction) You must correct for the natural abundance of Carbon-13 (

) in the native analytes that might overlap with the IS, although this is rare for M+3 shifts. More importantly, check for "crosstalk" if the d3-enrichment is low.

Equation for Concentration (

):

Where RF (Response Factor) is determined via a calibration curve of unlabeled standards.

Isotopic Enrichment Calculation & Quality Assurance

When validating the IS itself, you must calculate the actual enrichment to ensure no "spectral leakage" into the unlabeled channels.

Calculating Atom % Excess (APE)

Using the molecular ion cluster intensities (

):

- Measure Intensities:

(d0),

(d1),

(d2),

(d3).

- Normalize:

.

- Calculate %:

Note: A high-quality standard should be >99% d3. If d0 > 0.5%, the standard is compromised and will bias the quantitation of native C17:0.

Troubleshooting Isotopic Integrity

Issue	Symptom	Root Cause	Remediation
RT Shift Drift	d3 peak merges with d0	Column aging or phase stripping.	Trim column or replace stationary phase.
Low m/z 77 Signal	Poor sensitivity	Source contamination or incorrect ionization energy.	Clean ion source; verify 70 eV ionization.
High M+2 Signal	d2 contamination	Moisture in Methanol-d3 reagent during synthesis.	Use fresh, anhydrous reagents under .

Logical Workflow Diagram

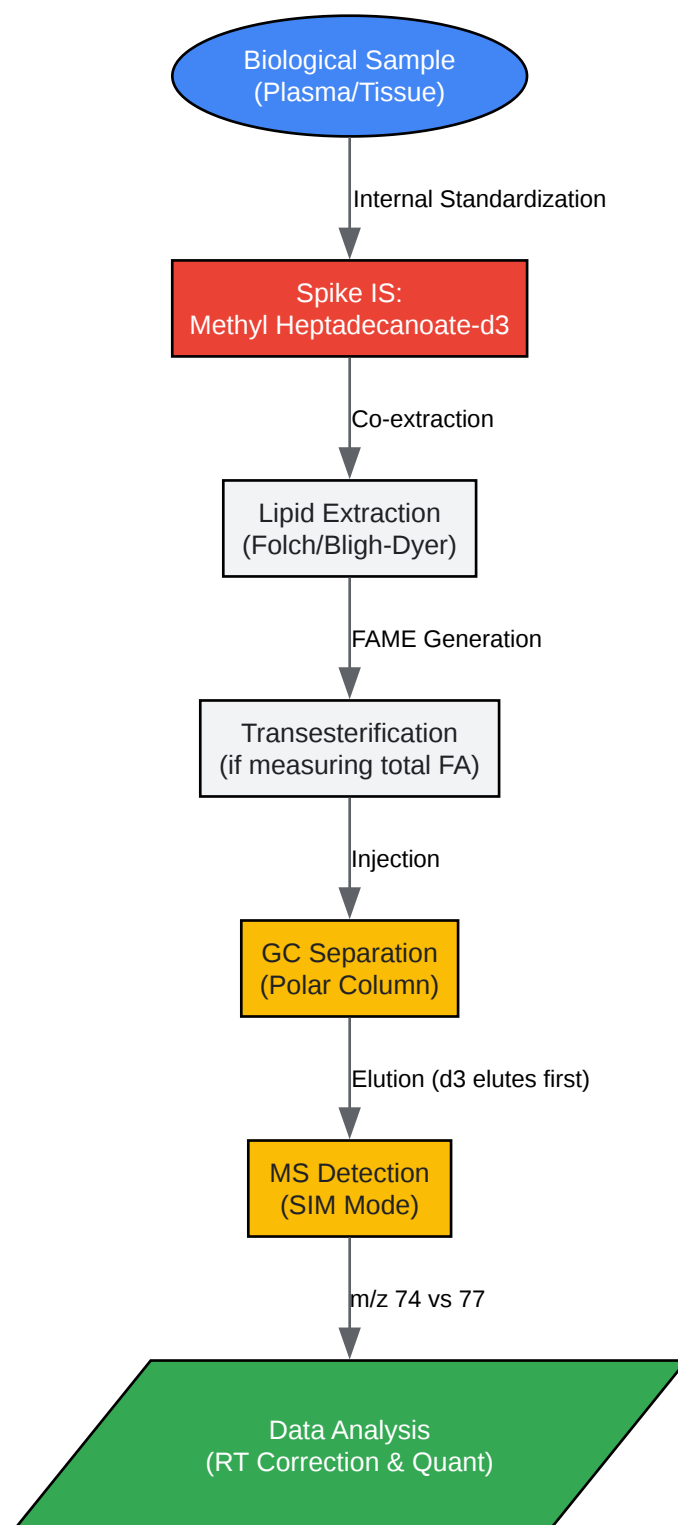

[Click to download full resolution via product page](#)

Figure 2: End-to-end analytical workflow for lipidomics using **Methyl Heptadecanoate-d3**.

References

- Thies, F., et al. (2023). Isotope-labeling in situ derivatization and HS-SPME arrow GC–MS/MS for simultaneous determination of fatty acids and fatty acid methyl esters. National Institutes of Health (PMC). [Link](#)
- Matyash, V., et al. (2008). Lipid extraction by methyl-tert-butyl ether for high-throughput lipidomics. Journal of Lipid Research. [Link](#)
- Sigma-Aldrich. **Methyl heptadecanoate-d33** Product Specification & Isotopic Purity. [Link](#)
- Tu, J., et al. (2019). Stable Isotope Labeling-Based Lipidomics. Methods in Molecular Biology. [Link](#)
- Cahoon, E. B., et al. (2012). Global analysis of the yeast lipidome by quantitative shotgun mass spectrometry. Proceedings of the National Academy of Sciences. [Link](#)

Need Custom Synthesis?

BenchChem offers custom synthesis for rare earth carbides and specific isotopic labeling.

Email: info@benchchem.com or [Request Quote Online](#).

Sources

- [1. medchemexpress.com \[medchemexpress.com\]](https://www.medchemexpress.com)
- To cite this document: BenchChem. [Understanding Isotopic Enrichment in Methyl Heptadecanoate-d3]. BenchChem, [2026]. [Online PDF]. Available at: [\[https://www.benchchem.com/product/b592404/docs#understanding-isotopic-enrichment-in-methyl-heptadecanoate-d3\]](https://www.benchchem.com/product/b592404/docs#understanding-isotopic-enrichment-in-methyl-heptadecanoate-d3)

Disclaimer & Data Validity:

The information provided in this document is for Research Use Only (RUO) and is strictly not intended for diagnostic or therapeutic procedures. While BenchChem strives to provide accurate protocols, we make no warranties, express or implied, regarding the fitness of this product for every specific experimental setup.

Technical Support: The protocols provided are for reference purposes. Unsure if this reagent suits your experiment?

Need Industrial/Bulk Grade? [Request Custom Synthesis Quote](#)

BenchChem

Our mission is to be the trusted global source of essential and advanced chemicals, empowering scientists and researchers to drive progress in science and industry.

Contact

Address: 3281 E Guasti Rd
Ontario, CA 91761, United States
Phone: (601) 213-4426
Email: info@benchchem.com

[Contact our Ph.D. Support Team for a compatibility check](#)