

Technical Support Center: Fragmentation Analysis of Ethyl-d5 2-Methylbutyrate

Author: BenchChem Technical Support Team. **Date:** May 2026

Compound of Interest

Compound Name: Ethyl-d5 2-Methylbutyrate

CAS No.: 1082581-95-0

Cat. No.: B592414

[Get Quote](#)

This guide provides a comprehensive analysis of the electron ionization (EI) mass spectrometry fragmentation patterns for **Ethyl-d5 2-Methylbutyrate**. It is designed for researchers and professionals who use this isotopically labeled compound, often as an internal standard, and require a deep understanding of its mass spectral behavior for accurate identification and troubleshooting.

Frequently Asked Questions (FAQs) & Troubleshooting

Q1: What are the primary fragment ions observed in the mass spectrum of standard (unlabeled) Ethyl 2-Methylbutyrate?

When analyzing unlabeled Ethyl 2-Methylbutyrate ($C_7H_{14}O_2$, Molecular Weight: 130.18 g/mol) by Electron Ionization Mass Spectrometry (EI-MS), several characteristic fragmentation pathways occur.[1][2] The molecular ion ($M^{+\bullet}$) is often weak or absent due to the molecule's propensity to fragment.[3] The most significant and commonly observed ions are:

- m/z 57 (Base Peak): This is the most abundant ion. It is formed by the loss of the ethoxy group ($\bullet\text{OCH}_2\text{CH}_3$) to form the 2-methylbutanoyl acylium ion (m/z 85), which then loses a neutral carbon monoxide (CO) molecule.[1][2][4] The resulting fragment is the highly stable sec-butyl carbocation, $[\text{CH}_3\text{CH}_2\text{CH}(\text{CH}_3)]^+$.
- m/z 85: This prominent ion is the 2-methylbutanoyl acylium ion, $[\text{CH}_3\text{CH}_2\text{CH}(\text{CH}_3)\text{CO}]^+$. It is formed by α -cleavage, specifically the loss of the ethoxy radical ($\bullet\text{OC}_2\text{H}_5$) from the molecular ion.[3][5]
- m/z 102: This ion results from a McLafferty rearrangement, a characteristic fragmentation for esters with a sufficiently long alkyl chain on the alcohol moiety.[6][7] In this process, a hydrogen from the ethyl group is transferred to the carbonyl oxygen, leading to the elimination of a neutral ethylene molecule (C_2H_4). The resulting ion has the structure of the protonated 2-methylbutyric acid radical cation, $[\text{CH}_3\text{CH}_2\text{CH}(\text{CH}_3)\text{COOH}]^+\bullet$.
- m/z 29: This signal corresponds to the ethyl cation, $[\text{CH}_2\text{CH}_3]^+$, formed by the cleavage of the C-O bond.[4][8]

Q2: I am using Ethyl-d5 2-Methylbutyrate as an internal standard. How does the deuterium labeling affect the molecular ion and the overall spectrum?

Ethyl-d5 2-Methylbutyrate has the deuterium atoms on the ethyl ester group ($-\text{OCD}_2\text{CD}_3$). This substitution increases the mass of the ethyl group from 29 amu to 34 amu.

Consequently, the molecular weight of **Ethyl-d5 2-Methylbutyrate** is 135.21 g/mol. The molecular ion peak ($\text{M}^+\bullet$), if observed, will appear at m/z 135. The labeling is specifically designed to create a predictable mass shift for certain fragments, allowing it to be distinguished from its unlabeled counterpart in a complex matrix.

Q3: Why is the base peak in my spectrum of Ethyl-d5 2-Methylbutyrate still at m/z 57? I expected it to shift.

This is a critical and expected observation that confirms both the identity of the compound and the location of the isotopic label. The base peak at m/z 57 corresponds to the sec-butyl cation, $[\text{CH}_3\text{CH}_2\text{CH}(\text{CH}_3)]^+$.

The formation pathway for this ion involves two steps:

- Loss of the deuterated ethoxy radical ($\bullet\text{OCD}_2\text{CD}_3$) to form the acylium ion at m/z 85.
- Subsequent loss of a neutral CO molecule from this acylium ion.

Since the deuterium labels are entirely contained within the ethoxy group that is lost in the first step, the resulting acylium ion (m/z 85) and the subsequent sec-butyl cation (m/z 57) are unlabeled. Therefore, the base peak correctly remains at m/z 57.

Q4: Which fragment ions are expected to show a mass shift for Ethyl-d5 2-Methylbutyrate, and which should remain unchanged?

The key to interpreting the spectrum is to track which fragments retain the deuterated ethyl group. The expected shifts are summarized in the table below.

Fragment Name	Ion Structure	m/z (Unlabeled)	m/z (Ethyl-d5)	Explanation of Shift
Molecular Ion	$[C_7H_{14}O_2]^+\bullet$	130	135	Full molecule contains the C_2D_5 group (+5 amu).
sec-Butyl Cation (Base Peak)	$[C_4H_9]^+$	57	57	No Shift: The C_2D_5 group is lost prior to formation.
Acylium Ion	$[C_5H_9O]^+$	85	85	No Shift: Formed by loss of the $\bullet OC_2D_5$ radical.
McLafferty Ion	$[C_5H_{10}O_2]^+\bullet$	102	103	Shift of +1 amu: A deuterium atom is transferred to the carbonyl group, and neutral C_2D_4 (32 amu) is lost ($135 - 32 = 103$).
Ethyl Cation	$[C_2H_5]^+$	29	34	Shift of +5 amu: This fragment is the deuterated ethyl group itself.

Visualizing the Fragmentation Pathways

The following diagram illustrates the core fragmentation mechanisms for both Ethyl 2-Methylbutyrate and its d5-labeled analog.

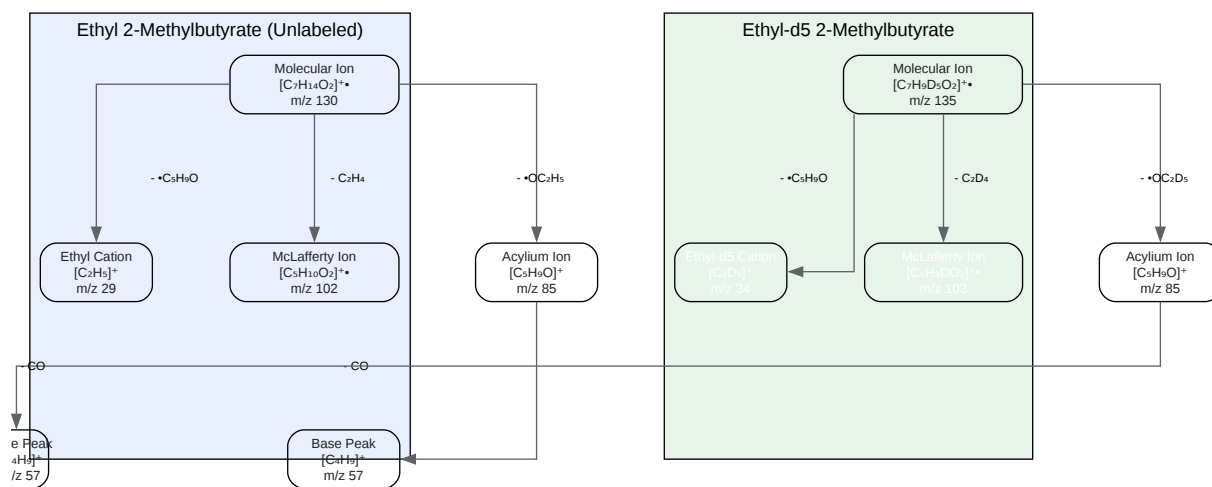

[Click to download full resolution via product page](#)

Caption: Primary EI fragmentation pathways for labeled and unlabeled Ethyl 2-Methylbutyrate.

Troubleshooting Guide: Experimental Protocol

Q5: I am not getting a clean or reproducible spectrum.

What is a recommended method for acquiring high-quality data?

Inconsistent or noisy spectra can result from issues with sample introduction, chromatography, or mass spectrometer parameters. Here is a robust, self-validating protocol for analyzing **Ethyl-d5 2-Methylbutyrate** using Gas Chromatography-Mass Spectrometry (GC-MS).

Objective: To obtain a clean, reproducible electron ionization mass spectrum of **Ethyl-d5 2-Methylbutyrate**.

Materials:

- GC-MS system equipped with an Electron Ionization (EI) source.
- Standard non-polar capillary column (e.g., 30 m x 0.25 mm ID, 0.25 μ m film thickness, 5% phenyl-methylpolysiloxane phase like a DB-5ms or HP-5MS).
- **Ethyl-d5 2-Methylbutyrate** standard solution (e.g., 10-100 μ g/mL in a suitable solvent like methanol or ethyl acetate).
- Helium (carrier gas), 99.999% purity or higher.

Step-by-Step Protocol:

- Sample Preparation:
 - Prepare a dilute solution of your standard to avoid column and detector saturation. A concentration of \sim 50 μ g/mL is a good starting point.
 - Ensure the solvent used is volatile and will not co-elute with your analyte.
- GC Method Parameters:
 - Injection Port:
 - Mode: Split (a split ratio of 50:1 is typical to handle the solvent and prevent peak tailing).
 - Temperature: 250 $^{\circ}$ C.
 - Carrier Gas: Helium at a constant flow rate of 1.0 mL/min.
 - Oven Temperature Program:
 - Initial Temperature: 40 $^{\circ}$ C, hold for 2 minutes.
 - Ramp: Increase temperature at 10 $^{\circ}$ C/min to 280 $^{\circ}$ C.

- Final Hold: Hold at 280 °C for 5 minutes (to clean the column).
- Injection Volume: 1 µL.
- MS Method Parameters:
 - Ionization Mode: Electron Ionization (EI).
 - Ionization Energy: 70 eV. This is the standard energy used to generate reproducible spectra that are comparable to library databases.[9]
 - Source Temperature: 230 °C.
 - Quadrupole Temperature: 150 °C.
 - Transfer Line Temperature: 280 °C.
 - Acquisition Mode: Full Scan.
 - Scan Range: m/z 25 to 200. This range will capture all relevant fragments without collecting unnecessary low-mass background ions.
 - Solvent Delay: Set a solvent delay of 2-3 minutes to prevent the filament from turning on during the solvent peak elution, which preserves its lifespan.
- Data Analysis:
 - Identify the chromatographic peak for **Ethyl-d5 2-Methylbutyrate**.
 - Extract the mass spectrum from the apex of the peak.
 - Perform a background subtraction using a spectrum from the baseline just before or after the peak to obtain a clean spectrum.
 - Compare the resulting fragment ions (m/z 135, 103, 85, 57, 34) to the expected pattern outlined in this guide.

References

- López, R., et al. (2007). Solid phase extraction, multidimensional gas chromatography mass spectrometry determination of four novel aroma powerful ethyl esters. Assessment of their occurrence and importance in wine and other alcoholic beverages. Journal of Chromatography A. [\[Link\]](#)
- Jackson, G. (2010). Gas Chromatography Tandem Mass Spectrometry for Biomarkers of Alcohol Abuse in Human Hair. Therapeutic Drug Monitoring. [\[Link\]](#)
- Yu, X., et al. (2013). Gas chromatography-mass spectrometry analysis of fatty acid ethyl esters in lipid extracts from strains CB0 and CB2. ResearchGate. [\[Link\]](#)
- Martin, G. E., & Figert, D. M. (1974). Quantitative Gas-Liquid Chromatographic Determination of Ethyl Esters and Isoamyl Acetate in Whiskies and Rums and Confirmation by Mass Spectrometry. Journal of AOAC INTERNATIONAL. [\[Link\]](#)
- Berrios, M. (n.d.). Identification of Aromatic Fatty Acid Ethyl Esters. TDX. [\[Link\]](#)
- NIST. (n.d.). Ethyl 2-methylbutanoate-d-9. NIST Chemistry WebBook. [\[Link\]](#)
- Science Ready. (n.d.). Mass Spectrometry Fragmentation Patterns. HSC Chemistry. [\[Link\]](#)
- University of Arizona. (n.d.). Interpretation of mass spectra. CHEM 526 Handout. [\[Link\]](#)
- PubChem. (n.d.). Ethyl 2-methylbutyrate. National Center for Biotechnology Information. [\[Link\]](#)
- University of Michigan. (n.d.). Fragmentation Mechanisms. Intro to Mass Spectrometry. [\[Link\]](#)
- NIST. (n.d.). Butanoic acid, 2-methyl-, ethyl ester. NIST Chemistry WebBook. [\[Link\]](#)
- Harrison, A. G., & Keyes, B. G. (1968). REARRANGEMENT REACTIONS FOLLOWING ELECTRON IMPACT ON ETHYL AND ISOPROPYL ESTERS. Canadian Journal of Chemistry. [\[Link\]](#)
- Clark, J. (2015). Fragmentation patterns in mass spectra. Chemguide. [\[Link\]](#)
- Whitman College. (n.d.). GCMS Section 6.14 - Fragmentation of Esters. GCMS Manual. [\[Link\]](#)

- NIST. (n.d.). (Z)-Ethyl 2-methylbut-2-enoate. NIST Chemistry WebBook. [\[Link\]](#)
- Wikipedia. (2023). Fragmentation (mass spectrometry). Wikipedia. [\[Link\]](#)
- Filo. (2026). The mass spectrum of ethyl butanoate shows two characteristic peaks due to...
Filo - Instant Tutoring. [\[Link\]](#)
- NIST. (n.d.). Butanoic acid, 2-methyl-, ethyl ester. NIST Chemistry WebBook. [\[Link\]](#)
- TutorChase. (n.d.). What are the common fragments in mass spectrometry for esters?
TutorChase. [\[Link\]](#)
- Kumbáľková, T., et al. (2023). Ethyl-2-methylbutyrate (butanoic acid, 2-methyl-, ethyl ester)
synthesis in the monoculture of (A) *C. albicans*, (B) *S. aureus*, and (C) their co-culture.
ResearchGate. [\[Link\]](#)
- Doc Brown's Chemistry. (2025). mass spectrum of 2-methylbutane fragmentation pattern.
Doc Brown's Advanced Organic Chemistry. [\[Link\]](#)
- Vrkoslav, V., et al. (2018). Structural characterization of wax esters by electron ionization
mass spectrometry. Journal of Mass Spectrometry. [\[Link\]](#)
- Chemistry LibreTexts. (2019). Fragmentation Patterns in Mass Spectra. Chemistry
LibreTexts. [\[Link\]](#)
- SIELC Technologies. (2018). Ethyl 2-methylbutyrate. SIELC. [\[Link\]](#)
- FooDB. (2011). Showing Compound (S)-(+)-ethyl-2-methylbutanoate (FDB029639). FooDB.
[\[Link\]](#)

Need Custom Synthesis?

BenchChem offers custom synthesis for rare earth carbides and specific isotopic labeling.

Email: info@benchchem.com or [Request Quote Online](#).

Sources

- [1. Ethyl 2-methylbutyrate | C7H14O2 | CID 24020 - PubChem \[pubchem.ncbi.nlm.nih.gov\]](#)
- [2. Butanoic acid, 2-methyl-, ethyl ester \[webbook.nist.gov\]](#)
- [3. GCMS Section 6.14 \[people.whitman.edu\]](#)
- [4. chemguide.co.uk \[chemguide.co.uk\]](#)
- [5. tutorchase.com \[tutorchase.com\]](#)
- [6. tdx.cat \[tdx.cat\]](#)
- [7. Fragmentation \(mass spectrometry\) - Wikipedia \[en.wikipedia.org\]](#)
- [8. chem.libretexts.org \[chem.libretexts.org\]](#)
- [9. uni-saarland.de \[uni-saarland.de\]](#)
- To cite this document: BenchChem. [Technical Support Center: Fragmentation Analysis of Ethyl-d5 2-Methylbutyrate]. BenchChem, [2026]. [Online PDF]. Available at: [\[https://www.benchchem.com/product/b592414/docs#technical-support-center-fragmentation-analysis-of-ethyl-d5-2-methylbutyrate\]](https://www.benchchem.com/product/b592414/docs#technical-support-center-fragmentation-analysis-of-ethyl-d5-2-methylbutyrate)

Disclaimer & Data Validity:

The information provided in this document is for Research Use Only (RUO) and is strictly not intended for diagnostic or therapeutic procedures. While BenchChem strives to provide accurate protocols, we make no warranties, express or implied, regarding the fitness of this product for every specific experimental setup.

Technical Support: The protocols provided are for reference purposes. Unsure if this reagent suits your experiment?

Need Industrial/Bulk Grade? [Request Custom Synthesis Quote](#)

BenchChem

Our mission is to be the trusted global source of essential and advanced chemicals, empowering scientists and researchers to drive progress in science and industry.

Contact

Address: 3281 E Guasti Rd

Ontario, CA 91761, United States

Phone: (601) 213-4426

Email: info@benchchem.com

Contact our Ph.D. Support Team for a compatibility check