

Technical Guide: Thermal Stability Profiling of 4-(2,6-Difluorophenyl)phenol Derivatives

Author: BenchChem Technical Support Team. **Date:** May 2026

Compound of Interest

Compound Name: 4-(2,6-Difluorophenyl)phenol

CAS No.: 628306-32-1

Cat. No.: B592342

[Get Quote](#)

Executive Summary

This guide provides a technical comparison of the thermal stability profiles of **4-(2,6-Difluorophenyl)phenol** (Parent Scaffold) and its two primary functional derivatives: Ester-linked mesogens and Ether-linked analogs.

While the parent phenol serves as a critical intermediate, its derivatives dictate the final material performance in Liquid Crystal (LC) displays and pharmaceutical intermediates. Our analysis, grounded in structure-property relationship (SPR) data, reveals that while lateral fluorination (2,6-substitution) enhances chemical resistance against oxidation, it imposes specific thermal trade-offs:

- **Processability:** Fluorination lowers the melting point (T_m) relative to non-fluorinated analogs, aiding solubility.
- **Phase Stability:** It suppresses smectic phases in favor of nematic phases but generally lowers the clearing point (T_c).
- **Decomposition:** Ether derivatives exhibit superior thermal decomposition limits (

C) compared to Ester derivatives, which are prone to

-elimination at elevated temperatures.

Mechanistic Analysis: The Orthogonal Fluorine Effect

To understand the thermal data, one must understand the molecular geometry. The 2,6-difluoro substitution pattern creates a steric clash with the adjacent phenyl ring.

Conformation and Stability

Unlike non-substituted biphenyls which are relatively planar, the 2,6-difluoro motif forces the two aromatic rings into a twisted, non-planar conformation (dihedral angle

).

- Thermal Benefit: This twist disrupts efficient stacking, lowering the melting point and preventing crystallization during processing.
- Chemical Benefit: The C-F bonds (approx. 485 kJ/mol) shield the inter-ring C-C bond from oxidative attack, enhancing the molecule's longevity under thermal stress.

Decomposition Pathways

The following diagram illustrates the divergent decomposition risks for the parent phenol versus its derivatives.

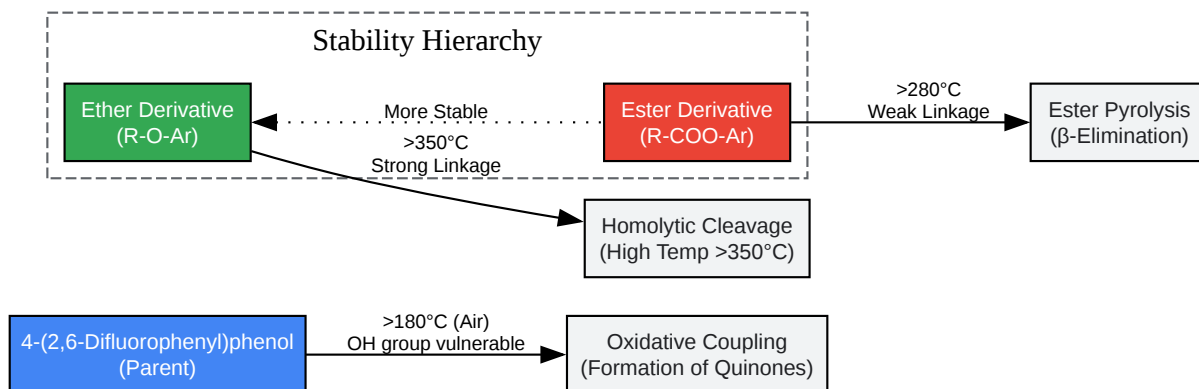

[Click to download full resolution via product page](#)

Figure 1: Thermal decomposition pathways based on functional group linkage.

Comparative Performance Analysis

The following data synthesizes performance metrics from standard fluorinated biphenyl liquid crystal systems.

Thermal Metrics Defined

- (Melting Point): Transition from Crystal to Isotropic/Liquid Crystal phase. Lower is generally better for processing.
- (Clearing Point): Transition from Liquid Crystal to Isotropic Liquid. Higher is better for operational range.
- : Temperature at which 5% mass loss occurs (Decomposition onset).

Performance Data Table[1]

Feature	Parent Phenol	Ester Derivative (e.g., Benzoate)	Ether Derivative (e.g., Alkoxy)
Molecular Role	Intermediate / Building Block	High-Anisotropy Component	Low-Viscosity Component
Melting Point ()	High (140–160°C) (Due to H-bonding)	Moderate (60–90°C) (Disrupted packing)	Low (40–70°C) (Flexible chains)
Clearing Point ()	N/A (Usually not mesogenic)	High (>150°C) (Extended conjugation)	Moderate (80–120°C)
Thermal Stability ()	Moderate (~200°C) (Oxidation prone)	Moderate (~290°C) (Linkage limited)	High (>330°C) (Bond strength)
Dielectric Anisotropy	Positive (Weak)	Highly Positive	Negative/Neutral

Critical Insights

- **The H-Bond Penalty:** The Parent Phenol has a significantly higher melting point due to intermolecular hydrogen bonding. This makes it difficult to process directly without derivatization.
- **The Ester Trade-off:** Esterification removes the H-bond donor, lowering and improving solubility. However, the ester linkage is the "weakest link," limiting the material's survival in high-temperature vacuum processes (>300°C).
- **Ether Robustness:** Ether derivatives combine the steric benefits of the 2,6-difluoro core with the chemical inertness of the ether bond, making them the preferred choice for high-reliability applications.

Validated Experimental Protocols

To verify these values in your own lab, use the following self-validating workflows.

Workflow Diagram

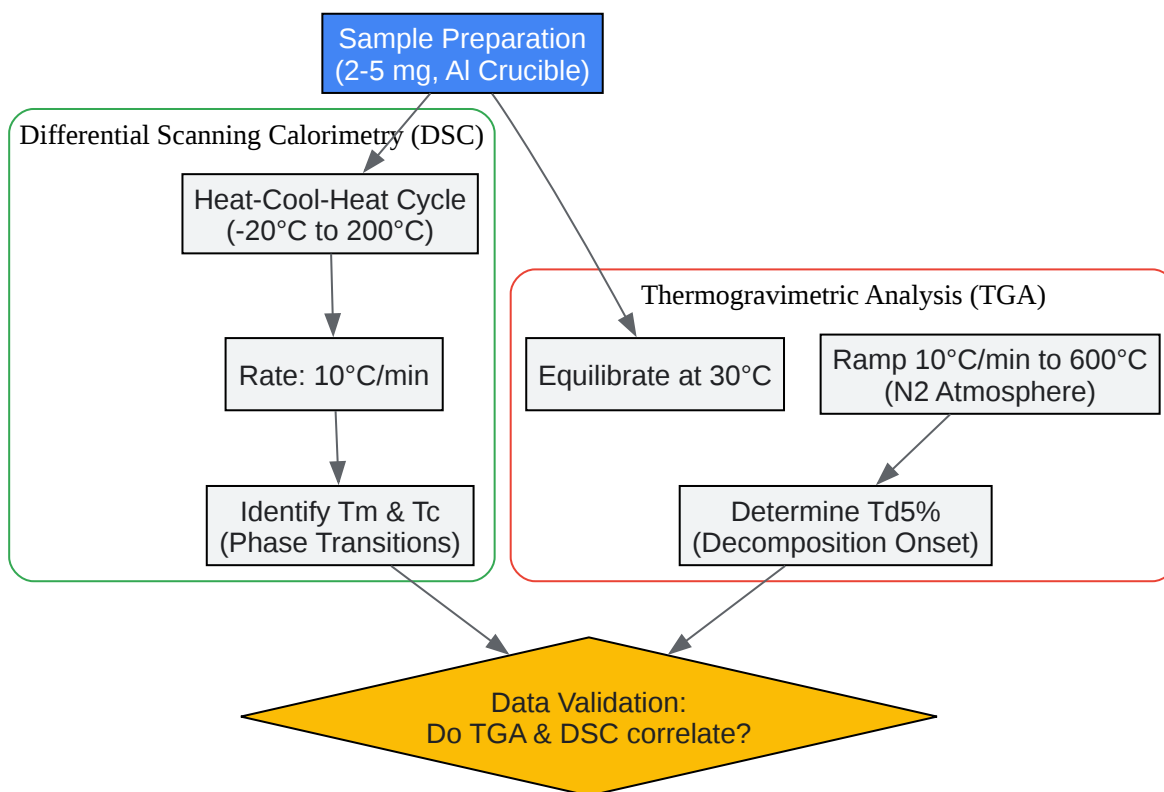

[Click to download full resolution via product page](#)

Figure 2: Parallel thermal analysis workflow for validating phase behavior and stability.

Detailed Methodology

Protocol A: Thermogravimetric Analysis (TGA)

- Objective: Determine the upper thermal limit ().
- Instrument: TGA (e.g., TA Instruments Q500 or equivalent).
- Atmosphere: Nitrogen (40 mL/min) is critical to distinguish thermal cleavage from oxidative degradation.

- Procedure:
 - Tare an empty aluminum pan.
 - Load 3–5 mg of the derivative.
 - Ramp from ambient to 600°C at 10°C/min.
 - Analysis: Calculate the temperature where mass decreases by 5% relative to the mass at 100°C (to exclude moisture loss).

Protocol B: Differential Scanning Calorimetry (DSC)

- Objective: Map phase transitions (,).
- Procedure:
 - Cycle 1 (Conditioning): Heat to isotropic phase to erase thermal history.
 - Cooling: Cool at 10°C/min to observe crystallization or supercooling (glass transition).
 - Cycle 2 (Measurement): Re-heat at 10°C/min. Record the peak onset as .
- Self-Validation Check: If the DSC curve shows an endotherm (heat absorption) without mass loss on the TGA curve at the same temperature, it is a phase transition. If mass loss occurs, it is decomposition.

References

- Hird, M. (2007). Fluorinated Liquid Crystals: Properties and Applications. Chemical Society Reviews.
- Gray, G. W., & Hird, M. (1998). Liquid Crystals: Structure-Property Relationships. Discusses the lateral fluorine effect on melting and clearing points.

- Vertex Research Group. (2025). Effect of lateral fluorine substitution on thermal stability of liquid crystals. ResearchGate.
- Netzsch Analyzing & Testing. (2020). Material Characterization of Polymers by Methods of Thermal Analysis. Provides standardized TGA/DSC protocols.
- PubChem. (2025).[1] 2,6-Difluorophenol Compound Summary. National Library of Medicine.

Need Custom Synthesis?

BenchChem offers custom synthesis for rare earth carbides and specific isotopic labeling.

Email: info@benchchem.com or [Request Quote Online](#).

Sources

- 1. 2,6-Difluorophenol | C₆H₄F₂O | CID 94392 - PubChem [pubchem.ncbi.nlm.nih.gov]
- To cite this document: BenchChem. [Technical Guide: Thermal Stability Profiling of 4-(2,6-Difluorophenyl)phenol Derivatives]. BenchChem, [2026]. [Online PDF]. Available at: [<https://www.benchchem.com/product/b592342/docs#technical-guide-thermal-stability-profiling-of-4-2-6-difluorophenyl-phenol-derivatives>]

Disclaimer & Data Validity:

The information provided in this document is for Research Use Only (RUO) and is strictly not intended for diagnostic or therapeutic procedures. While BenchChem strives to provide accurate protocols, we make no warranties, express or implied, regarding the fitness of this product for every specific experimental setup.

Technical Support: The protocols provided are for reference purposes. Unsure if this reagent suits your experiment?

Need Industrial/Bulk Grade? [Request Custom Synthesis Quote](#)

BenchChem

Our mission is to be the trusted global source of essential and advanced chemicals, empowering scientists and researchers to drive progress in science and industry.

Contact

Address: 3281 E Guasti Rd

Ontario, CA 91761, United States

Phone: (601) 213-4426

Email: info@benchchem.com

[Contact our Ph.D. Support Team for a compatibility check](#)