

Application Notes and Protocols for the Quantification of Rengynic Acid

Author: BenchChem Technical Support Team. **Date:** April 2026

Compound of Interest

Compound Name: *Rengynic acid*

CAS No.: 1310146-00-9

Cat. No.: B592748

[Get Quote](#)

Disclaimer: As of the current date, specific, validated analytical methods for a compound explicitly named "**Rengynic acid**" are not readily available in the public scientific literature. The following application notes and protocols have been developed by adapting established methods for the analysis of structurally similar organic acids. These should serve as a comprehensive starting point for method development and validation by researchers, scientists, and drug development professionals.

Introduction

Rengynic acid is a compound with potential antiviral properties, isolated from *Forsythia suspensa*[1]. Accurate and reliable quantification of **Rengynic acid** is essential for various stages of research and development, including pharmacokinetic studies, quality control of herbal preparations, and formulation development. This document provides detailed protocols for the quantification of **Rengynic acid** using High-Performance Liquid Chromatography (HPLC) with UV detection and Liquid Chromatography-Tandem Mass Spectrometry (LC-MS/MS).

The provided methodologies are based on analytical strategies for other organic acids and polyphenolic compounds, offering robust starting points for optimization based on specific matrix requirements.

High-Performance Liquid Chromatography (HPLC) Method

This section details a reversed-phase HPLC method for the quantification of **Rengynic acid**.

Experimental Protocol

1. Instrumentation and Materials

- HPLC System: Equipped with a binary or quaternary pump, autosampler, column oven, and a UV-Vis or Diode Array Detector (DAD).
- Analytical Column: A C18 reversed-phase column (e.g., 250 mm x 4.6 mm, 5 µm particle size) is recommended for good resolution[2].
- Reagents and Solvents:
 - **Rengynic acid** reference standard (purity ≥98%)
 - Acetonitrile (HPLC grade)
 - Methanol (HPLC grade)
 - Water (HPLC grade or ultrapure)
 - Phosphoric acid or Formic acid (for mobile phase modification)
- Filters: 0.45 µm Syringe filters (e.g., PVDF or PTFE).

2. Chromatographic Conditions

- Mobile Phase: A typical starting condition is an isocratic mixture of Acetonitrile and 0.1% Phosphoric acid in water (e.g., 60:40 v/v)[2]. The mobile phase should be filtered and

degassed prior to use. Gradient elution may be necessary to resolve **Rengynic acid** from matrix components.

- Flow Rate: 1.0 mL/min[2][3].
- Column Temperature: 30 °C[2].
- Detection Wavelength: A starting wavelength of 215 nm is suggested due to the potential presence of conjugated double bonds[2]. A UV scan of the **Rengynic acid** standard is recommended to determine the optimal wavelength.
- Injection Volume: 10 µL[3].
- Run Time: Approximately 10-15 minutes, sufficient to elute the analyte and any interfering peaks[2].

3. Standard and Sample Preparation

- Stock Solution (1 mg/mL): Accurately weigh 10 mg of **Rengynic acid** standard and dissolve it in 10 mL of methanol in a volumetric flask[2].
- Working Standards: Prepare a series of working standards by diluting the stock solution with the mobile phase to achieve concentrations ranging from approximately 1 µg/mL to 100 µg/mL for constructing a calibration curve[2].
- Sample Preparation (General Guidelines):
 - Liquid Samples (e.g., formulations): Dilute the sample with methanol to bring the expected **Rengynic acid** concentration within the calibration range[2].
 - Solid Samples (e.g., plant material): Homogenize a known amount of the solid sample. Perform a solvent extraction using methanol or acetonitrile, potentially using sonication to enhance extraction efficiency. Centrifuge the extract, collect the supernatant, and if necessary, evaporate the solvent and reconstitute in the mobile phase[2].
 - Biological Samples (e.g., plasma): Protein precipitation is a common method. Add a cold organic solvent like methanol or acetonitrile (typically 3 volumes of solvent to 1 volume of

plasma), vortex, and centrifuge to pellet the proteins. The supernatant can then be injected or further processed[4].

- Final Step: All samples and standards must be filtered through a 0.45 µm syringe filter before injection[2].

Data Presentation: HPLC Method Performance (Exemplary)

The following table summarizes typical performance characteristics for HPLC methods used for the quantification of organic acids. These values should be established during method validation for **Rengynic acid**.

Parameter	Typical Performance Characteristics
Linearity Range	0.25 - 20 µg/mL
Correlation Coefficient (r ²)	≥ 0.998
Precision (RSD%)	Intra-day: < 8.5%, Inter-day: < 7.1%[5]
Accuracy (RE%)	Within ±15% (±20% at LLOQ)
Recovery (%)	> 80%
Limit of Detection (LOD)	Dependent on UV absorbance, typically in the low ng/mL range.
Limit of Quantification (LOQ)	0.20 - 0.25 µg/mL[5]

HPLC Experimental Workflow

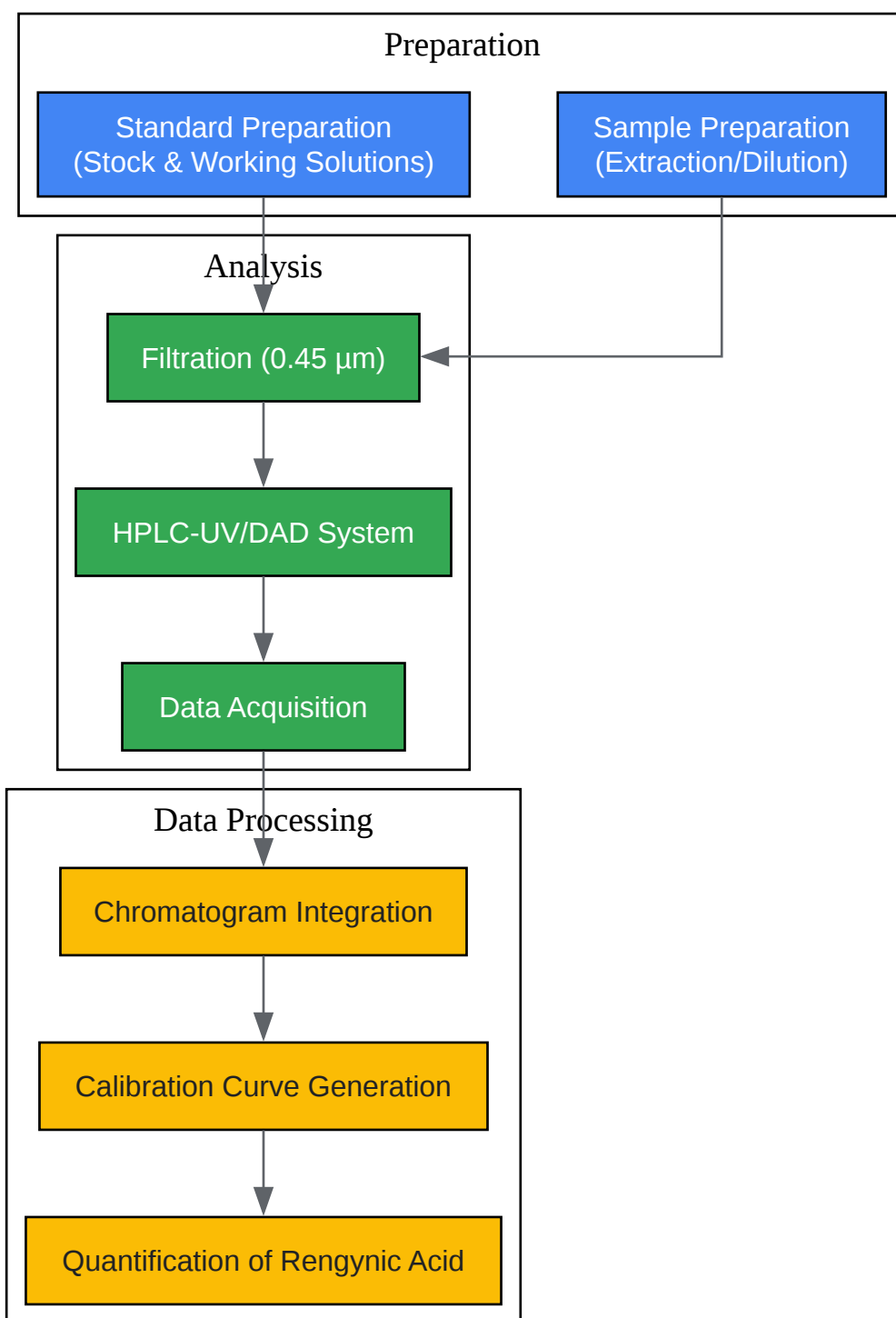

[Click to download full resolution via product page](#)

Caption: Workflow for **Rengynic acid** quantification by HPLC.

Liquid Chromatography-Tandem Mass Spectrometry (LC-MS) Method

For higher sensitivity and selectivity, especially in complex matrices like biological fluids, an LC-MS/MS method is recommended.

Experimental Protocol

1. Instrumentation and Materials

- **LC-MS/MS System:** A liquid chromatography system coupled to a triple quadrupole mass spectrometer.
- **Analytical Column:** A C18 column with a smaller particle size (e.g., 50 mm x 2.1 mm, 1.8 μm) is suitable for faster analysis[4].
- **Reagents and Solvents:** As per the HPLC method, with the addition of formic acid for mobile phase acidification, which is compatible with mass spectrometry.
- **Internal Standard (IS):** A structurally similar compound, if available, or a stable isotope-labeled version of **Rengynic acid** should be used for accurate quantification[4].

2. Chromatographic Conditions

- **Mobile Phase:** A gradient elution using water with 0.1% formic acid (Solvent A) and acetonitrile or methanol with 0.1% formic acid (Solvent B) is common[4]. A typical gradient might start with a low percentage of Solvent B, increasing to elute the analyte, followed by a wash and re-equilibration step.
- **Flow Rate:** 0.4 mL/min[4].
- **Column Temperature:** 40 °C.
- **Injection Volume:** 5 μL .

3. Mass Spectrometer Conditions

- Ionization Mode: Electrospray Ionization (ESI) in negative mode is typically used for acidic compounds[4].
- Source Parameters: These need to be optimized for **Rengynic acid** but can be initiated based on typical values:
 - Spray Voltage: -4500 V
 - Source Temperature: 550 °C
 - Curtain Gas, Nebulizer Gas (GS1), Heater Gas (GS2): Optimized based on instrument manufacturer's recommendations.
- Analyte-Specific Parameters (MRM): These must be determined by infusing a standard solution of **Rengynic acid**.
 - Precursor Ion ($[M-H]^-$): The deprotonated molecular ion of **Rengynic acid**.
 - Product Ions: Characteristic fragment ions generated by collision-induced dissociation of the precursor ion. At least two transitions (one for quantification, one for confirmation) are recommended.
 - Collision Energy (CE) and Declustering Potential (DP): Optimized for each transition to maximize signal intensity.

4. Standard and Sample Preparation

- Follow the same principles as for the HPLC method, but include the addition of the internal standard at a fixed concentration to all samples and standards.

Data Presentation: LC-MS/MS Method Performance (Exemplary)

The following table summarizes typical performance characteristics for LC-MS/MS methods for the quantification of organic acids in biological matrices.

Parameter	Typical Performance Characteristics
Linearity Range	10 - 2000 ng/mL[4]
Correlation Coefficient (r ²)	≥ 0.995
Precision (RSD%)	Intra- and Inter-day: < 10.7%[4]
Accuracy (RE%)	-3.0% to 10.6%[4]
Recovery (%)	Consistent and reproducible across the concentration range.
Limit of Detection (LOD)	Typically in the low pg/mL to low ng/mL range.
Limit of Quantification (LOQ)	5.0 - 10 ng/mL[6][7]

LC-MS/MS Experimental Workflow

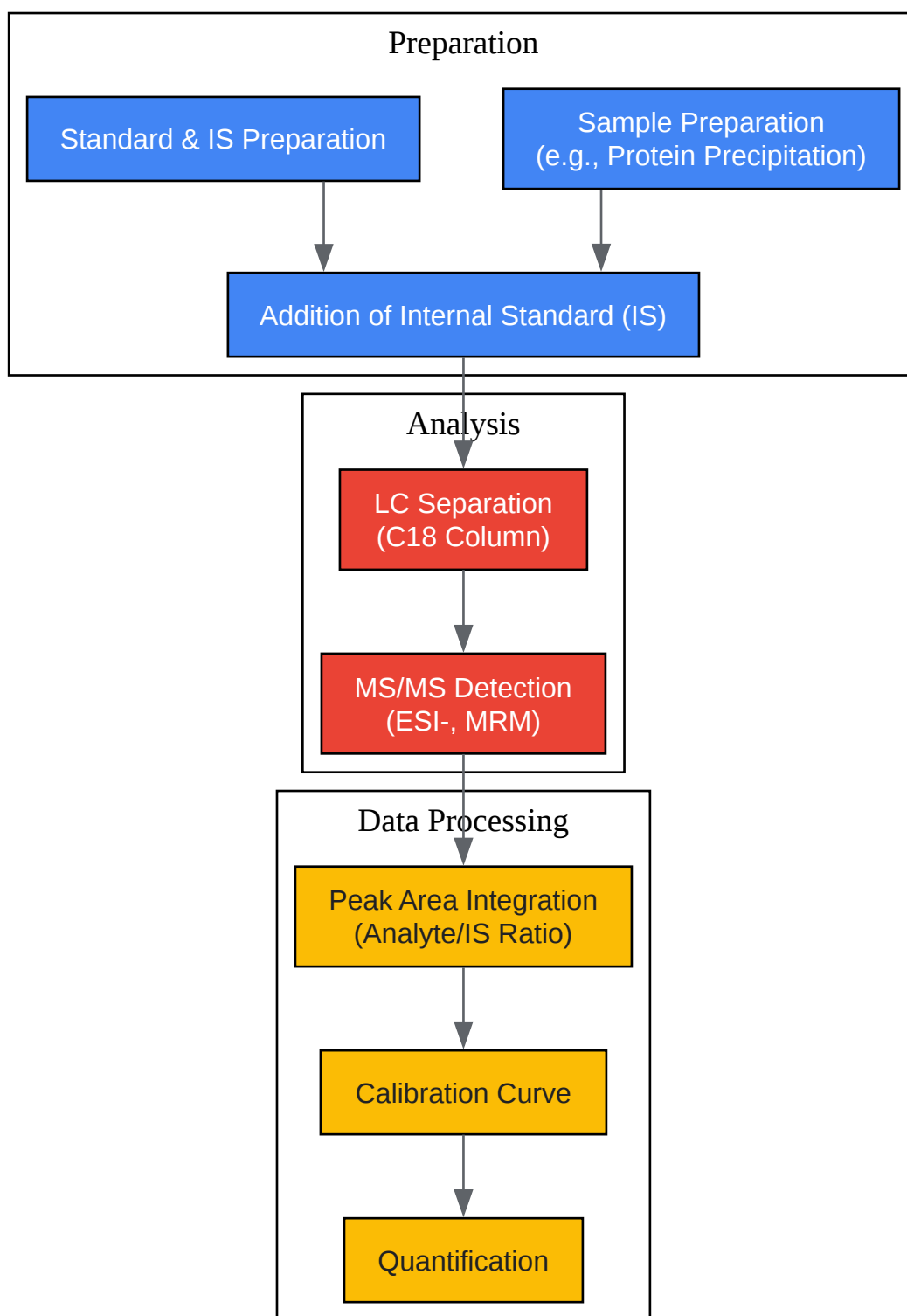

[Click to download full resolution via product page](#)

Caption: Workflow for **Rengynic acid** quantification by LC-MS/MS.

Need Custom Synthesis?

BenchChem offers custom synthesis for rare earth carbides and specific isotopic labeling.

Email: info@benchchem.com or [Request Quote Online](#).

References

- [1. medchemexpress.com](https://www.medchemexpress.com) [[medchemexpress.com](https://www.medchemexpress.com)]
- [2. benchchem.com](https://www.benchchem.com) [[benchchem.com](https://www.benchchem.com)]
- [3. ijpsonline.com](https://www.ijpsonline.com) [[ijpsonline.com](https://www.ijpsonline.com)]
- 4. Development of an LC-MS/MS method for quantitative analysis of Chlorogenic acid in human plasma and its application to a pharmacokinetic study in Chinese patients with advanced solid tumor - PubMed [pubmed.ncbi.nlm.nih.gov]
- 5. Determination and pharmacokinetic study of syringin and chlorogenic acid in rat plasma after administration of Aidi lyophilizer - PubMed [pubmed.ncbi.nlm.nih.gov]
- 6. Development and validation of an LC-MS/MS method to quantify kynurenic acid in human plasma - PubMed [pubmed.ncbi.nlm.nih.gov]
- 7. Method Development and Validation for Pharmacokinetic and Tissue Distributions of Ellagic Acid Using Ultrahigh Performance Liquid Chromatography-Tandem Mass Spectrometry (UPLC-MS/MS) [[mdpi.com](https://www.mdpi.com)]
- To cite this document: BenchChem. [Application Notes and Protocols for the Quantification of Rengynic Acid]. BenchChem, [2026]. [Online PDF]. Available at: [<https://www.benchchem.com/product/b592748/docs#application-notes-and-protocols-for-the-quantification-of-rengynic-acid>]

Disclaimer & Data Validity:

The information provided in this document is for Research Use Only (RUO) and is strictly not intended for diagnostic or therapeutic procedures. While BenchChem strives to provide accurate protocols, we make no warranties, express or implied, regarding the fitness of this product for every specific experimental setup.

Technical Support: The protocols provided are for reference purposes. Unsure if this reagent suits your experiment?

Need Industrial/Bulk Grade? [Request Custom Synthesis Quote](#)

BenchChem

Our mission is to be the trusted global source of essential and advanced chemicals, empowering scientists and researchers to drive progress in science and industry.

Contact

Address: 3281 E Guasti Rd
Ontario, CA 91761, United States
Phone: (601) 213-4426
Email: info@benchchem.com

[Contact our Ph.D. Support Team for a compatibility check](#)