

spectroscopic data for D3-METHYL BENZOYLFORMATE

Author: BenchChem Technical Support Team. **Date:** May 2026

Compound of Interest

Compound Name: D3-METHYL BENZOYLFORMATE

CAS No.: 134839-87-5

Cat. No.: B591370

[Get Quote](#)

An In-Depth Technical Guide to the Spectroscopic Analysis of **D3-Methyl Benzoylformate**

Introduction

In the realms of pharmaceutical development, metabolic research, and quantitative analysis, isotopically labeled compounds are indispensable tools. **D3-Methyl Benzoylformate**, a deuterated analogue of methyl benzoylformate, serves as a critical internal standard in bioanalytical assays and as a probe in mechanistic studies. Its utility is predicated on its chemical identity and isotopic purity, which can be unequivocally verified through a suite of spectroscopic techniques. The incorporation of deuterium atoms imparts a unique spectroscopic signature, readily distinguishable from its non-labeled counterpart.

This guide provides a comprehensive exploration of the core spectroscopic data for **D3-Methyl Benzoylformate**, intended for researchers, scientists, and drug development professionals. We will delve into the theoretical underpinnings and practical application of Infrared (IR) Spectroscopy, Nuclear Magnetic Resonance (NMR) Spectroscopy, and Mass Spectrometry (MS). The narrative emphasizes the causality behind experimental choices and the

interpretation of spectral data, ensuring a self-validating approach to compound identification and characterization.

Part 1: Molecular Structure and Isotopic Labeling

D3-Methyl Benzoylformate shares the same molecular framework as methyl benzoylformate, with the crucial exception of the three hydrogen atoms on the methyl group being replaced by deuterium atoms. This seemingly subtle change has profound implications for its spectroscopic properties.

Caption: Molecular Structure of **D3-Methyl Benzoylformate**.

Part 2: Infrared (IR) Spectroscopy

Theoretical Basis

Infrared spectroscopy probes the vibrational modes of a molecule. The absorption of infrared radiation at specific frequencies corresponds to the energy required to excite a particular bond vibration (e.g., stretching, bending). While the overall IR spectrum is dominated by the stronger absorptions of the carbonyl groups and the aromatic ring, the isotopic labeling in the methyl group introduces subtle but detectable changes. The C-D bond is stronger and involves a heavier atom than the C-H bond, resulting in C-D stretching and bending vibrations occurring at lower frequencies (wavenumbers) compared to their C-H counterparts.

Experimental Protocol: Attenuated Total Reflectance (ATR)-IR Spectroscopy

ATR is a common technique for obtaining IR spectra of liquid samples due to its minimal sample preparation requirements.

- **Instrument Preparation:** Ensure the ATR crystal (typically diamond or germanium) is clean. Record a background spectrum of the empty ATR stage.
- **Sample Application:** Place a single drop of **D3-Methyl Benzoylformate** directly onto the center of the ATR crystal.
- **Spectrum Acquisition:** Lower the ATR anvil to ensure good contact between the sample and the crystal. Initiate the scan. Typically, 16 to 32 scans are co-added to improve the signal-to-

noise ratio.

- Data Processing: The resulting spectrum is automatically ratioed against the background spectrum to produce the final absorbance or transmittance spectrum.

Data Interpretation

The IR spectrum of **D3-Methyl Benzoylformate** is expected to be very similar to that of its non-deuterated analogue, with the most significant peaks arising from the carbonyl groups and the phenyl ring.

Functional Group	Vibrational Mode	Expected Wavenumber (cm ⁻¹)	Intensity
C=O (Ketone)	Stretch	~1730-1715	Strong
C=O (Ester)	Stretch	~1750-1735	Strong
C=C (Aromatic)	Stretch	~1600-1450	Medium-Weak
C-O (Ester)	Stretch	~1300-1000	Strong
C-H (Aromatic)	Stretch	~3100-3000	Medium-Weak
C-D (Methyl)	Stretch	~2200-2100	Weak

Note: The C-D stretching frequency is significantly lower than the typical C-H stretching frequency (~3000-2850 cm⁻¹). This region of the spectrum can be used to confirm the presence of the deuterium label, although the peak may be weak.

Part 3: Nuclear Magnetic Resonance (NMR) Spectroscopy

Theoretical Basis

NMR spectroscopy is the most powerful tool for elucidating the structure of organic molecules in solution. It relies on the magnetic properties of atomic nuclei. For this analysis, ¹H, ¹³C, and ²H NMR are all relevant. The use of deuterated solvents is standard practice to avoid large solvent signals in ¹H NMR spectra.^[1]

^1H NMR Spectroscopy

Causality of Deuterium Labeling: In ^1H NMR, signals arise from hydrogen-1 (protium) nuclei. Since deuterium (^2H) has a different gyromagnetic ratio, it is not observed in a standard ^1H NMR experiment. Consequently, the most dramatic and informative feature in the ^1H NMR spectrum of **D3-Methyl Benzoylformate** is the complete absence of the methyl signal.

Experimental Protocol:

- Sample Preparation: Dissolve approximately 5-10 mg of **D3-Methyl Benzoylformate** in ~0.6 mL of a deuterated solvent (e.g., Chloroform-d, CDCl_3) in a 5 mm NMR tube.[2][3][4]
- Instrument Setup: Place the NMR tube in the spectrometer. The instrument is "locked" onto the deuterium signal of the solvent to stabilize the magnetic field. Shimming is performed to optimize the homogeneity of the magnetic field.
- Data Acquisition: A standard ^1H NMR pulse sequence is executed. The Free Induction Decay (FID) is recorded and then Fourier transformed to yield the frequency-domain spectrum.

Data Interpretation:

The ^1H NMR spectrum will exclusively show signals corresponding to the protons on the aromatic ring.

Proton Position	Chemical Shift (δ , ppm)	Multiplicity	Integration
Ortho (2,6)	~7.8-8.0	Multiplet (m)	2H
Meta (3,5)	~7.4-7.6	Multiplet (m)	2H
Para (4)	~7.6-7.8	Multiplet (m)	1H

The absence of a singlet peak around 3.9 ppm, which would be present for the non-deuterated methyl benzoylformate, is conclusive evidence of successful D3-labeling.[5]

^{13}C NMR Spectroscopy

Causality of Deuterium Labeling: In ^{13}C NMR, all carbon atoms are observed. The carbon atom attached to the three deuterium atoms (the CD_3 group) will exhibit two key features:

- **Coupling:** The spin-1 deuterium nucleus couples to the ^{13}C nucleus, splitting the carbon signal into a multiplet (typically a triplet of triplets, often appearing as a septet, due to ^1JCD coupling).
- **Isotope Shift:** The CD_3 carbon will be shifted slightly upfield (to a lower ppm value) compared to a CH_3 carbon in the same environment.

Experimental Protocol:

- **Sample Preparation:** A more concentrated sample (20-50 mg in ~0.6 mL of deuterated solvent) is typically required for ^{13}C NMR compared to ^1H NMR.[4]
- **Data Acquisition:** A standard proton-decoupled ^{13}C NMR experiment is performed. This removes the coupling between carbon and proton atoms, simplifying the spectrum. However, the coupling between carbon and deuterium will remain.

Data Interpretation:

Carbon Position	Expected Chemical Shift (δ , ppm)
C=O (Ketone)	~185-195
C=O (Ester)	~160-170
C (Aromatic, substituted)	~130-135
C-H (Aromatic)	~128-135
CD_3	~52 (as a multiplet)

^2H (Deuterium) NMR Spectroscopy

While less common for routine characterization, ^2H NMR can be used to directly observe the deuterium nuclei.[6] This experiment would show a single resonance in the approximate chemical shift region of the corresponding protons (~3.9 ppm), confirming the presence and chemical environment of the isotopic label.[7]

Part 4: Mass Spectrometry (MS)

Theoretical Basis

Mass spectrometry measures the mass-to-charge ratio (m/z) of ions. For **D3-Methyl Benzoylformate**, the most immediate piece of information is the molecular weight, which will be 3 mass units higher than its non-deuterated counterpart due to the three deuterium atoms. Electron Ionization (EI) is a common technique that also causes fragmentation of the molecule, providing a "fingerprint" that can be used for structural elucidation.[8]

Experimental Protocol: Gas Chromatography-Mass Spectrometry (GC-MS)

GC-MS is an ideal technique for volatile compounds like **D3-Methyl Benzoylformate**, as it separates the analyte from any potential impurities before it enters the mass spectrometer.[9]
[10]

- **Sample Preparation:** Prepare a dilute solution of the sample (~1 mg/mL) in a volatile organic solvent (e.g., dichloromethane or ethyl acetate).
- **GC Separation:** Inject a small volume (e.g., 1 μ L) of the solution into the GC. The sample is vaporized and travels through a capillary column, separating it from other components.
- **Ionization:** As the compound elutes from the GC column, it enters the ion source of the mass spectrometer and is bombarded with high-energy electrons (typically 70 eV), causing ionization and fragmentation.
- **Mass Analysis:** The resulting ions are separated by the mass analyzer (e.g., a quadrupole) based on their m/z ratio, and a mass spectrum is generated.

Data Interpretation and Fragmentation Analysis

The molecular weight of methyl benzoylformate ($C_9H_8O_3$) is 164.16 g/mol .[11][12][13] For **D3-Methyl Benzoylformate** ($C_9H_5D_3O_3$), the expected molecular weight is approximately 167.18 g/mol . The mass spectrum will show a molecular ion peak (M^+) at $m/z = 167$.

The fragmentation pattern provides further structural confirmation. Key fragmentation pathways involve the loss of neutral fragments from the molecular ion.

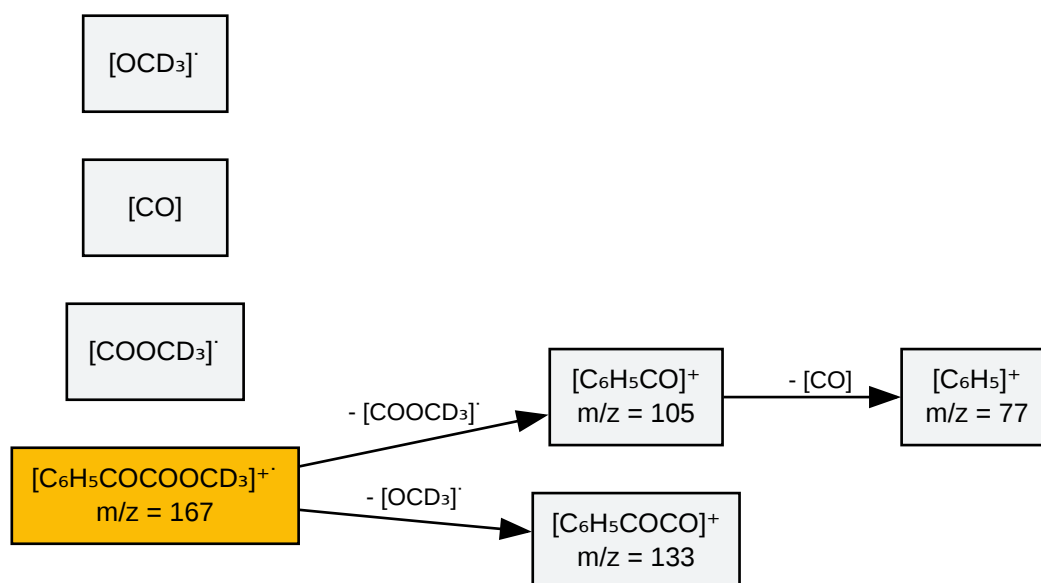

[Click to download full resolution via product page](#)

Caption: Key fragmentation pathways of **D3-Methyl Benzoylformate** in EI-MS.

Table of Expected Fragments:

m/z	Proposed Fragment Ion	Comments
167	$[\text{C}_6\text{H}_5\text{COCOCD}_3]^+$	Molecular Ion (M^+)
136	$[\text{M} - \text{OCD}_3]^+$	Loss of the deuterated methoxy radical
105	$[\text{C}_6\text{H}_5\text{CO}]^+$	Benzoyl cation; a very common and stable fragment
77	$[\text{C}_6\text{H}_5]^+$	Phenyl cation; from loss of CO from the benzoyl cation
51	$[\text{C}_4\text{H}_3]^+$	Common fragment from the phenyl ring

The observation of fragments containing the CD_3 group (or fragments resulting from its loss) provides definitive evidence for the location of the isotopic label.

Conclusion

The spectroscopic analysis of **D3-Methyl Benzoylformate** provides a clear and self-validating picture of its chemical identity and isotopic enrichment. IR spectroscopy confirms the presence of the key functional groups. ^1H NMR spectroscopy provides the most direct evidence of successful deuteration through the absence of the methyl proton signal. ^{13}C NMR complements this by showing the characteristic multiplet of the CD_3 carbon. Finally, mass spectrometry confirms the correct molecular weight and provides a fragmentation pattern consistent with the deuterated structure. Together, these techniques offer a robust analytical workflow for the comprehensive characterization of this important isotopically labeled compound.

References

- Anshul Specialty Molecules. Methyl Benzoylformate. [\[Link\]](#)
- NP-MRD. ^1H NMR Spectrum (1D, 900 MHz, H_2O , predicted) (NP0239650). [\[Link\]](#)
- ChemBK. (2024, April 9). Methyl benzoyl formate. [\[Link\]](#)
- Doc Brown's Advanced Organic Chemistry. infrared spectrum of methyl 2-hydroxybenzoate. [\[Link\]](#)
- National Institute of Standards and Technology. Methyl formate - NIST WebBook. [\[Link\]](#)
- PubChem. Methyl phenylglyoxalate | $\text{C}_9\text{H}_8\text{O}_3$ | CID 84835. [\[Link\]](#)
- ACS Publications. (2005). Mass spectral analysis of isotopically labeled compounds: average mass approach. Analytical Chemistry. [\[Link\]](#)
- Organomation. NMR Sample Preparation: The Complete Guide. [\[Link\]](#)
- ResearchGate. GC/MS analysis of long-chain esters standards. [\[Link\]](#)
- PubMed. Spectrally accurate quantitative analysis of isotope-labeled compounds. [\[Link\]](#)
- Wikipedia. Deuterium NMR. [\[Link\]](#)

- LCGC International. (2023, December 5). Measuring Fatty Acids and Fatty Acid Methyl Esters Using GC–MS/MS. [[Link](#)]
- The Basics of NMR by J.P. Hornak. Sample Preparation. [[Link](#)]
- Chemistry LibreTexts. (2014, August 21). The Use of Deuterium in ^1H NMR Spectroscopy. [[Link](#)]
- Wikipedia. Isotopic labeling. [[Link](#)]
- ACS Publications. (1999). GC/MS of Unknown Esters for Teaching MS Fragmentation Patterns. Journal of Chemical Education. [[Link](#)]
- Agilent. (2005, August 30). Column Selection for the Analysis of Fatty Acid Methyl Esters. [[Link](#)]
- Western University. NMR Sample Preparation. [[Link](#)]
- Chromatography Forum. (2011, August 1). Quantification of Esters by GC-MS. [[Link](#)]
- Iowa State University Chemical Instrumentation Facility. NMR Sample Preparation. [[Link](#)]
- Study Mind. (2023, March 29). Reasons to use Deuterated Solvents in Nuclear Magnetic Resonance Spectroscopy. [[Link](#)]
- Cerno Bioscience. Isotope Labeling. [[Link](#)]
- Cole-Parmer. Material Safety Data Sheet - Methyl Benzoylformate, 99%. [[Link](#)]

Need Custom Synthesis?

BenchChem offers custom synthesis for rare earth carbides and specific isotopic labeling.

Email: info@benchchem.com or [Request Quote Online](#).

Sources

- [1. Deuterated Solvents for NMR: Guide - Allan Chemical Corporation | allanchem.com \[allanchem.com\]](#)
- [2. NMR Sample Preparation | College of Science and Engineering \[cse.umn.edu\]](#)
- [3. depts.washington.edu \[depts.washington.edu\]](#)
- [4. NMR Sample Preparation | Chemical Instrumentation Facility \[cif.iastate.edu\]](#)
- [5. NP-MRD: 1H NMR Spectrum \(1D, 900 MHz, H2O, predicted\) \(NP0239650\) \[np-mrd.org\]](#)
- [6. Deuterium NMR - Wikipedia \[en.wikipedia.org\]](#)
- [7. sigmaaldrich.com \[sigmaaldrich.com\]](#)
- [8. Isotopic labeling - Wikipedia \[en.wikipedia.org\]](#)
- [9. researchgate.net \[researchgate.net\]](#)
- [10. chromatographyonline.com \[chromatographyonline.com\]](#)
- [11. Methyl benzoylformate: properties, applications and safety_Chemicalbook \[chemicalbook.com\]](#)
- [12. chemscene.com \[chemscene.com\]](#)
- [13. Methyl Benzoylformate | CymitQuimica \[cymitquimica.com\]](#)
- [To cite this document: BenchChem. \[spectroscopic data for D3-METHYL BENZOYLFORMATE\]. BenchChem, \[2026\]. \[Online PDF\]. Available at: \[https://www.benchchem.com/product/b591370/docs#spectroscopic-data-for-d3-methyl-benzoylformate\]](#)

Disclaimer & Data Validity:

The information provided in this document is for Research Use Only (RUO) and is strictly not intended for diagnostic or therapeutic procedures. While BenchChem strives to provide accurate protocols, we make no warranties, express or implied, regarding the fitness of this product for every specific experimental setup.

Technical Support: The protocols provided are for reference purposes. Unsure if this reagent suits your experiment?

Need Industrial/Bulk Grade? [Request Custom Synthesis Quote](#)

BenchChem

Our mission is to be the trusted global source of essential and advanced chemicals, empowering scientists and researchers to drive progress in science and industry.

Contact

Address: 3281 E Guasti Rd

Ontario, CA 91761, United States

Phone: (601) 213-4426

Email: info@benchchem.com

[Contact our Ph.D. Support Team for a compatibility check](#)