

An In-Depth Technical Guide to R-Octopamine Hydrochloride

Author: BenchChem Technical Support Team. **Date:** May 2026

Compound of Interest

Compound Name:	(R)-4-(1-Amino-2-hydroxyethyl)phenol hydrochloride
CAS No.:	1391355-45-5
Cat. No.:	B591918

[Get Quote](#)

For Researchers, Scientists, and Drug Development Professionals

Authored by a Senior Application Scientist

This guide provides a comprehensive technical overview of R-octopamine hydrochloride, a specific stereoisomer of the biogenic amine octopamine. Recognizing the critical role of stereochemistry in pharmacology and drug development, this document focuses exclusively on the R-enantiomer, offering detailed insights into its chemical identity, synthesis, pharmacological actions, and analytical characterization.

Section 1: Chemical Identity and Physicochemical Properties

R-octopamine, the R-enantiomer of 4-(2-amino-1-hydroxyethyl)phenol, is a crucial endogenous neuromodulator in invertebrates, functionally analogous to norepinephrine in vertebrates.^[1] Its hydrochloride salt is the common form utilized in research due to its stability and solubility.

Chemical Identifiers:

- Chemical Name: (R)-4-(2-Amino-1-hydroxyethyl)phenol hydrochloride

- CAS Number: 19462-08-9
- Molecular Formula: $C_8H_{11}NO_2 \cdot HCl$
- Molecular Weight: 189.64 g/mol

It is critical to distinguish the R-enantiomer from the racemic mixture, (\pm)-octopamine hydrochloride, which has a different CAS number (770-05-8).

Physicochemical Data:

Property	Value	Source
Appearance	White to off-white crystalline powder	[2]
Solubility	Soluble in water	[2]
Storage	Store in a cool, dry, well-ventilated area. Keep containers tightly sealed.[2]	
Stability	Stable under normal conditions.[3]	

Section 2: Synthesis and Chiral Resolution

The biological activity of octopamine is highly dependent on its stereochemistry. Therefore, obtaining enantiomerically pure R-octopamine is paramount for accurate pharmacological studies. This can be achieved through stereospecific synthesis or by resolving the racemic mixture.

Stereospecific Synthesis

While various methods exist for the synthesis of racemic octopamine, the stereospecific synthesis of the R-enantiomer often involves chiral catalysts or starting materials. One patented method describes the synthesis of (S)-octopamine (the enantiomer of the topic) starting from p-hydroxybenzaldehyde and nitromethane using a chiral catalyst, which could potentially be adapted for the synthesis of the R-enantiomer by using the opposite enantiomer of the chiral ligand.[4] The process involves the formation of a chiral nitroalkanol intermediate, followed by reduction of the nitro group to an amine.[4]

Chiral Resolution of Racemic Octopamine

A common and practical approach to obtaining R-octopamine is through the chiral resolution of a racemic mixture. This technique leverages the formation of diastereomeric salts with a chiral resolving agent, which can then be separated by their differing physical properties, such as solubility.^[5] Tartaric acid is a frequently used and cost-effective resolving agent for amines like octopamine.^{[2][6]}

Exemplary Protocol for Chiral Resolution using (+)-Tartaric Acid:

This protocol is based on established principles of diastereomeric salt formation and crystallization.^{[2][5][6]}

- **Salt Formation:** Dissolve the racemic (\pm)-octopamine hydrochloride in a suitable solvent, such as methanol. In a separate container, dissolve an equimolar amount of a chiral resolving agent, for example, (+)-tartaric acid, in the same solvent.
- **Crystallization:** Slowly combine the two solutions. The diastereomeric salts will have different solubilities, leading to the preferential crystallization of one diastereomer. For instance, the salt of (R)-octopamine with (+)-tartaric acid may be less soluble and precipitate out of the solution. The mixture should be allowed to stand undisturbed to facilitate crystal growth.^[7]
- **Isolation:** The precipitated diastereomeric salt is collected by filtration and washed with a small amount of cold solvent to remove impurities.
- **Liberation of the Free Base:** The isolated diastereomeric salt is then treated with a base (e.g., sodium hydroxide) to neutralize the tartaric acid and liberate the free R-octopamine.
- **Conversion to Hydrochloride Salt:** The purified R-octopamine free base can then be converted to the hydrochloride salt by treatment with hydrochloric acid.

Workflow for Chiral Resolution:

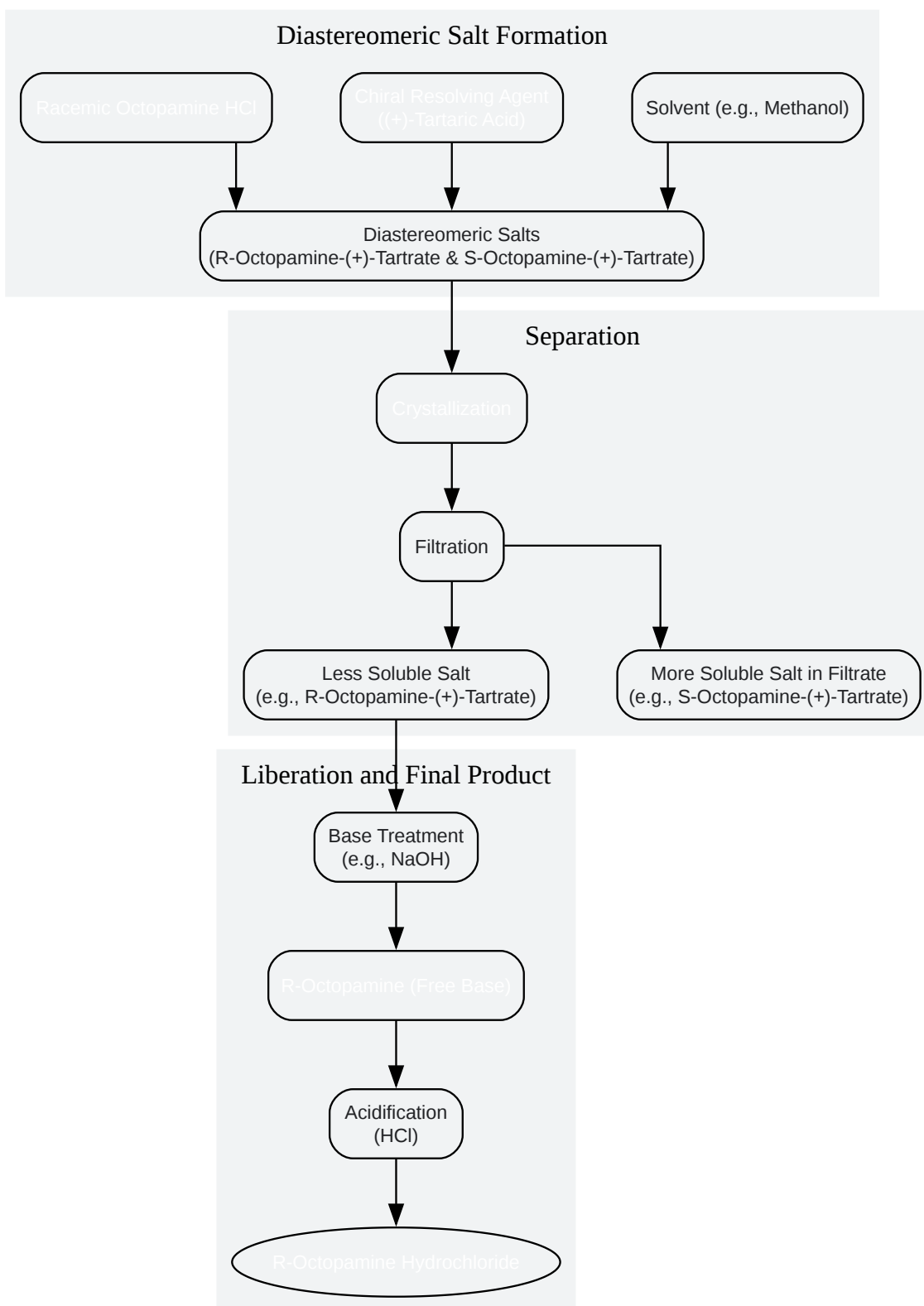

[Click to download full resolution via product page](#)

Caption: Workflow for the chiral resolution of racemic octopamine.

Section 3: Pharmacology and Mechanism of Action

R-octopamine is a key neuromodulator in invertebrates, playing a role in a wide array of physiological processes, including the "fight-or-flight" response, learning, and memory.^{[5][8]} Its effects are mediated through binding to specific G-protein coupled receptors (GPCRs).

Octopamine Receptors

There are several subtypes of octopamine receptors, broadly classified into alpha-adrenergic-like (Oct α R) and beta-adrenergic-like (Oct β R) receptors, as well as a third class that can also bind tyramine (Oct/TyrR).^[9]

- Oct α R: Activation of these receptors typically leads to an increase in intracellular calcium levels ($[Ca^{2+}]_i$).^{[6][10]}
- Oct β R: These receptors are generally coupled to the activation of adenylyl cyclase, resulting in an increase in intracellular cyclic AMP (cAMP) levels.^{[9][10]}
- Oct/TyrR: This class of receptors can be activated by both octopamine and its precursor, tyramine.

Signaling Pathways

The binding of R-octopamine to its cognate GPCRs initiates a cascade of intracellular events. For Oct β R, the activated G-protein stimulates adenylyl cyclase, which converts ATP to cAMP. cAMP then acts as a second messenger, activating protein kinase A (PKA), which in turn phosphorylates various downstream targets to elicit a physiological response. For Oct α R, the activated G-protein stimulates phospholipase C (PLC), which cleaves phosphatidylinositol 4,5-bisphosphate (PIP₂) into inositol trisphosphate (IP₃) and diacylglycerol (DAG). IP₃ binds to receptors on the endoplasmic reticulum, triggering the release of stored Ca²⁺ into the cytoplasm.

Signaling Pathway of R-Octopamine at an Oct β Receptor:

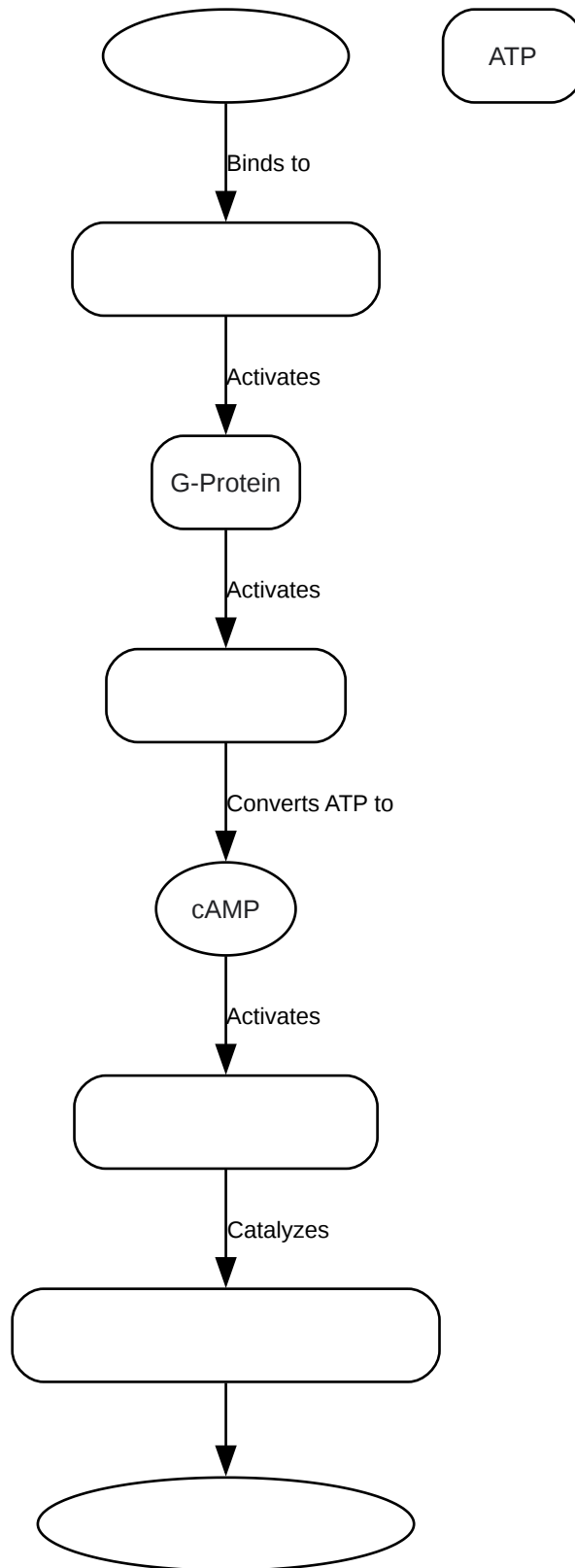

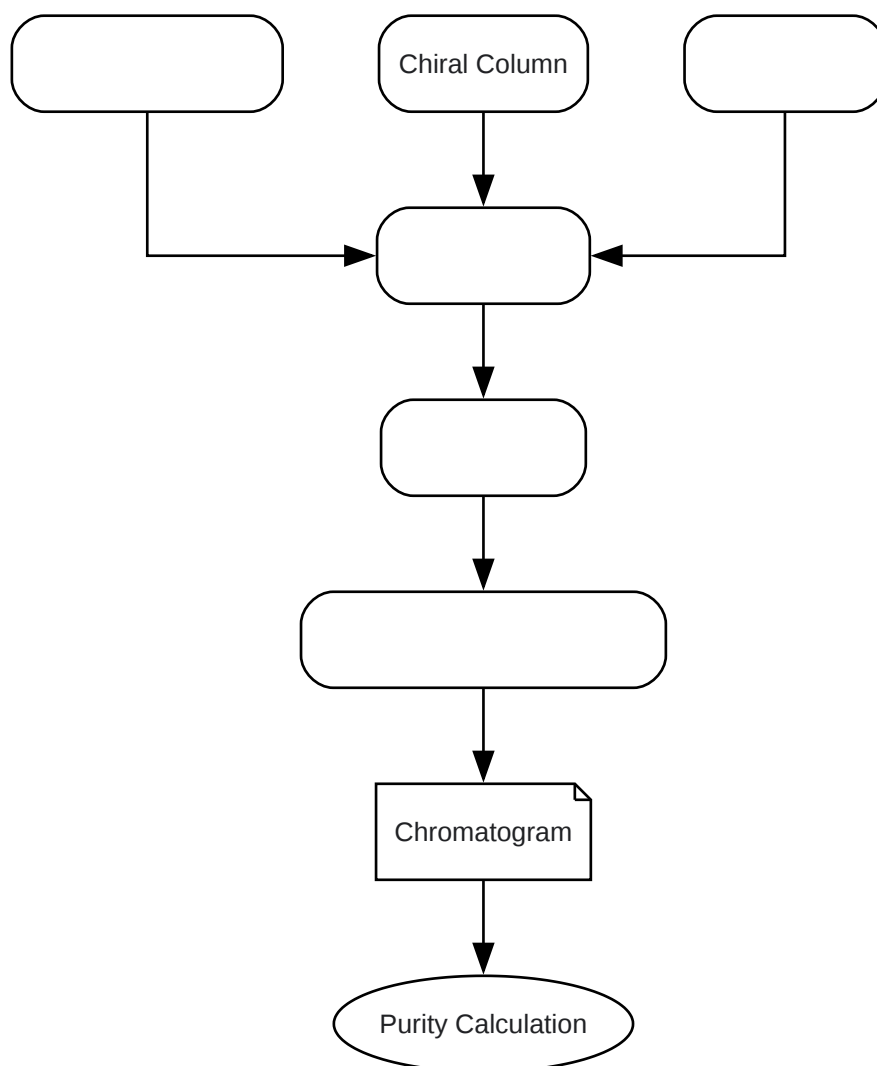

[Click to download full resolution via product page](#)

Need Custom Synthesis?

BenchChem offers custom synthesis for rare earth carbides and specific isotopic labeling.

Email: info@benchchem.com or [Request Quote Online](#).

Sources

- [1. Q1 Stability Testing of Drug Substances and Drug Products | FDA \[fda.gov\]](#)
- [2. pdf.benchchem.com \[pdf.benchchem.com\]](#)
- [3. researchgate.net \[researchgate.net\]](#)

- [4. CN102059145A - Catalyst, method for synthesizing \(S\)-octopamine and method for synthesizing \(S\)-N-trans-feruloyloctopamine - Google Patents \[patents.google.com\]](#)
- [5. rsc.org \[rsc.org\]](#)
- [6. chem.libretexts.org \[chem.libretexts.org\]](#)
- [7. sciencelearningcenter.pbworks.com \[sciencelearningcenter.pbworks.com\]](#)
- [8. mdpi.com \[mdpi.com\]](#)
- [9. CN102381991A - Method for synthesizing DL-Octopamine hydrochloride - Google Patents \[patents.google.com\]](#)
- [10. pubs.acs.org \[pubs.acs.org\]](#)
- [To cite this document: BenchChem. \[An In-Depth Technical Guide to R-Octopamine Hydrochloride\]. BenchChem, \[2026\]. \[Online PDF\]. Available at: \[https://www.benchchem.com/product/b591918/docs#an-in-depth-technical-guide-to-r-octopamine-hydrochloride\]](#)

Disclaimer & Data Validity:

The information provided in this document is for Research Use Only (RUO) and is strictly not intended for diagnostic or therapeutic procedures. While BenchChem strives to provide accurate protocols, we make no warranties, express or implied, regarding the fitness of this product for every specific experimental setup.

Technical Support: The protocols provided are for reference purposes. Unsure if this reagent suits your experiment?

Need Industrial/Bulk Grade? [Request Custom Synthesis Quote](#)

BenchChem

Our mission is to be the trusted global source of essential and advanced chemicals, empowering scientists and researchers to drive progress in science and industry.

- Contact
- Address: 3281 E Guasti Rd
Ontario, CA 91761, United States
- Phone: (601) 213-4426
- Email: info@benchchem.com

[Contact our Ph.D. Support Team for a compatibility check](#)