

Technical Support Center: Thiovardenafil ESI Source Optimization

Author: BenchChem Technical Support Team. **Date:** March 2026

Compound of Interest

Compound Name: Thiovardenafil

CAS No.: 912576-24-0

Cat. No.: B590386

[Get Quote](#)

Case ID: TV-ESI-OPT-001 Status: Open Assigned Specialist: Senior Application Scientist, Mass Spectrometry Division

Welcome to the Advanced Applications Support Center

You have reached the specialized support tier for PDE-5 inhibitor analysis. Below is the technical dossier for optimizing Electrospray Ionization (ESI) parameters specifically for **Thiovardenafil** (Thiocarbonyl vardenafil).

Unlike its parent compound Vardenafil, **Thiovardenafil** contains a thiocarbonyl group () replacing the carbonyl oxygen (

). This structural modification alters its proton affinity, lipophilicity, and thermal stability, necessitating a distinct optimization strategy to prevent in-source degradation and maximize sensitivity.

Module 1: Pre-Source Chemistry & Ionization Physics

Q: What is the target ionization state for **Thiovardenafil**, and how does the thiocarbonyl group affect my polarity choice?

A: You must operate in ESI Positive Mode (+). **Thiovardenafil** (C₂₃H₃₂N₆O₃S₂) has a molecular weight of 504.6 Da, resulting in a protonated precursor ion

at m/z 505.2.

- Mechanism: The piperazine ring nitrogen remains the primary site of protonation. However, the sulfur atom in the thiocarbonyl group is "softer" and more polarizable than oxygen. This increases the molecule's surface activity in the ESI droplet but also makes it more susceptible to oxidation if the source conditions are too aggressive.
- Critical Distinction: Do not confuse this with Vardenafil (). The mass shift of +16 Da (O S) is your primary confirmation of the thio-analog.

Q: My signal is unstable. What mobile phase composition do you recommend?

A: Use a Methanol/Water system with 0.1% Formic Acid.

- Why Methanol? Thio-analogs generally exhibit higher solubility and ionization efficiency in protic organic solvents like methanol compared to acetonitrile. Methanol also provides a more stable spray at lower capillary voltages.
- Why Acidic pH? The basic nitrogen in the piperazine ring requires a pH 3.0 to ensure full protonation.
- Warning: Avoid high concentrations of Ammonium Formate (>5mM) if possible, as it can suppress the signal for this specific hydrophobic analog.

Module 2: Source Parameter Optimization (Step-by-Step)

Q: How do I determine the optimal Source Temperature and Desolvation Gas Flow?

A: Thiovaridenafil is thermally labile. The

bond is weaker than

, making the molecule prone to desulfurization (reverting to Vardenafil, m/z 489) or oxidation in the source.

Protocol:

- Start Low: Set Source Temp to 100°C and Desolvation Temp to 350°C.
- Ramp Gas Flow: Increase Desolvation Gas (Nitrogen) from 600 L/hr to 1000 L/hr.
 - Observation: Higher gas flow aids droplet evaporation without adding excessive thermal energy.
- Ramp Temperature: Incrementally increase Desolvation Temp in 25°C steps.
 - Stop Point: When the signal for m/z 505 plateaus or if you see the appearance of m/z 489 (degradation product).

Q: What is the correct Capillary and Cone Voltage setting?

A: This is the most critical step. High energy causes "In-Source Fragmentation" (ISF).

- Capillary Voltage (kV): **Thioildenafil** ionizes efficiently at lower voltages due to its surface activity.
 - Recommended: 2.5 – 3.0 kV. (Standard Vardenafil methods often use 3.5 kV, which is too high for the Thio-analog).
- Cone Voltage / Declustering Potential (V):
 - Risk:^[1]^[2] Excessive cone voltage will strip the sulfur or break the piperazine ring before the quadrupole.
 - Target: 20 – 30 V. Perform a ramp; if you see m/z 151 (piperazine fragment) in the MS1 scan, your voltage is too high.

Summary of Starting Conditions:

Parameter	Setting	Rationale
Polarity	ESI Positive (+)	Basic piperazine nitrogen protonation.
Precursor Ion	m/z 505.2	(Distinct from Vardenafil m/z 489).
Capillary Voltage	2.8 kV	Prevent discharge; protect labile S-bond.
Cone Voltage	25 V	Minimize in-source fragmentation.
Source Temp	120°C	Prevent thermal degradation.
Desolvation Temp	400°C	Ensure droplet evaporation.
Desolvation Gas	800 L/hr (N ₂)	Pneumatic assistance for ionization.

Module 3: Optimization Workflow Visualization

The following diagram illustrates the logical flow for tuning your instrument specifically for **Thiovaridenafil**.

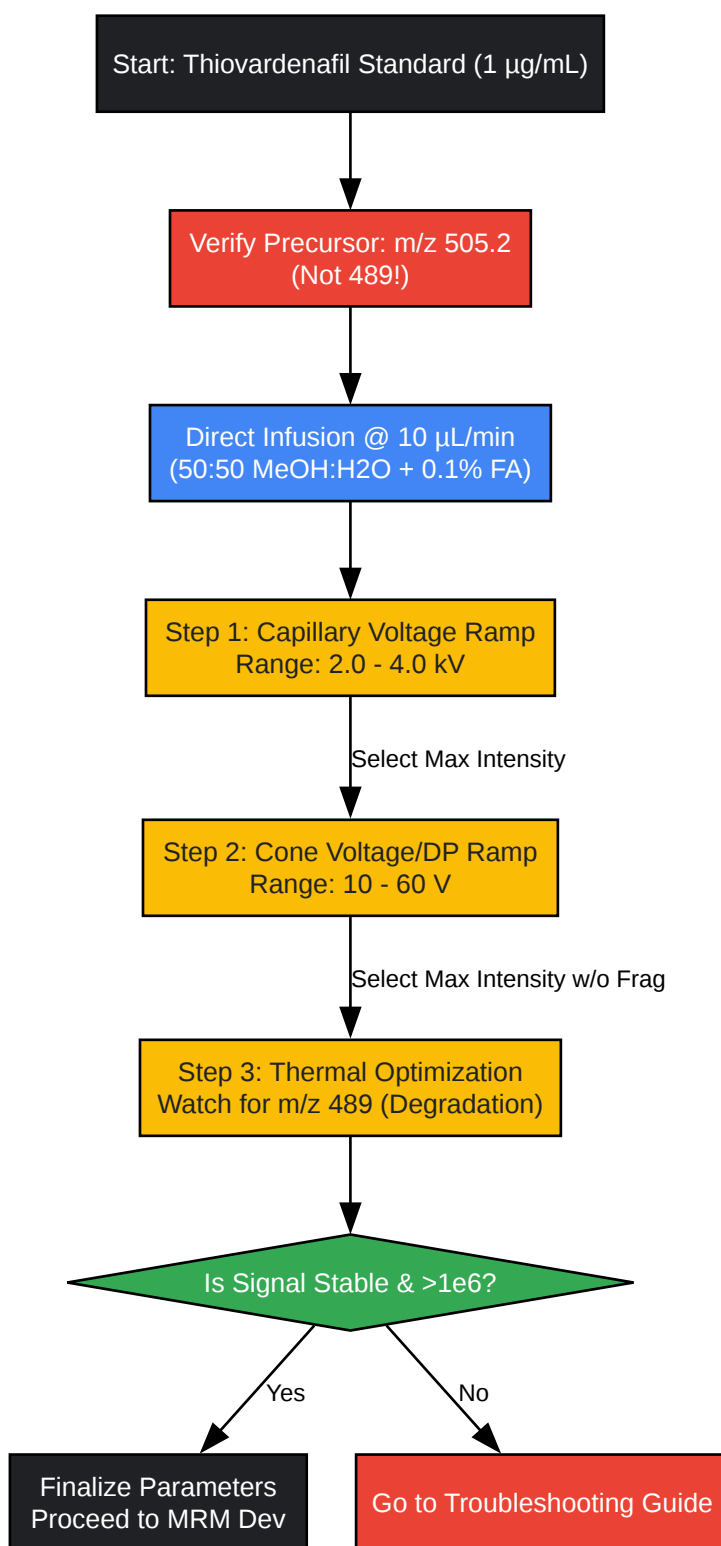

[Click to download full resolution via product page](#)

Figure 1: Step-by-step optimization logic for **Thiovaridenafil**. Note the critical check for thermal degradation products (m/z 489).

Module 4: Troubleshooting & FAQs

Q: I see a strong signal at m/z 489 instead of 505. What is happening?

A: You are witnessing Desulfurization. This occurs when the bond is replaced by (oxidative desulfurization).

- Cause 1: Source temperature is too high (>450°C).
- Cause 2: Contaminated mobile phase (oxidizing agents present).
- Cause 3: Sample degradation during storage. **Thioildenafil** is light-sensitive; ensure samples are stored in amber vials at -20°C.

Q: What are the best MRM transitions for quantification?

A: Thio-analogs exhibit a unique rearrangement where the alkyl group transfers from the piperazine nitrogen to the thiocarbonyl sulfur [1].

- Primary Transition (Quant):505.2
299.1 (Cleavage of the piperazine ring).
- Secondary Transition (Qual):505.2
151.1 (Piperazine fragment).
- Note: The 151 fragment is common to Vardenafil, Sildenafil, and **Thioildenafil**. Use the 299 fragment for specificity.

Q: My linearity is poor at low concentrations.

A: This is often due to adsorption. **Thioildenafil** is lipophilic.

- Fix: Use "Low-Bind" polypropylene vials and inserts.

- Fix: Ensure your needle wash solvent contains at least 50% Methanol/Isopropanol to prevent carryover.

Module 5: Diagnostic Logic Tree

Use this decision tree when encountering signal loss or high background.

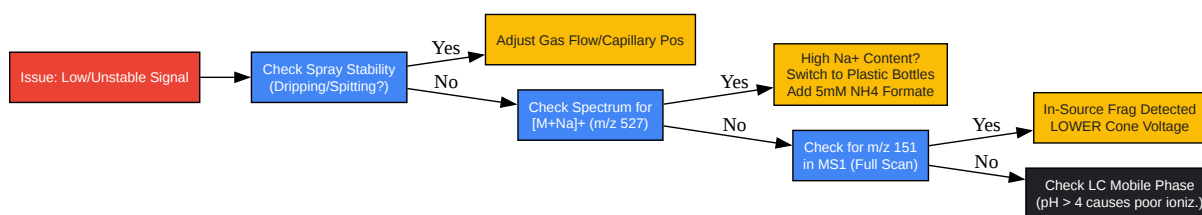

[Click to download full resolution via product page](#)

Figure 2: Diagnostic decision tree for resolving common ESI ionization failures with Thiovaridenafil.

References

- Reepmeyer, J. C., & Woodruff, J. T. (2009). Direct intramolecular gas-phase transfer reactions during fragmentation of sildenafil and thiosildenafil analogs in electrospray ionization mass spectrometry. *Rapid Communications in Mass Spectrometry*.
- Lee, J. H., et al. (2021).[1] Detection of 94 compounds related to sexual enhancement including sildenafil, tadalafil, vardenafil and their analogues in various formulations of dietary supplements and food samples using HPLC and LC-MS/MS. *Food Additives & Contaminants: Part A*.
- Element Lab Solutions. (n.d.). 10 Tips for Electrospray Ionisation LC-MS.
- National Center for Biotechnology Information. (2025). PubChem Compound Summary for Vardenafil. (Used for structural comparison logic).

Need Custom Synthesis?

BenchChem offers custom synthesis for rare earth carbides and specific isotopic labeling.

Email: info@benchchem.com or [Request Quote Online](#).

Sources

- 1. Detection of 94 compounds related to sexual enhancement including sildenafil, tadalafil, vardenafil and their analogues in various formulations of dietary supplements and food samples using HPLC and LC-MS/MS - PubMed [pubmed.ncbi.nlm.nih.gov]
- 2. dusekm.tripod.com [dusekm.tripod.com]
- To cite this document: BenchChem. [Technical Support Center: Thiovaridenafil ESI Source Optimization]. BenchChem, [2026]. [Online PDF]. Available at: [<https://www.benchchem.com/product/b590386#optimizing-esi-source-parameters-for-thiovaridenafil-ionization>]

Disclaimer & Data Validity:

The information provided in this document is for Research Use Only (RUO) and is strictly not intended for diagnostic or therapeutic procedures. While BenchChem strives to provide accurate protocols, we make no warranties, express or implied, regarding the fitness of this product for every specific experimental setup.

Technical Support: The protocols provided are for reference purposes. Unsure if this reagent suits your experiment? [[Contact our Ph.D. Support Team for a compatibility check](#)]

Need Industrial/Bulk Grade? [Request Custom Synthesis Quote](#)

BenchChem

Our mission is to be the trusted global source of essential and advanced chemicals, empowering scientists and researchers to drive progress in science and industry.

Contact

Address: 3281 E Guasti Rd

Ontario, CA 91761, United States

Phone: (601) 213-4426

Email: info@benchchem.com