

# Technical Support Center: Optimizing (S)-7-Hydroxywarfarin Fluorescence Detection

**Author:** BenchChem Technical Support Team. **Date:** April 2026

## Compound of Interest

Compound Name: (S)-7-Hydroxywarfarin

CAS No.: 63740-81-8

Cat. No.: B590326

[Get Quote](#)

Welcome to the technical support center for the sensitive detection of **(S)-7-hydroxywarfarin**. This guide is designed for researchers, scientists, and drug development professionals to provide expert, field-proven insights into overcoming common challenges, with a primary focus on reducing background noise to enhance assay sensitivity and data quality.

The conversion of (S)-warfarin to its primary metabolite, **(S)-7-hydroxywarfarin**, is a key reaction catalyzed by the cytochrome P450 enzyme CYP2C9.<sup>[1][2]</sup> Fluorescence-based assays offer a highly sensitive method for monitoring this enzymatic activity, crucial for drug metabolism studies and inhibitor screening.<sup>[3][4]</sup> However, the accuracy of these assays is often compromised by high background fluorescence. This guide provides a structured approach to diagnosing and mitigating these issues.

## Frequently Asked Questions (FAQs)

Q1: What are the optimal excitation and emission wavelengths for **(S)-7-hydroxywarfarin** detection?

While warfarin itself has reported excitation and emission wavelengths of 310 nm and 390 nm respectively, the hydroxylated metabolite, 7-hydroxywarfarin, exhibits different spectral properties.[5][6] For assays involving coumarin-based derivatives, which are structurally similar, excitation is often in the 405-415 nm range with emission around 450-502 nm.[7][8] It is crucial to empirically determine the optimal wavelengths for your specific instrument and buffer conditions by running excitation and emission scans of a purified **(S)-7-hydroxywarfarin** standard.

Q2: What are the most common sources of background noise in my assay?

Background fluorescence, or noise, can originate from multiple sources which can be broadly categorized into two main areas: instrumental and sample-related.[9]

- Instrumental: This includes noise from the light source and detector of the microplate reader. [9]
- Sample-related: This is often the more significant and variable source, including:
  - Autofluorescence: Intrinsic fluorescence from biological molecules in your sample (e.g., proteins, NADH), cell culture media components (e.g., phenol red, fetal bovine serum), or the test compounds themselves.[10][11][12]
  - Reagent Fluorescence: The substrate or other assay components may have some intrinsic fluorescence.
  - Microplate Material: Plastic-bottom plates can be highly fluorescent.[9]
  - Light Scatter: Particulate matter in the sample can scatter excitation light into the emission channel.

Q3: Which type of microplate is best for this fluorescence assay?

For fluorescence intensity assays, opaque black microplates are the standard recommendation.[10] The black plastic minimizes background by quenching stray light and reducing crosstalk between wells, which significantly improves the signal-to-blank ratio compared to clear or white plates.[10][13] If working with adherent cells, black-walled, clear-bottom plates are necessary for bottom-reading instruments.

Q4: How can I confirm if my test compound is interfering with the assay?

Test compound interference is a common issue in drug discovery screening.[12] Compounds can interfere by being fluorescent themselves, quenching the signal of the 7-hydroxywarfarin product, or through the inner filter effect.[14][15] To test for this, run parallel control experiments:

- **Compound Autofluorescence:** Incubate the test compound in the assay buffer without the enzyme or substrate and measure the fluorescence at the assay wavelengths.
- **Quenching/Enhancement:** Incubate the test compound with a known concentration of the fluorescent product, **(S)-7-hydroxywarfarin**, in the absence of the enzyme and substrate. A decrease or increase in signal compared to the product alone indicates interference.

## Troubleshooting Guide: From High Blanks to Low Signal

This section provides a systematic approach to identifying and resolving specific issues encountered during **(S)-7-hydroxywarfarin** fluorescence detection.

### Problem 1: High Blank Readings

High fluorescence in your "no enzyme" or "no substrate" control wells can obscure the true signal from the enzymatic reaction.

#### Potential Causes & Diagnostic Steps:

- **Autofluorescence from Media and Buffers:** Components like phenol red and serum in cell culture media are known to be fluorescent.[10][11]
  - **Diagnosis:** Measure the fluorescence of your complete assay buffer and each individual component.
  - **Solution:** If possible, switch to a phenol red-free medium or a specialized low-fluorescence medium for the final assay reading.[11] If serum is a necessary component, try reducing its concentration. For biochemical assays, ensure all buffer components are of high purity.

- Contaminated Reagents: Impurities in substrates, cofactors (e.g., NADPH), or buffer salts can contribute to background.
  - Diagnosis: Prepare blanks systematically, omitting one component at a time to identify the source.
  - Solution: Use high-purity, fluorescence-free reagents. Prepare fresh solutions and store them protected from light.
- Inappropriate Microplate Choice: Using clear or white plates for fluorescence assays will result in high background and well-to-well crosstalk.[\[10\]](#)
  - Diagnosis: This is evident if the background signal is uniformly high across the plate.
  - Solution: Always use opaque, black-walled microplates for fluorescence intensity measurements to minimize background.[\[10\]](#)[\[13\]](#)

## Workflow for Diagnosing High Blanks

Caption: Troubleshooting workflow for high blank readings.

## Problem 2: Poor Signal-to-Noise Ratio (S/N)

A low S/N ratio, where the signal from the positive control is not significantly higher than the background, makes it difficult to detect weak enzymatic activity or inhibition.

### Potential Causes & Diagnostic Steps:

- Sub-optimal Enzyme or Substrate Concentrations: If concentrations are too low, the amount of fluorescent product generated will be insufficient.
  - Diagnosis: Run a matrix of enzyme and substrate concentrations to find the optimal conditions that yield a robust linear reaction rate.
  - Solution: Refer to the detailed protocol below for optimizing reaction conditions. Ensure the reaction remains within the linear range for the duration of the measurement.[\[7\]](#)
- Incorrect Instrument Settings (Gain, Focal Height): An improperly set gain can lead to either saturation of the detector (if too high) or weak signal detection (if too low). For adherent cells,

incorrect focal height will reduce signal.

- **Diagnosis:** The signal may appear flat or maxed out across all positive wells.
- **Solution:** Use a positive control well (containing a high concentration of product or an uninhibited enzyme reaction) to set the gain. The goal is to maximize the signal without saturating the detector.[10] For cell-based assays, perform a focal height adjustment.[13]
- **Inner Filter Effect (IFE):** At high concentrations, the substrate or other components in the well can absorb the excitation light or the emitted fluorescence, leading to a non-linear decrease in the detected signal.[14]
  - **Diagnosis:** The fluorescence signal may plateau or even decrease at higher product concentrations.
  - **Solution:** Work with lower, non-absorbing concentrations of substrate and product. If necessary, generate a correction curve by measuring the fluorescence of a standard in the presence of varying concentrations of the interfering substance.

## Visualizing the Inner Filter Effect

Caption: The inner filter effect reduces detected fluorescence.

## Problem 3: Interference from Test Compounds

Test compounds can generate false positives or false negatives by directly interfering with the fluorescence signal.

### Potential Causes & Diagnostic Steps:

- **Compound Autofluorescence:** The test compound itself fluoresces at the assay's excitation/emission wavelengths.[12]
  - **Diagnosis:** As described in the FAQs, measure the fluorescence of the compound in assay buffer alone.
  - **Solution:** If the compound is fluorescent, consider using a different assay format (e.g., LC-MS/MS). Alternatively, if the interference is low, it can be subtracted from the test wells, but

this increases variability. Another option is to use red-shifted dyes if possible, as compound autofluorescence is often more pronounced in the blue-green spectrum.[11]

- Fluorescence Quenching: The test compound reduces the fluorescence of the 7-hydroxywarfarin product through mechanisms like collisional quenching or FRET.[15][16]
  - Diagnosis: Incubate the compound with a known amount of 7-hydroxywarfarin. A signal decrease indicates quenching.
  - Solution: This is a challenging issue. The most reliable solution is to confirm hits using an orthogonal assay with a different detection method (e.g., absorbance or mass spectrometry).[12]

### Data Summary: Common Sources of Interference

Source of Interference	Spectral Region	Recommended Action
Phenol Red	Excitation: ~440 nm, Emission: ~570 nm	Use phenol red-free media for the assay.[11]
Riboflavin (Vitamin B2)	Excitation: ~450 nm, Emission: ~530 nm	Use specialized low-fluorescence media.
Tryptophan (in proteins)	Excitation: ~280 nm, Emission: ~350 nm	Use appropriate blank controls; typically less of an issue with Ex >400 nm.
Test Compounds	Varies widely	Screen for autofluorescence and quenching; confirm hits with an orthogonal assay.[12]

## Key Experimental Protocols

### Protocol 1: Optimizing Enzyme and Substrate Concentrations

Objective: To determine the concentrations of CYP2C9 and (S)-warfarin that result in a robust, linear rate of product formation.

- Enzyme Titration:

- Prepare a series of dilutions of your enzyme source (e.g., human liver microsomes or recombinant CYP2C9) in reaction buffer (e.g., 100 mM potassium phosphate buffer, pH 7.4).[1]
- Add a fixed, saturating concentration of (S)-warfarin substrate.
- Initiate the reaction by adding an NADPH-generating system.[1]
- Monitor fluorescence over time in kinetic mode.[7]
- Select an enzyme concentration that gives a strong linear rate for at least 30-60 minutes.
- Substrate Titration (Michaelis-Menten Kinetics):
  - Using the optimal enzyme concentration determined above, prepare a series of (S)-warfarin dilutions (e.g., 0.5 to 50  $\mu\text{M}$ ).[1]
  - Initiate the reactions and monitor the initial reaction velocity ( $V_0$ ) for each substrate concentration.
  - Plot  $V_0$  versus substrate concentration and fit the data to the Michaelis-Menten equation to determine  $K_m$  and  $V_{max}$ . For inhibition studies, a substrate concentration at or below the  $K_m$  value is typically used to maximize sensitivity to competitive inhibitors.

## Protocol 2: Screening for Test Compound Interference

Objective: To identify compounds that interfere with the fluorescence detection method.

- Assay Plate Setup: Design a plate map that includes the following controls for each test compound:
  - Test Well: Enzyme + Substrate + NADPH + Test Compound
  - Negative Control (No Enzyme): Substrate + NADPH + Test Compound
  - Autofluorescence Control: Buffer + NADPH + Test Compound
  - Quenching Control: Purified 7-hydroxywarfarin product + Test Compound

- Procedure:
  - Dispense reagents according to the plate map.
  - Pre-incubate the enzyme with the test compound for a defined period (e.g., 15 minutes) before adding the substrate.
  - Initiate the reaction with the NADPH-generating system.
  - Read the plate on a fluorescence microplate reader at the optimal excitation and emission wavelengths.
- Data Analysis:
  - Subtract the signal from the "Autofluorescence Control" from all other wells containing that compound.
  - Compare the signal in the "Quenching Control" to a control well with only the 7-hydroxywarfarin product. A significant decrease indicates quenching.
  - Calculate the percent inhibition in the "Test Well" relative to a vehicle control (no compound). Hits that also show significant autofluorescence or quenching should be flagged for follow-up in an orthogonal assay.

## Metabolic Pathway and Assay Principle

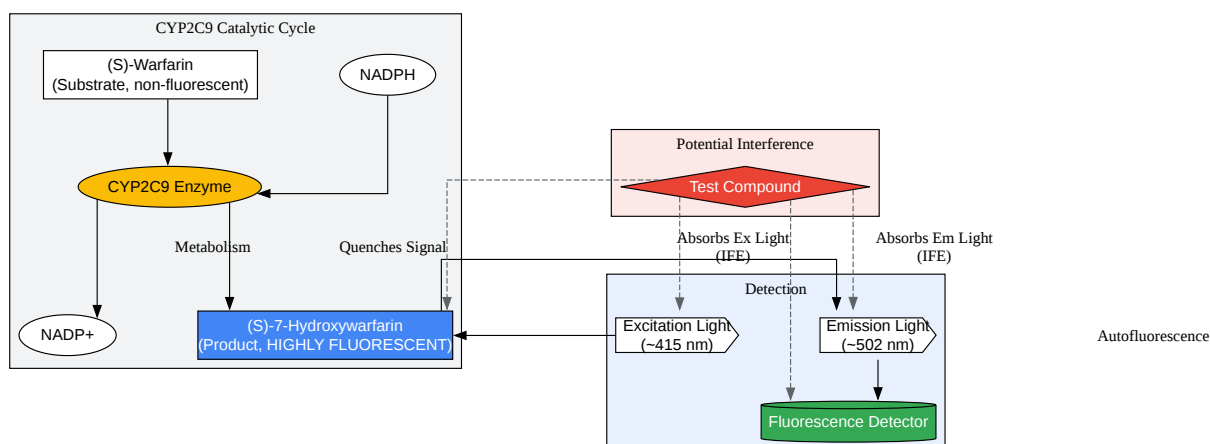

[Click to download full resolution via product page](#)

Caption: Assay principle for **(S)-7-hydroxywarfarin** formation and points of interference.

By systematically applying these troubleshooting principles and protocols, researchers can significantly improve the quality and reliability of their **(S)-7-hydroxywarfarin** fluorescence detection assays, leading to more accurate characterization of CYP2C9 activity and inhibition.

## References

- BMG LABTECH. (2024, October 2). The Ultimate Guide to Troubleshooting Microplate Assays. Bitesize Bio. [\[Link\]](#)

- Zayed, A., et al. (2020). Simultaneous determination of warfarin and 7-hydroxywarfarin in rat plasma by HPLC-FLD. ResearchGate. [[Link](#)]
- Zayed, A., et al. (2019, September 30). Simultaneous determination of warfarin and 7-hydroxywarfarin in rat plasma by HPLC-FLD. Acta Pharmaceutica. [[Link](#)]
- Miura, M., et al. (2011). Simultaneous Determination of Warfarin and 7-Hydroxywarfarin Enantiomers by High-Performance Liquid Chromatography With Ultraviolet Detection. Therapeutic Drug Monitoring. [[Link](#)]
- BMG Labtech. (n.d.). How to reduce autofluorescence in cell-based assays. [[Link](#)]
- Jones, B. C., et al. (n.d.). Hydroxywarfarin Metabolites Potently Inhibit CYP2C9 Metabolism of S-Warfarin. PMC. [[Link](#)]
- Di Martino, R. M. C., et al. (n.d.). Fluorescence-Based Enzyme Activity Assay: Ascertaining the Activity and Inhibition of Endocannabinoid Hydrolytic Enzymes. PMC. [[Link](#)]
- Eftink, M. R. (n.d.). Protein fluorescence quenching by small molecules. Biophysical Journal.
- ACS Omega. (2024, June 25). Evaluation of Fluorescence-Based Screening Assays for the Detection and Quantification of Silyl Hydrolase Activity. [[Link](#)]
- Fowler, D. M. (2021, July 26). Massively parallel characterization of CYP2C9 variant enzyme activity and abundance. eLife. [[Link](#)]
- ResearchGate. (2017, September 25). Tips for troubleshooting a fluorescence polarization assay for protein-DNA binding?[[Link](#)]
- Edinburgh Instruments. (2024, March 26). What is the Inner Filter Effect and How Does it Impact Fluorescence Measurements?[[Link](#)]
- Visikol. (2022, February 14). Challenges with Background Fluorescence. [[Link](#)]
- Spectral Instruments Imaging. (n.d.). Troubleshooting Guide for BLI & FLI Optical Imaging: A Step-by-Step Approach. [[Link](#)]
- PNAS. (n.d.). Fluorescence quenching: A tool for single-molecule protein-folding study. [[Link](#)]

- Creative Bioarray. (2024, February 28). Troubleshooting in Fluorescent Staining. [[Link](#)]
- Patsnap Synapse. (2025, May 9). How to Use Fluorescence Spectroscopy for Enzyme Activity Assays. [[Link](#)]
- IntechOpen. (2021, August 24). Design and Implementation of High Throughput Screening Assays for Drug Discoveries. [[Link](#)]
- Molecular Biology. (n.d.). Assay Troubleshooting. [[Link](#)]
- MDPI. (2022, May 27). Simultaneous Characterization and Determination of Warfarin and Its Hydroxylation Metabolites in Rat Plasma by Chiral Liquid Chromatography-Tandem Mass Spectrometry. [[Link](#)]
- bioRxiv. (2021, March 14). Massively parallel characterization of CYP2C9 variant enzyme activity and abundance. [[Link](#)]
- ETH Zurich. (n.d.). Fluorescence Quenching. [[Link](#)]
- MDPI. (2022, April 19). Application of a Fluorescence Anisotropy-Based Assay to Quantify Transglutaminase 2 Activity in Cell Lysates. [[Link](#)]
- BellBrook Labs. (2025, November 17). From Lab to Lead: Using Fluorescence Polarization in Drug Development. [[Link](#)]
- ResearchGate. (n.d.).
- Berthold Technologies. (n.d.). Top tips and tricks: Performing assays in microplates. [[Link](#)]
- Wiley Online Library. (2009, July 2). Considerations for the Control of Background Fluorescence in Clinical Flow Cytometry. [[Link](#)]
- USDA. (n.d.). Rapid Enzyme-Based Assays to Detect Banned Substances in Food. [[Link](#)]
- Labcompare. (2025, November 7). How to Get the Best Out of Your Microplate Reader. [[Link](#)]

- NCBI Bookshelf. (2015, December 7). Interference with Fluorescence and Absorbance. [\[Link\]](#)
- ResearchGate. (n.d.). Fluorescence-properties and excited state interactions of 7-hydroxy-4-methylcoumarin laser dye.
- AxisPharm. (2024, September 26). What is fluorescence quenching?[\[Link\]](#)

### Need Custom Synthesis?

BenchChem offers custom synthesis for rare earth carbides and specific isotopic labeling.

Email: [info@benchchem.com](mailto:info@benchchem.com) or [Request Quote Online](#).

## Sources

- 1. [pdf.benchchem.com](https://pdf.benchchem.com) [[pdf.benchchem.com](https://pdf.benchchem.com)]
- 2. [mdpi.com](https://mdpi.com) [[mdpi.com](https://mdpi.com)]
- 3. Fluorescence-Based Enzyme Activity Assay: Ascertain the Activity and Inhibition of Endocannabinoid Hydrolytic Enzymes - PMC [[pubmed.ncbi.nlm.nih.gov](https://pubmed.ncbi.nlm.nih.gov)]
- 4. How to Use Fluorescence Spectroscopy for Enzyme Activity Assays [[synapse.patsnap.com](https://synapse.patsnap.com)]
- 5. [researchgate.net](https://researchgate.net) [[researchgate.net](https://researchgate.net)]
- 6. [hrcak.srce.hr](https://hrcak.srce.hr) [[hrcak.srce.hr](https://hrcak.srce.hr)]
- 7. [content.abcam.com](https://content.abcam.com) [[content.abcam.com](https://content.abcam.com)]
- 8. Spectrum [3-Cyano-7-hydroxycoumarin] | AAT Bioquest [[aatbio.com](https://aatbio.com)]
- 9. 蛍光イメージングにおけるバックグラウンド | Thermo Fisher Scientific - JP [[thermofisher.com](https://thermofisher.com)]
- 10. [bitesizebio.com](https://bitesizebio.com) [[bitesizebio.com](https://bitesizebio.com)]
- 11. [bmglabtech.com](https://bmglabtech.com) [[bmglabtech.com](https://bmglabtech.com)]
- 12. Interference with Fluorescence and Absorbance - Assay Guidance Manual - NCBI Bookshelf [[ncbi.nlm.nih.gov](https://pubmed.ncbi.nlm.nih.gov)]
- 13. [labcompare.com](https://labcompare.com) [[labcompare.com](https://labcompare.com)]

- [14. What is the Inner Filter Effect and How Does it Impact Fluorescence Measurements? | The Labbot Blog \[labbot.bio\]](#)
- [15. What is fluorescence quenching? | AxisPharm \[axispharm.com\]](#)
- [16. ossila.com \[ossila.com\]](#)
- To cite this document: BenchChem. [Technical Support Center: Optimizing (S)-7-Hydroxywarfarin Fluorescence Detection]. BenchChem, [2026]. [Online PDF]. Available at: [<https://www.benchchem.com/product/b590326/docs#technical-support-center-optimizing-s-7-hydroxywarfarin-fluorescence-detection>]

---

### Disclaimer & Data Validity:

The information provided in this document is for Research Use Only (RUO) and is strictly not intended for diagnostic or therapeutic procedures. While BenchChem strives to provide accurate protocols, we make no warranties, express or implied, regarding the fitness of this product for every specific experimental setup.

**Technical Support:** The protocols provided are for reference purposes. Unsure if this reagent suits your experiment?

**Need Industrial/Bulk Grade?** [Request Custom Synthesis Quote](#)

## BenchChem

Our mission is to be the trusted global source of essential and advanced chemicals, empowering scientists and researchers to drive progress in science and industry.

### Contact

Address: 3281 E Guasti Rd  
Ontario, CA 91761, United States  
Phone: (601) 213-4426  
Email: [info@benchchem.com](mailto:info@benchchem.com)

[Contact our Ph.D. Support Team for a compatibility check](#)

