

Technical Support Center: Fluorinated & Hydrocarbon Blend Stabilization

Author: BenchChem Technical Support Team. **Date:** May 2026

Compound of Interest

Compound Name:	Tris[2-(perfluorodecyl)ethyl] Phosphate
CAS No.:	106554-16-9
Cat. No.:	B590017

[Get Quote](#)

Current Status: Online | Senior Application Scientist: Dr. A. Vance

Welcome to the Phase Engineering Support Hub.

You are likely here because your fluorocarbon (FC) and hydrocarbon (HC) blend has phase-separated, or your emulsion has coarsened within hours. This is not a failure of your technique; it is a fundamental thermodynamic challenge known as the "Fluorous Effect."

Fluorocarbons are not just hydrophobic; they are lipophobic (fat-fearing). The extremely low polarizability of the C-F bond means FCs interact weakly with HCs, leading to high interfacial tension (~50 mN/m) and massive miscibility gaps.

Below are the three most common failure modes we see in the field, accompanied by self-validating protocols to mitigate them.

Module 1: The "Molecular Dowel" Strategy

User Issue: "My blend separates immediately after mixing, even with standard surfactants like Pluronics or Tween."

The Diagnosis: Standard hydrocarbon surfactants have "tails" that are miscible with hydrocarbons but incompatible with fluorocarbons. They fail to anchor effectively at the FC interface, leading to rapid coalescence. You are missing a compatibilizer.

The Solution: Semi-Fluorinated Alkanes (SFAs) You must introduce a "primitive surfactant" or "molecular dowel"—specifically a Semi-Fluorinated Alkane (

).^[1]^[2] These diblock molecules possess a perfluorinated segment (

) and a hydrocarbon segment (

).^[1]^[3] They align at the interface, "stitching" the two incompatible phases together.

Protocol: SFA Compatibilization

- Reagent: Select an SFA where the chain lengths match your bulk phases (e.g., for perfluorohexane/decane systems).
- Dosage: 1% to 5% (w/w) relative to the dispersed phase.

Workflow Visualization:

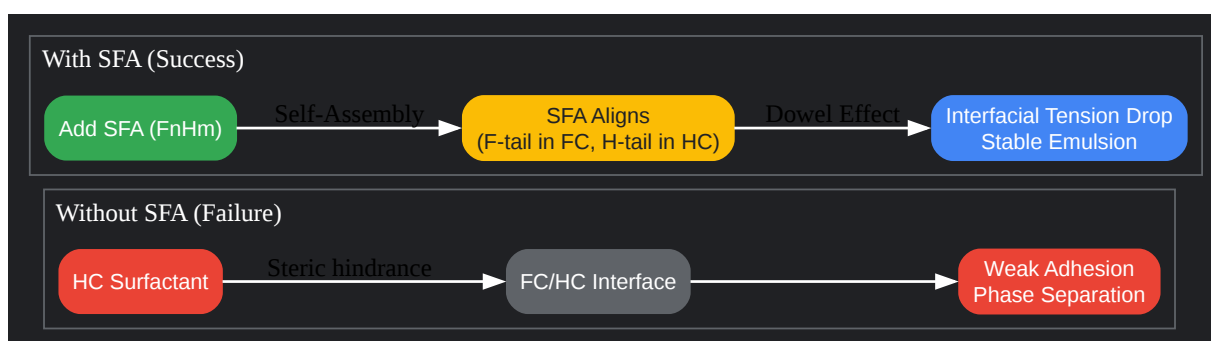

[Click to download full resolution via product page](#)

Figure 1: The "Molecular Dowel" mechanism. SFAs bridge the lipophobic gap that standard surfactants cannot cross.

Module 2: Stopping Ostwald Ripening

User Issue: "My nanoemulsion is stable initially but turns cloudy and separates after 24 hours."

The Diagnosis: This is Ostwald Ripening, the primary degradation mechanism for fluorocarbon emulsions.[4] Because FCs have finite (albeit low) solubility in the continuous phase, smaller droplets diffuse through the continuous phase and deposit onto larger droplets to minimize surface energy.

The Solution: The "Trapped Species" Approach You must add a "ripening inhibitor"—a second fluorocarbon that is significantly less soluble in the continuous phase than your main FC oil. This creates an osmotic pressure gradient that counteracts the Laplace pressure driving the ripening.

Protocol: Ripening Inhibition

- Identify Main Oil: e.g., Perfluorooctyl bromide (PFOB).
- Select Inhibitor: Choose a longer-chain FC or SFA (e.g., Perfluorodecyl bromide or).
- Calculation: Add the inhibitor at a molar fraction () of 0.1 to 0.3 to the dispersed phase before emulsification.

Quantitative Comparison:

Parameter	Unstabilized Emulsion	Stabilized (with Inhibitor)
Mechanism	Diffusion controlled (Ripening)	Osmotically stabilized
Droplet Size ()	to initial size	initial size
Polydispersity Index	Increases rapidly (>0.2)	Remains stable (<0.15)
Key Reference	Kabalnov et al. [3]	Weers et al. [4]

Module 3: Temperature-Induced Separation (UCST)

User Issue: "My blend is a clear single phase at

but turns milky at room temperature."

The Diagnosis: You are encountering the Upper Critical Solution Temperature (UCST).^[5]

Alkane/Perfluoroalkane mixtures have large miscibility gaps that widen as temperature drops.

The Solution: Chain Length Symmetry & Refractive Index Matching

- Symmetry Rule: The miscibility gap is minimized when the molar volumes of the FC and HC components are similar.
 - Correction: If using Perfluorohexane (), pair it with Hexane () rather than Decane () to lower the UCST.
- Visual Check: If the blend becomes cloudy, it has crossed the binodal curve. If it separates instantly, it is likely inside the spinodal region.

Phase Behavior Diagram:

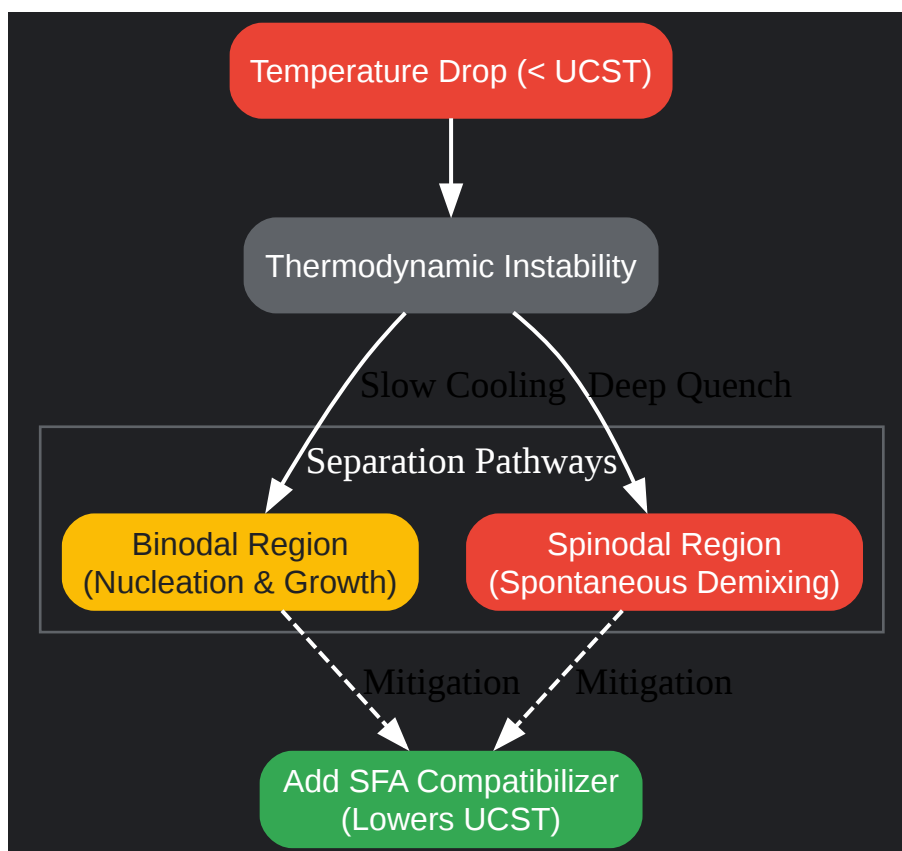

[Click to download full resolution via product page](#)

Figure 2: Logical flow of temperature-induced phase separation and mitigation via SFA addition.

FAQ: Rapid Fire Troubleshooting

Q: Can I use standard phospholipids (Egg Yolk Lecithin) for FC emulsions? A: Yes, but only if you use a co-surfactant. Phospholipids alone form weak interfaces with FCs. Adding a mixed fluorocarbon-hydrocarbon amphiphile (like

) acts as a co-surfactant, anchoring the lipid tails to the FC droplet [1].[6]

Q: Why does my drug precipitate out of the fluorocarbon phase? A: Fluorocarbons are notoriously poor solvents for both lipophilic and hydrophilic drugs.

- Fix: Do not try to dissolve the drug directly in the FC. Use a Semi-Fluorinated Alkane as a co-solvent.[2][7] The drug dissolves in the hydrocarbon block of the SFA, while the fluorocarbon block keeps the SFA soluble in the bulk fluorocarbon [2].

Q: How do I measure if my stabilization is working? A: Do not rely on visual inspection. Use Sedimentation Field-Flow Fractionation (SdFFF) or Dynamic Light Scattering (DLS). If the particle size distribution shifts to the right (larger sizes) over 48 hours, your Ostwald ripening inhibition is insufficient [4].

References

- Krafft, M. P., et al. (2004). Cosurfactant effect of a semifluorinated alkane at a fluorocarbon/water interface: impact on the stabilization of fluorocarbon-in-water emulsions.
- Broniatowski, M., & Dynarowicz-Łątka, P. (2008).[3][8] Semifluorinated alkanes—Primitive surfactants of fascinating properties. *Advances in Colloid and Interface Science*.
- Kabalnov, A., & Shchukin, E. D. (1992).[9] Ostwald ripening theory: applications to fluorocarbon emulsion stability. *Advances in Colloid and Interface Science*.
- Weers, J. G., et al. (1994).[9] Analysis of Ostwald ripening in fluorocarbon emulsions by sedimentation field-flow fractionation. *Artificial Cells, Blood Substitutes, and Biotechnology*.
- Marrucho, I. M., et al. (2006). Liquid-liquid equilibrium of (perfluoroalkane + alkane) binary mixtures. *Fluid Phase Equilibria*.

Need Custom Synthesis?

BenchChem offers custom synthesis for rare earth carbides and specific isotopic labeling.

Email: info@benchchem.com or [Request Quote Online](#).

Sources

- [1. Semifluorinated alkanes--primitive surfactants of fascinating properties - PubMed \[pubmed.ncbi.nlm.nih.gov\]](#)
- [2. pubs.acs.org \[pubs.acs.org\]](#)
- [3. researchgate.net \[researchgate.net\]](#)
- [4. Fluorocarbon emulsions--the stability issue - PubMed \[pubmed.ncbi.nlm.nih.gov\]](#)

- 5. Upper critical solution temperature of perfluoro-n-alkane and n-alkane mixtures - Transactions of the Faraday Society (RSC Publishing) [pubs.rsc.org]
- 6. Cosurfactant effect of a semifluorinated alkane at a fluorocarbon/water interface: impact on the stabilization of fluorocarbon-in-water emulsions - PubMed [pubmed.ncbi.nlm.nih.gov]
- 7. Sci-Hub: Adsorption and Aggregation of Semifluorinated Alkanes in Binary and Ternary Mixtures with Hydrocarbon and Fluorocarbon Solvents [sci-hub.red]
- 8. Semifluorinated alkanes — Primitive surfactants of fascinating properties [ouci.dntb.gov.ua]
- 9. [semanticscholar.org](https://www.semanticscholar.org) [[semanticscholar.org](https://www.semanticscholar.org)]
- To cite this document: BenchChem. [Technical Support Center: Fluorinated & Hydrocarbon Blend Stabilization]. BenchChem, [2026]. [Online PDF]. Available at: [<https://www.benchchem.com/product/b590017/docs#technical-support-center-fluorinated-hydrocarbon-blend-stabilization>]

Disclaimer & Data Validity:

The information provided in this document is for Research Use Only (RUO) and is strictly not intended for diagnostic or therapeutic procedures. While BenchChem strives to provide accurate protocols, we make no warranties, express or implied, regarding the fitness of this product for every specific experimental setup.

Technical Support: The protocols provided are for reference purposes. Unsure if this reagent suits your experiment?

Need Industrial/Bulk Grade? [Request Custom Synthesis Quote](#)

BenchChem

Our mission is to be the trusted global source of essential and advanced chemicals, empowering scientists and researchers to drive progress in science and industry.

Contact

Address: 3281 E Guasti Rd

Ontario, CA 91761, United States

Phone: (601) 213-4426

Email: info@benchchem.com

Contact our Ph.D. Support Team for a compatibility check