

Optimizing palladium catalyst for Alloc group removal

Author: BenchChem Technical Support Team. **Date:** May 2026

Compound of Interest

Compound Name: *Fmoc-Arg(Alloc)2-OH*

CAS No.: 148893-34-9

Cat. No.: B589151

[Get Quote](#)

Welcome to the Technical Support Center for Optimizing Palladium Catalysts for Allyloxycarbonyl (Alloc) Group Removal. This guide provides researchers, scientists, and drug development professionals with comprehensive troubleshooting advice, frequently asked questions, and detailed protocols to enhance the efficiency and success of your experiments.

Troubleshooting Guide

This section addresses specific issues that may arise during the palladium-catalyzed removal of the Alloc protecting group.

Question: Why is my Alloc deprotection incomplete?

Answer: Incomplete deprotection can be attributed to several factors:

- **Catalyst Inactivity:** The most commonly used catalyst, Tetrakis(triphenylphosphine)palladium(0) ($\text{Pd}(\text{PPh}_3)_4$), is sensitive to oxidation and can lose activity if handled in the presence of air.^{[1][2]} Consider using a more air-stable catalyst such as Dichlorobis(triphenylphosphine)palladium(II) ($\text{Pd}(\text{PPh}_3)_2\text{Cl}_2$).^[1]

- **Insufficient Scavenger:** The scavenger is crucial for trapping the allyl cation and regenerating the Pd(0) catalyst. An inadequate amount of scavenger will lead to a stalled reaction. It is recommended to use a significant excess of the scavenger.
- **Substrate Steric Hindrance:** Sterically hindered amines may react more slowly. In such cases, extending the reaction time or slightly increasing the temperature may be necessary.
- **Reaction Time:** The kinetics of deprotection can vary, especially between primary and secondary amines.[3] Ensure sufficient reaction time for complete removal. Monitoring the reaction progress by LC-MS is advisable.[4]

Question: I am observing a significant amount of N-allylated byproduct. How can I prevent this?

Answer: The formation of N-allylated byproducts is a common side reaction where the liberated allyl group re-alkylates the deprotected amine. To mitigate this:

- **Choice of Scavenger:** The selection of an appropriate scavenger is critical. While phenylsilane (PhSiH_3) and morpholine are often used, they can be less effective at preventing N-allylation.[3] The dimethylamine-borane complex ($\text{Me}_2\text{NH}\cdot\text{BH}_3$) has been shown to be a superior scavenger, leading to quantitative removal of the Alloc group without back alkylation.[3][5]
- **Scavenger Concentration:** Using a high concentration of a highly effective scavenger ensures that the allyl cation is trapped before it can react with the deprotected amine.

Question: My palladium catalyst appears to be decomposing (turning black). What should I do?

Answer: The formation of palladium black indicates the decomposition of the Pd(0) complex.

- **Use an Air-Stable Catalyst:** As mentioned, $\text{Pd}(\text{PPh}_3)_4$ is prone to oxidation. Switching to an air-stable catalyst like $\text{Pd}(\text{PPh}_3)_2\text{Cl}_2$ can prevent this issue, allowing for "open-flask" protocols.[1]
- **Degas Solvents:** If using an air-sensitive catalyst, ensure that all solvents are thoroughly degassed before use to remove dissolved oxygen.

- Inert Atmosphere: Conduct the reaction under an inert atmosphere of nitrogen or argon to protect the catalyst from oxygen.[6]

Question: How do I choose the right solvent for my Alloc deprotection?

Answer: Dichloromethane (DCM) and N,N-dimethylformamide (DMF) are commonly used solvents for Alloc deprotection.[2] However, greener solvent alternatives have also been explored.[2] The choice of solvent can influence the reaction rate, so it may be a parameter to screen when optimizing your reaction.[2]

Frequently Asked Questions (FAQs)

Q1: What is the general mechanism of palladium-catalyzed Alloc removal?

A1: The deprotection proceeds via the Tsuji-Trost reaction. The Pd(0) catalyst coordinates to the allyl group of the Alloc-protected amine. This is followed by oxidative addition to form a π -allyl palladium(II) complex, releasing the carbamate, which then decarboxylates to yield the free amine. A scavenger is required to react with the π -allyl complex, regenerating the Pd(0) catalyst for the next cycle.[7][8]

Q2: Can I use microwave heating to speed up the deprotection?

A2: Yes, microwave heating has been successfully used to accelerate Alloc deprotection. Gentle heating to around 40°C can significantly reduce reaction times, even with air-sensitive catalysts under atmospheric conditions.[9]

Q3: How can I remove residual palladium from my product after the reaction?

A3: Residual palladium can be removed by washing the resin with a solution of a chelating agent, such as 5 mM sodium diethyldithiocarbamate in DMF.[6] Filtering the reaction mixture through Celite can also help in removing palladium residues.[10]

Q4: Is the Alloc group compatible with other common protecting groups?

A4: Yes, the Alloc group is a key component of orthogonal protecting group strategies in peptide synthesis. It is stable to the acidic conditions used to remove Boc groups and the basic conditions used for Fmoc group removal, making it highly versatile.[7][11]

Quantitative Data Summary

The following tables provide a summary of common reagents and conditions for Alloc deprotection to aid in the selection of optimal parameters.

Table 1: Comparison of Common Allyl Scavengers

Scavenger	Typical Equivalents	Key Advantages	Potential Issues
Phenylsilane (PhSiH ₃)	15 - 20	Effective hydride donor.[6][8]	Can be less effective at preventing N-allylation compared to other scavengers.[3]
Dimethylamine-borane (Me ₂ NH·BH ₃)	40	Highly effective at preventing N-allylated byproducts.[3][5]	Requires a higher number of equivalents.
Morpholine	-	Nucleophilic scavenger.[8]	Can be inferior to other scavengers in preventing side reactions.[3]
Meldrum's acid / TES-H / DIPEA	3 (of each)	Used in a novel, efficient protocol with air-stable catalysts.[4]	A multi-component system that requires careful preparation.

Table 2: Comparison of Palladium Catalysts

Catalyst	Typical Equivalents	Stability	Notes
$\text{Pd}(\text{PPh}_3)_4$	0.2 - 0.25	Air-sensitive.[2][9]	The most common but requires an inert atmosphere for best results.
$\text{Pd}(\text{PPh}_3)_2\text{Cl}_2$	0.2	Air-stable.[1]	Enables "open-flask" procedures, simplifying the experimental setup.

Experimental Protocols

Protocol 1: Standard Alloc Deprotection on Solid-Phase Support

This protocol is suitable for the deprotection of an Alloc-protected amine on a resin-bound peptide.

- Resin Preparation: Swell the Alloc-protected peptidyl resin in dichloromethane (DCM) in a reaction vessel.
- Reagent Solution Preparation: Under an inert atmosphere (e.g., argon or nitrogen), prepare a solution of $\text{Pd}(\text{PPh}_3)_4$ (0.2 equivalents) and phenylsilane (20 equivalents) in DCM.[6]
- Deprotection Reaction: Add the reagent solution to the resin. Agitate the mixture at room temperature for 20-40 minutes.[6][11]
- Repeat Deprotection: Drain the reaction vessel and repeat the deprotection step with a fresh solution of the catalyst and scavenger to ensure complete removal of the Alloc group.[6][7]
- Washing: After the final deprotection step, thoroughly wash the resin with DCM, followed by methanol, and then again with DCM.[7]
- Palladium Removal (Optional): To remove residual palladium, wash the resin with a solution of 5 mM sodium diethyldithiocarbamate in DMF.[6]

Protocol 2: Open-Flask Alloc Deprotection using an Air-Stable Catalyst

This protocol utilizes an air-stable palladium catalyst, simplifying the procedure by eliminating the need for a strict inert atmosphere.

- Resin Preparation: Swell the Alloc-protected peptidyl resin in a suitable solvent like DMF in a standard reaction vessel.
- Scavenger Solution Preparation: Prepare a scavenger solution. For example, a solution of Meldrum's acid (3 equivalents), triethylsilane (TES-H, 3 equivalents), and diisopropylethylamine (DIPEA, 3 equivalents) in DMF.[4]
- Catalyst Solution Preparation: Prepare a solution of the air-stable catalyst, Pd(PPh₃)₂Cl₂ (0.2 equivalents), in DMF.[4]
- Deprotection Reaction: Add the scavenger solution to the resin, followed by the catalyst solution. Agitate the mixture at room temperature. Monitor the reaction by LC-MS until completion (typically 10-20 minutes).[4]
- Washing: Once the reaction is complete, drain the reaction vessel and wash the resin thoroughly with DMF, followed by DCM.

Visualized Workflows and Mechanisms

The following diagrams, generated using Graphviz, illustrate key processes in Alloc deprotection.

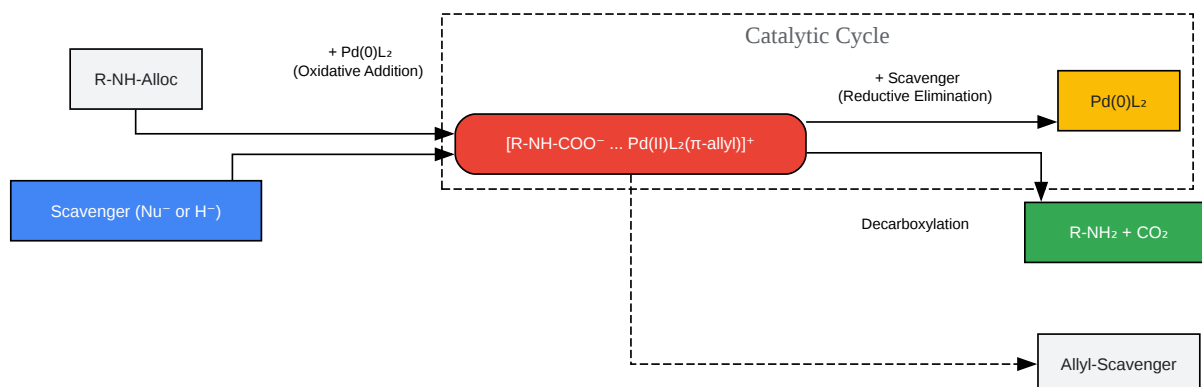

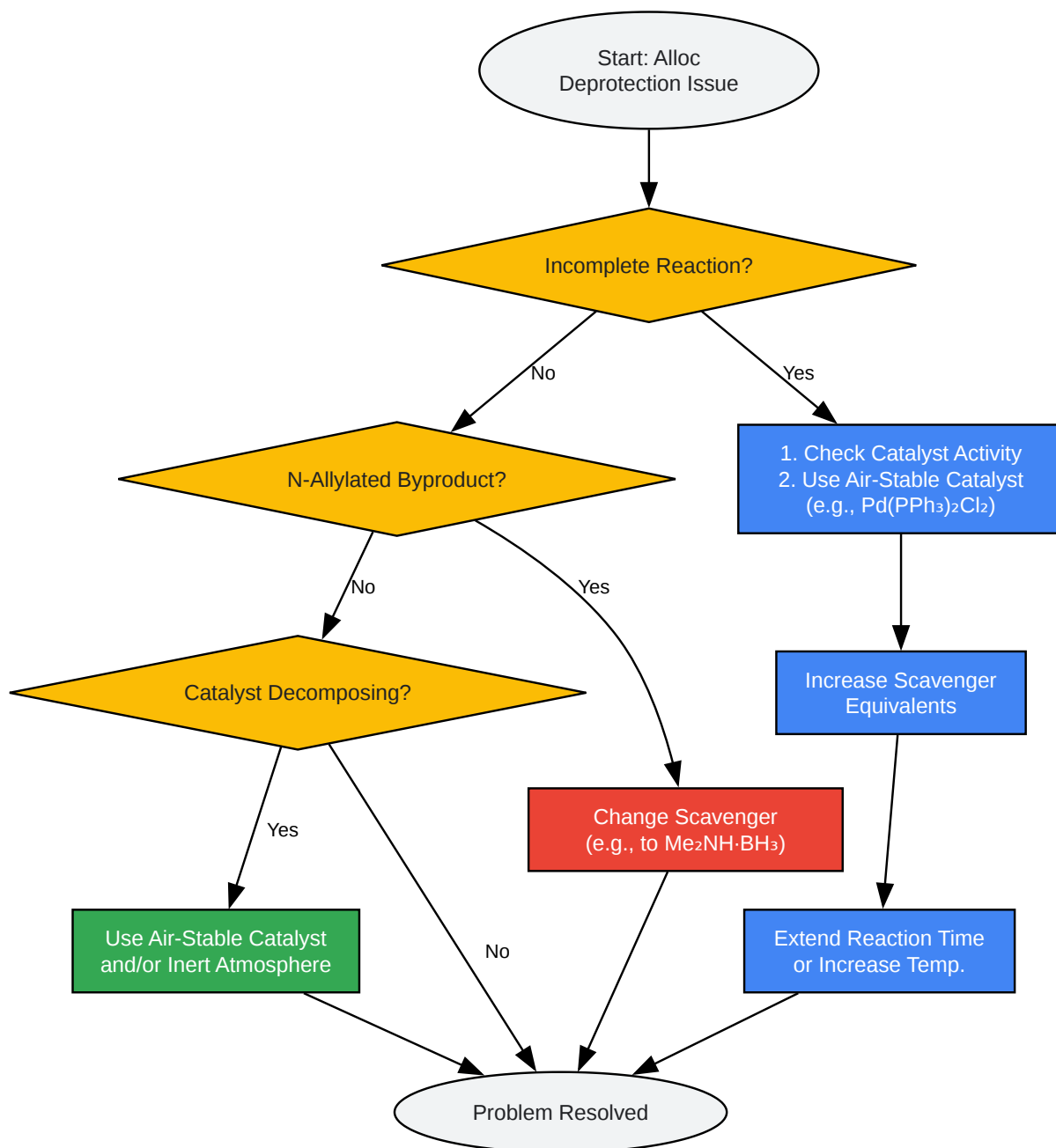

[Click to download full resolution via product page](#)

Need Custom Synthesis?

BenchChem offers custom synthesis for rare earth carbides and specific isotopic labeling.

Email: info@benchchem.com or [Request Quote Online](#).

References

- [1. pubs.acs.org](https://pubs.acs.org) [pubs.acs.org]
- [2. pubs.acs.org](https://pubs.acs.org) [pubs.acs.org]
- [3. researchgate.net](https://researchgate.net) [researchgate.net]
- [4. pubs.acs.org](https://pubs.acs.org) [pubs.acs.org]
- [5. researchgate.net](https://researchgate.net) [researchgate.net]
- [6. Engineering an affinity-enhanced peptide through optimization of cyclization chemistry - PMC](https://pubmed.ncbi.nlm.nih.gov/) [[pmc.ncbi.nlm.nih.gov](https://pubmed.ncbi.nlm.nih.gov/)]
- [7. bpb-us-w2.wpmucdn.com](https://www.bpb-us-w2.wpmucdn.com) [[bpb-us-w2.wpmucdn.com](https://www.bpb-us-w2.wpmucdn.com)]
- [8. total-synthesis.com](https://www.total-synthesis.com) [[total-synthesis.com](https://www.total-synthesis.com)]
- [9. biotage.com](https://www.biotage.com) [[biotage.com](https://www.biotage.com)]
- [10. researchgate.net](https://researchgate.net) [researchgate.net]
- [11. benchchem.com](https://www.benchchem.com) [[benchchem.com](https://www.benchchem.com)]
- To cite this document: BenchChem. [Optimizing palladium catalyst for Alloc group removal]. BenchChem, [2026]. [Online PDF]. Available at: [<https://www.benchchem.com/product/b589151/docs#optimizing-palladium-catalyst-for-alloc-group-removal>]

Disclaimer & Data Validity:

The information provided in this document is for Research Use Only (RUO) and is strictly not intended for diagnostic or therapeutic procedures. While BenchChem strives to provide accurate protocols, we make no warranties, express or implied, regarding the fitness of this product for every specific experimental setup.

Technical Support: The protocols provided are for reference purposes. Unsure if this reagent suits your experiment?

Need Industrial/Bulk Grade? [Request Custom Synthesis Quote](#)

BenchChem

Our mission is to be the trusted global source of essential and advanced chemicals, empowering scientists and researchers to drive progress in science and industry.

Contact

Address: 3281 E Guasti Rd

Ontario, CA 91761, United States

Phone: (601) 213-4426

Email: info@benchchem.com

[Contact our Ph.D. Support Team for a compatibility check](#)