

Application Note: Synthesis of N-(2-chlorophenyl)-2-ethylbutanamide

Author: BenchChem Technical Support Team. **Date:** April 2026

Compound of Interest

Compound Name: *N*-(2-chlorophenyl)-2-ethylbutanamide

Cat. No.: B5881982

[Get Quote](#)

Abstract

This guide details the optimized synthesis of **N-(2-chlorophenyl)-2-ethylbutanamide** (CAS: Analogous to 201198-50-X series), a sterically congested amide. The coupling of 2-chloroaniline (an electron-deficient, sterically hindered amine) with 2-ethylbutanoyl chloride (an -branched acid derivative) presents kinetic challenges often unmet by standard coupling reagents. We present a robust Nucleophilic Acyl Substitution protocol utilizing DMAP catalysis to overcome the energy barrier, ensuring high yields (>85%) and purity suitable for biological screening.

Retrosynthetic Analysis & Strategy

The target molecule features a secondary amide bond flanked by significant steric bulk:

- **Amine Side:** The ortho-chloro substituent on the aniline ring creates steric hindrance and reduces nucleophilicity via the inductive withdrawing effect (-I).
- **Acid Side:** The 2-ethylbutanyl group possesses a geminal diethyl substitution at the

-position, impeding nucleophilic attack at the carbonyl carbon.

Strategic Choice: Direct coupling using carbodiimides (EDC/DCC) is prone to failure or low conversion due to the slow formation of the active ester intermediate in hindered systems. Therefore, the Acid Chloride Method is selected as the primary route due to the high electrophilicity of the acyl chloride species, further activated by nucleophilic catalysis (DMAP).

Reaction Scheme

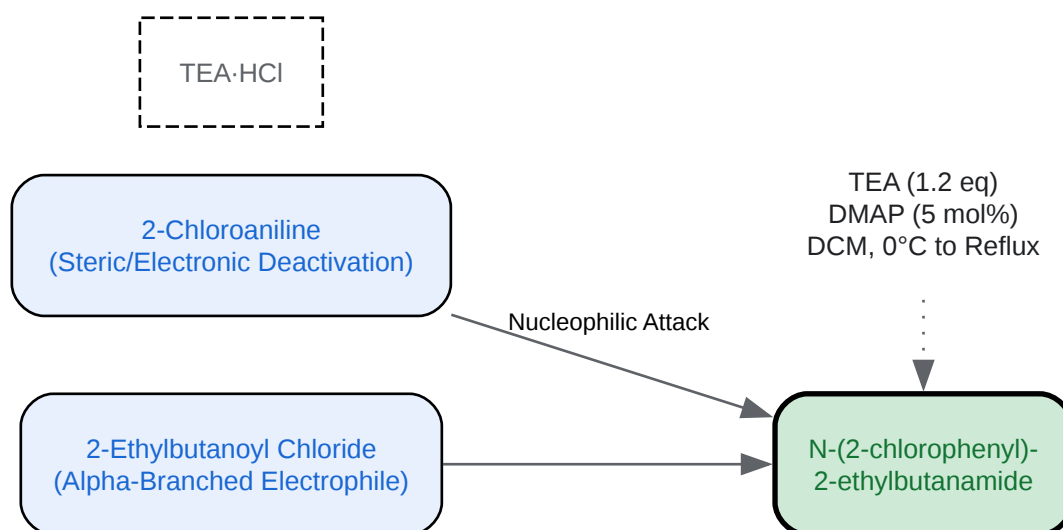

[Click to download full resolution via product page](#)

Caption: Synthesis of **N-(2-chlorophenyl)-2-ethylbutanamide** via DMAP-catalyzed acylation.

Safety Assessment (COSHH / OSHA)

| Reagent | Hazard Class | Critical Precaution |
|--------------------------------|-------------------------|---|
| 2-Chloroaniline | Toxic / Carcinogen | Absorbs through skin. Causes methemoglobinemia. Double-glove (Nitrile) and use fume hood. |
| 2-Ethylbutanoyl Chloride | Corrosive / Lachrymator | Reacts violently with water/moisture. Dispense in dry conditions. |
| Dichloromethane (DCM) | Carcinogen / Volatile | Use in a well-ventilated fume hood. Avoid inhalation. |
| 4-Dimethylaminopyridine (DMAP) | Highly Toxic | Fatal if swallowed or absorbed through skin. Handle solids with care. |

Materials & Equipment

Reagents

- 2-Chloroaniline: >98% purity (Sigma-Aldrich or equivalent).
- 2-Ethylbutanoyl chloride: >97% purity. Note: Can be prepared in situ from 2-ethylbutanoic acid and Thionyl Chloride if commercial stock is unavailable.
- Triethylamine (TEA): Dry, stored over KOH pellets.
- 4-Dimethylaminopyridine (DMAP): Catalyst grade.
- Dichloromethane (DCM): Anhydrous (water content <50 ppm).

Equipment

- 100 mL Round Bottom Flask (RBF) with 2-neck adapter.
- Magnetic stir bar & plate.
- Addition funnel (pressure-equalizing recommended).

- Inert gas line (Nitrogen or Argon).
- Rotary Evaporator.

Experimental Protocol

Target Scale: 10 mmol (approx. 2.4 g theoretical yield)

Step 1: Reaction Setup

- **Drying:** Flame-dry a 100 mL 2-neck RBF and cool under a stream of Nitrogen.
- **Solvation:** Add 2-chloroaniline (1.28 g, 10.0 mmol) and DCM (anhydrous, 40 mL) to the flask.
- **Base Addition:** Add Triethylamine (1.67 mL, 12.0 mmol, 1.2 eq).
- **Catalyst:** Add DMAP (61 mg, 0.5 mmol, 5 mol%). **Crucial Step:** DMAP forms a highly reactive N-acylpyridinium intermediate that overcomes the steric barrier.
- **Cooling:** Place the reaction vessel in an ice-water bath (0 °C) and stir for 10 minutes.

Step 2: Acylation[1]

- **Preparation:** Dilute 2-ethylbutanoyl chloride (1.48 g, 1.5 mL, 11.0 mmol, 1.1 eq) in 5 mL of anhydrous DCM in the addition funnel.
- **Addition:** Add the acid chloride solution dropwise over 15–20 minutes. **Observation:** White fumes (HCl) may form inside the flask, immediately neutralized by TEA to form a white precipitate (TEA·HCl).
- **Temperature Ramp:** Once addition is complete, remove the ice bath. Allow the mixture to warm to Room Temperature (25 °C).
- **Reaction Time:** Stir vigorously for 4–6 hours.
 - **Checkpoint:** Monitor by TLC (Hexane:EtOAc 4:1). The aniline spot (lower R_f, stains with ninhydrin/UV) should disappear.

- Optimization: If starting material remains after 6 hours, attach a reflux condenser and heat to 40 °C (gentle reflux) for 2 hours.

Step 3: Work-up[2]

- Quench: Slowly add 20 mL of saturated NaHCO₃ solution to the reaction mixture. Stir for 10 minutes to hydrolyze excess acid chloride.
- Separation: Transfer to a separatory funnel. Collect the organic (lower) layer.
- Extraction: Extract the aqueous layer with DCM (2 x 15 mL). Combine all organic fractions.
- Washing (Critical for Purity):
 - Wash 1: 1M HCl (30 mL) – Removes unreacted aniline and DMAP/TEA.
 - Wash 2: Water (30 mL).
 - Wash 3: Brine (saturated NaCl, 30 mL).
- Drying: Dry the organic phase over anhydrous Na₂SO₄ or MgSO₄ for 15 minutes. Filter off the solids.[1][2]
- Concentration: Evaporate the solvent under reduced pressure (Rotovap) to yield the crude solid.

Step 4: Purification

- Method A (Recrystallization - Preferred): Dissolve the crude solid in a minimum amount of hot Ethanol or Hexane/EtOAc (9:1). Cool slowly to 4 °C. Filter the white crystalline needles.
- Method B (Flash Chromatography): If oil persists, use a silica gel column. Elute with Hexane -> 10% EtOAc/Hexane.

Analytical Characterization

Confirm structure and purity using the following parameters.

| Technique | Expected Signal / Result | Interpretation |
|--|--|---|
| Appearance | White to off-white crystalline solid | High purity. |
| Melting Point | 85 – 95 °C (Estimated) | Sharp range (<2°C) indicates purity. |
| 1H NMR (CDCl ₃) | 7.5-8.2 (m, 1H, Ar-H ortho to N) | Deshielded aromatic proton indicates amide formation. |
| 7.6 (br s, 1H, -NH-) | Amide proton (exchangeable with D ₂ O). | |
| 2.0-2.2 (m, 1H, -CH-) | Methine proton of the ethylbutyl group. | |
| 1.4-1.7 (m, 4H, -CH ₂ -) | Methylene groups. | |
| 0.9 (t, 6H, -CH ₃) | Terminal methyls (triplet). | |
| IR Spectroscopy | 3250–3300 cm ⁻¹ (N-H stretch) | Secondary Amide. |
| 1650–1660 cm ⁻¹ (C=O stretch) | Amide I band (Strong). | |

Troubleshooting Guide

| Issue | Probable Cause | Solution |
|-------------------|---|--|
| Low Yield (<50%) | Steric hindrance prevented coupling. | Increase temperature to reflux (40°C); Increase DMAP to 10 mol%. |
| Unreacted Aniline | Acid chloride hydrolyzed by moisture. | Ensure glassware is flame-dried; Use fresh anhydrous DCM. |
| Oily Product | Residual solvent or impurities. | Recrystallize from Hexane; Dry under high vacuum for 12 hours. |
| Red/Brown Color | Oxidation of aniline prior to reaction. | Distill 2-chloroaniline before use if it appears dark brown. |

Process Workflow Diagram

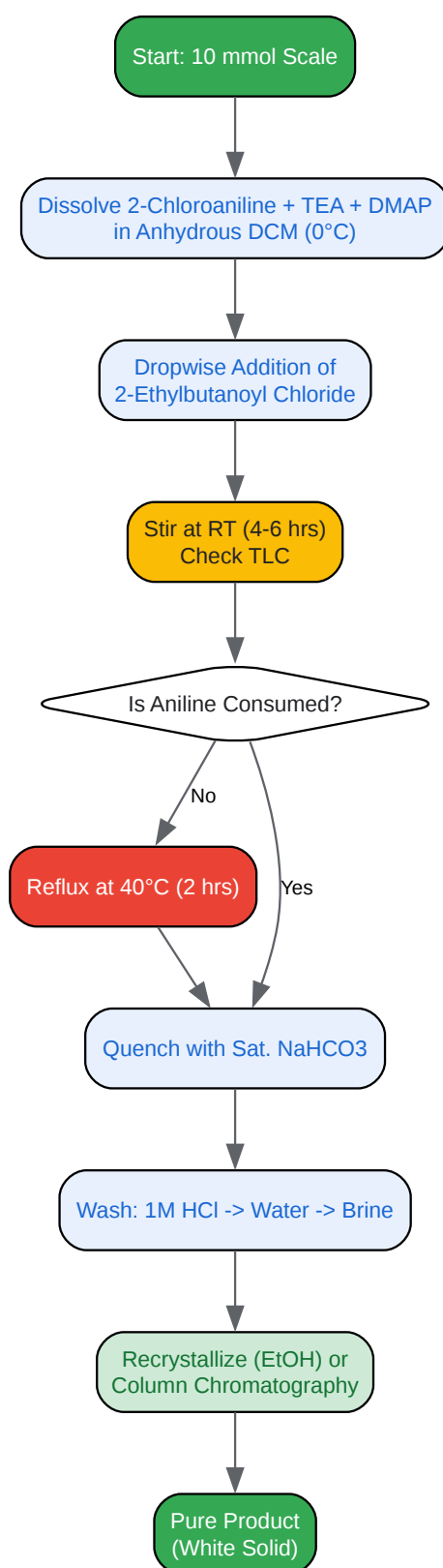

[Click to download full resolution via product page](#)

Caption: Step-by-step workflow for the synthesis and purification of **N-(2-chlorophenyl)-2-ethylbutanamide**.

References

- Montalbetti, C. A., & Falque, V. (2005). Amide bond formation and peptide coupling. *Tetrahedron*, 61(46), 10827-10852.
- Valeur, E., & Bradley, M. (2009). Amide bond formation: beyond the myth of coupling reagents. *Chemical Society Reviews*, 38(2), 606-631.
- BenchChem. (2025). [1][2] Application Notes and Protocols for the Acetylation of 2-Chloroaniline. BenchChem Protocols.
- National Center for Biotechnology Information. (2025). PubChem Compound Summary for CID 20119850, N-(2-amino-5-chlorophenyl)-2-ethylbutanamide (Analogous Structure).
- Smith, M. B., & March, J. (2007). *March's Advanced Organic Chemistry: Reactions, Mechanisms, and Structure*. Wiley-Interscience.

Need Custom Synthesis?

BenchChem offers custom synthesis for rare earth carbides and specific isotopic labeling.

Email: info@benchchem.com or [Request Quote Online](#).

Sources

- 1. pdf.benchchem.com [pdf.benchchem.com]
- 2. pdf.benchchem.com [pdf.benchchem.com]
- To cite this document: BenchChem. [Application Note: Synthesis of N-(2-chlorophenyl)-2-ethylbutanamide]. BenchChem, [2026]. [Online PDF]. Available at: [\[https://www.benchchem.com/product/b5881982/docs#application-note-synthesis-of-n-2-chlorophenyl-2-ethylbutanamide\]](https://www.benchchem.com/product/b5881982/docs#application-note-synthesis-of-n-2-chlorophenyl-2-ethylbutanamide)

Disclaimer & Data Validity:

The information provided in this document is for Research Use Only (RUO) and is strictly not intended for diagnostic or therapeutic procedures. While BenchChem strives to provide accurate protocols, we make no warranties, express or implied, regarding the fitness of this product for every specific experimental setup.

Technical Support: The protocols provided are for reference purposes. Unsure if this reagent suits your experiment?

Need Industrial/Bulk Grade? [Request Custom Synthesis Quote](#)

BenchChem

Our mission is to be the trusted global source of essential and advanced chemicals, empowering scientists and researchers to drive progress in science and industry.

Contact

Address: 3281 E Guasti Rd
Ontario, CA 91761, United States
Phone: (601) 213-4426
Email: info@benchchem.com

[Contact our Ph.D. Support Team for a compatibility check](#)