

Technical Support Center: Prasugrel & Metabolite MS/MS Bioanalysis

Author: BenchChem Technical Support Team. **Date:** May 2026

Compound of Interest

Compound Name: *m-Fluoro Prasugrel-d4 Hydrochloride*
CAS No.: *1794828-80-0*
Cat. No.: *B588189*

[Get Quote](#)

Role: Senior Application Scientist Topic: Eliminating Isotopic & Chemical Interference in Prasugrel MS Spectra Status: Operational

Introduction: The Prasugrel Challenge

Welcome to the technical support hub for Prasugrel bioanalysis. As researchers, you likely face a specific set of spectral challenges when analyzing Prasugrel (parent) and its active metabolite (R-138727).

While "isotopic interference" often refers to the crosstalk between an analyte and its Internal Standard (IS), Prasugrel analysis presents a triad of interference risks that can compromise data integrity:

- True Isotopic Crosstalk: Signal bleed between the analyte and its deuterated internal standard (Prasugrel-D5).
- Chemical Instability (The "Disappearing" Signal): The rapid hydrolysis of the active metabolite's thiol group, leading to variable signal intensity.

- Isobaric Interference (In-Source Fragmentation): Labile metabolites (e.g., glucuronides) breaking down in the ion source to mimic the parent drug or active metabolite.

This guide provides validated protocols to eliminate these interferences.

Module 1: Eliminating Isotopic Crosstalk (Analyte vs. IS)

The Mechanism

In LC-MS/MS, we typically use Prasugrel-D5 as the Internal Standard (IS). Two types of interference occur here:

- Contribution to IS (M+5): At high Prasugrel concentrations, the naturally occurring and isotopes of the analyte can create a signal in the IS channel (373 and 378).
- Contribution to Analyte (D0 Impurity): The synthesized Prasugrel-D5 standard may contain traces of unlabeled Prasugrel (D0), which creates a false positive signal in the analyte channel.

Diagnostic Workflow

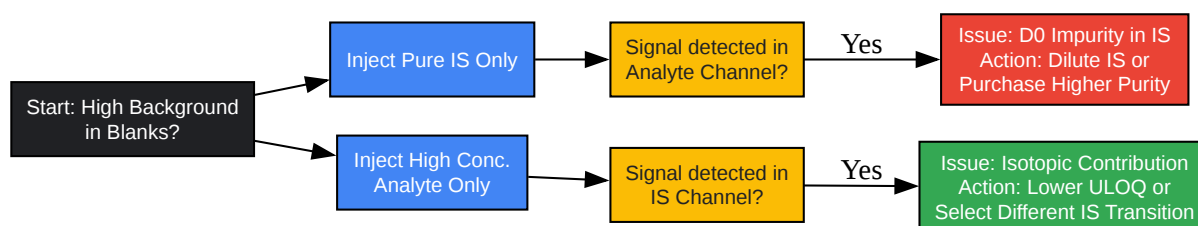

[Click to download full resolution via product page](#)

Figure 1: Decision tree for diagnosing isotopic crosstalk between Prasugrel and Prasugrel-D5.

Optimization Protocol

- IS Concentration Tuning: Do not arbitrarily set the IS concentration. It must be high enough to drown out the M+5 contribution from the analyte but low enough that its D0 impurity does not affect the Lower Limit of Quantitation (LLOQ).
 - Recommendation: Set IS concentration to produce a signal equivalent to 50% of the analyte signal at the geometric mean of the calibration curve.
- Mass Resolution: If using Triple Quadrupole (QqQ), ensure unit resolution (0.7 FWHM) on both Q1 and Q3. Widening windows to increase sensitivity will increase isotopic interference.

Module 2: The Active Metabolite (R-138727) Stabilization

The most significant "interference" in Prasugrel analysis is actually chemical degradation. The active metabolite (R-138727) contains a reactive thiol (-SH) group.^[1] Without stabilization, it oxidizes into disulfides or reacts with plasma proteins, causing erratic MS spectra and false-negative results.

You cannot analyze R-138727 directly. You must derivatize it.^{[2][3]}

Derivatization Protocol (MPB Method)

The industry standard involves trapping the thiol with 2-bromo-3'-methoxyacetophenone (MPB) immediately upon blood collection.

Reagents:

- MPB Solution: 0.5 M MPB in Acetonitrile.
- Acidification: 1M HCl (to prevent acyl migration/hydrolysis of parent).

Step-by-Step Workflow:

- Collection: Draw blood into vacutainers containing EDTA.

- Immediate Derivatization: Within 30 seconds, add MPB solution to the blood (Ratio: 10 µL MPB per 1 mL blood).
- Acidification: Add dilute HCl to lower pH (stabilizes the parent Prasugrel).
- Processing: Centrifuge to harvest plasma.
- Extraction: Perform Liquid-Liquid Extraction (LLE) or Solid Phase Extraction (SPE).

Resulting MS Transition: The derivatization shifts the precursor mass, moving it away from many endogenous interferences.

Analyte	Precursor Ion ()	Product Ion ()	Comment
Prasugrel (Parent)	374.1	262.1	Protonated molecule
R-138727 (Active)	Unstable - Do Not Use	N/A	Rapidly degrades
R-138727-MPB (Derivatized)	498.2	206.1	Stable Thioether derivative
IS (Prasugrel-D5)	379.1	267.1	For Parent
IS (R-138727-D4-MPB)	502.2	210.1	For Active Metabolite

Table 1: Optimized MRM transitions for Prasugrel and its derivatized metabolite [1][2].

Module 3: Eliminating "Ghost" Signals (In-Source Fragmentation)

A common spectral artifact arises when inactive metabolites (like Prasugrel Thiolactone or Glucuronide conjugates) co-elute with your analyte. In the high-energy environment of the ESI source, these metabolites can lose their conjugate group, reverting to the mass of the parent or active metabolite.

Symptom: You see a peak in the Prasugrel channel at a retention time slightly different from the authentic standard.

Chromatographic Solution

You must chromatographically resolve the metabolites from the parent.

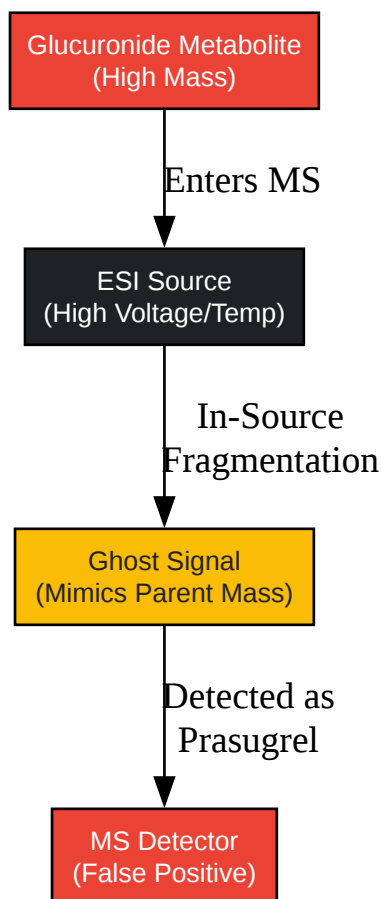

[Click to download full resolution via product page](#)

Figure 2: Mechanism of In-Source Fragmentation Interference.

Protocol:

- Monitor Metabolites: During method development, include MRM transitions for the Thiolactone (R-95913, 332) and Glucuronides.

- Column Selection: Use a high-strength silica (HSS) or C18 column with high carbon load to separate polar glucuronides from the parent.
- Gradient Optimization: Ensure the parent Prasugrel elutes after the solvent front but is fully resolved from the early-eluting polar metabolites.

Frequently Asked Questions (FAQs)

Q: Can I use Clopidogrel as an Internal Standard for Prasugrel? A: No. While structurally similar (thienopyridines), they have different retention times and matrix effects. Using Clopidogrel will not accurately compensate for the specific ion suppression experienced by Prasugrel or its MPB-derivative. Always use Prasugrel-D5 or R-138727-D4 [3].

Q: My Prasugrel-D5 IS signal is varying between samples. Why? A: This is likely a Matrix Effect caused by phospholipids.

- Check: Monitor phospholipid transitions (

184

184).

- Fix: Switch from Protein Precipitation (PPT) to Solid Phase Extraction (SPE) or Phospholipid Removal Plates to clean the sample.

Q: Why do I see two peaks for the Active Metabolite (R-138727)? A: The active metabolite contains chiral centers. The MPB derivatization creates diastereomers (RS and SS forms).

- Action: You should integrate both peaks as the total active metabolite, or validate the method to quantify them separately if chiral separation is intended [2].

References

- Farid, N. A., et al. (2010). Metabolism and disposition of the thienopyridine antiplatelet agent prasugrel in humans.[2][4][5][6][7] Drug Metabolism and Disposition.[2][5][7] [Link](#)
- Kakarla, P., et al. (2016).[3][8] Analysis of prasugrel active metabolite R-138727 in human plasma: a sensitive, highly selective and fast LC-MS/MS method.[2][3][8] Journal of

Chromatography B. [Link](#)[8]

- Ni, L., et al. (2011). Simultaneous determination of prasugrel and its active metabolite R-138727 in human plasma by LC-MS/MS.[2][3][4][8] Journal of Pharmaceutical and Biomedical Analysis. [Link](#)

Need Custom Synthesis?

BenchChem offers custom synthesis for rare earth carbides and specific isotopic labeling.

Email: info@benchchem.com or [Request Quote Online](#).

Sources

- 1. Biotransformation of prasugrel, a novel thienopyridine antiplatelet agent, to the pharmacologically active metabolite - PubMed [pubmed.ncbi.nlm.nih.gov]
- 2. researchgate.net [researchgate.net]
- 3. au.edu.sy [au.edu.sy]
- 4. pdf.benchchem.com [pdf.benchchem.com]
- 5. Prasugrel for the treatment of patients with acute coronary syndrome - PMC [pmc.ncbi.nlm.nih.gov]
- 6. Prasugrel Intermediate Metabolite Modulates Platelet Inhibition by Negatively Interfering With an Active Metabolite: An Ex Vivo, In Vitro, and In Silico Study - PMC [pmc.ncbi.nlm.nih.gov]
- 7. Pharmacokinetics and pharmacodynamics of prasugrel, a thienopyridine P2Y12 inhibitor - PubMed [pubmed.ncbi.nlm.nih.gov]
- 8. Analysis of prasugrel active metabolite R-138727 in human plasma: a sensitive, highly selective and fast LC-MS/MS method - PubMed [pubmed.ncbi.nlm.nih.gov]
- To cite this document: BenchChem. [Technical Support Center: Prasugrel & Metabolite MS/MS Bioanalysis]. BenchChem, [2026]. [Online PDF]. Available at: [<https://www.benchchem.com/product/b588189/docs#technical-support-center-prasugrel-metabolite-ms-ms-bioanalysis>]

Disclaimer & Data Validity:

The information provided in this document is for Research Use Only (RUO) and is strictly not intended for diagnostic or therapeutic procedures. While BenchChem strives to provide accurate protocols, we make no warranties, express or implied, regarding the fitness of this product for every specific experimental setup.

Technical Support: The protocols provided are for reference purposes. Unsure if this reagent suits your experiment?

Need Industrial/Bulk Grade? [Request Custom Synthesis Quote](#)

BenchChem

Our mission is to be the trusted global source of essential and advanced chemicals, empowering scientists and researchers to drive progress in science and industry.

Contact

Address: 3281 E Guasti Rd
Ontario, CA 91761, United States
Phone: (601) 213-4426
Email: info@benchchem.com

[Contact our Ph.D. Support Team for a compatibility check](#)