

Introduction: Navigating Electrophilic Substitution on a Substituted Pyrrole Core

Author: BenchChem Technical Support Team. **Date:** May 2026

Compound of Interest

Compound Name:	1-Acetyl-5-methyl-1H-pyrrole-2-carbaldehyde
CAS No.:	144147-06-8
Cat. No.:	B588716

[Get Quote](#)

The pyrrole ring is a foundational scaffold in a multitude of biologically active compounds and pharmaceutical agents. Its electron-rich nature makes it highly susceptible to electrophilic aromatic substitution, a characteristic that is both a synthetic advantage and a challenge. The Friedel-Crafts acylation, a classic method for introducing a ketone moiety onto an aromatic ring, is a powerful tool for functionalizing these heterocycles.^{[1][2]} However, when the pyrrole ring is already substituted, as in the case of 5-methyl-1H-pyrrole-2-carbaldehyde, the reaction becomes a nuanced exercise in controlling regioselectivity.

This application note provides a comprehensive technical guide for researchers, medicinal chemists, and process development scientists on performing the Friedel-Crafts acylation of 5-methyl-1H-pyrrole-2-carbaldehyde. We will delve into the mechanistic principles governing the reaction's outcome, provide a detailed and robust experimental protocol, and offer practical troubleshooting advice. The substrate, 5-methyl-1H-pyrrole-2-carbaldehyde, presents a unique challenge due to the competing directing effects of an electron-donating methyl group and an electron-withdrawing formyl group. Understanding these influences is paramount to achieving the desired acylated product with high selectivity.

Mechanistic Rationale and Regiochemical Control

The Friedel-Crafts acylation proceeds via the generation of a highly electrophilic acylium ion from an acyl halide or anhydride, facilitated by a Lewis acid catalyst such as aluminum chloride (AlCl_3).^{[3][4]} This acylium ion then attacks the electron-rich pyrrole ring.

In an unsubstituted pyrrole, electrophilic attack occurs preferentially at the C2 (α) position due to the superior resonance stabilization of the resulting cationic intermediate (the Wheland intermediate).^[5] However, in 5-methyl-1H-pyrrole-2-carbaldehyde, the C2 and C5 positions are blocked. The substitution must therefore occur at either the C3 or C4 position. The outcome is dictated by the electronic properties of the existing substituents:

- 5-Methyl Group ($-\text{CH}_3$): An electron-donating, activating group that directs electrophilic attack to the adjacent (ortho) C4 position.
- 2-Carbaldehyde Group ($-\text{CHO}$): An electron-withdrawing, deactivating group that disfavors electrophilic attack at the adjacent (ortho) C3 position.

Consequently, the acylation is strongly directed to the C4 position, which is activated by the methyl group and less deactivated by the formyl group. The reaction is expected to yield 4-acyl-5-methyl-1H-pyrrole-2-carbaldehyde as the major product.

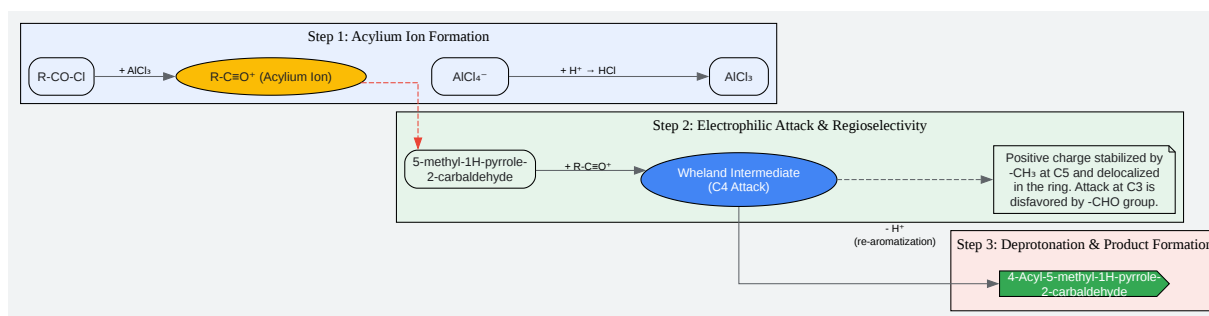

[Click to download full resolution via product page](#)

Caption: Mechanism of Friedel-Crafts acylation on 5-methyl-1H-pyrrole-2-carbaldehyde.

Detailed Experimental Protocol

This protocol describes the acetylation of 5-methyl-1H-pyrrole-2-carbaldehyde with acetyl chloride and aluminum chloride.

Safety Precautions:

- This procedure must be conducted in a well-ventilated fume hood.
- Anhydrous aluminum chloride is highly reactive with water and corrosive. Acetyl chloride is corrosive and a lachrymator. Handle with extreme care.
- Wear appropriate personal protective equipment (PPE), including safety goggles, a lab coat, and chemical-resistant gloves.
- The reaction is exothermic; strict temperature control is essential.

Materials and Reagents:

Reagent	M.W. (g/mol)	Amount (mmol)	Equivalents	Quantity
5-methyl-1H-pyrrole-2-carbaldehyde	123.14	10.0	1.0	1.23 g
Anhydrous Aluminum Chloride (AlCl ₃)	133.34	12.0	1.2	1.60 g
Acetyl Chloride (CH ₃ COCl)	78.50	11.0	1.1	0.86 g (0.78 mL)
Dichloromethane (DCM), anhydrous	-	-	-	50 mL
Hydrochloric Acid (HCl), 1M aqueous	-	-	-	30 mL
Saturated Sodium Bicarbonate (NaHCO ₃), aqueous	-	-	-	30 mL
Brine, saturated aqueous	-	-	-	30 mL
Anhydrous Magnesium Sulfate (MgSO ₄)	-	-	-	~2 g

Equipment:

- 100 mL three-neck round-bottom flask

- Magnetic stirrer and stir bar
- Dropping funnel
- Thermometer
- Condenser with a nitrogen/argon inlet
- Ice-water bath
- Separatory funnel
- Rotary evaporator
- Glassware for column chromatography

Procedure:

- **Reaction Setup:** Assemble the three-neck flask with a magnetic stir bar, thermometer, and dropping funnel. Attach the condenser with a nitrogen inlet to the central neck. Flame-dry the entire apparatus under a stream of inert gas (nitrogen or argon) and allow it to cool to room temperature.
- **Reagent Addition:** Add anhydrous aluminum chloride (1.60 g) to the reaction flask, followed by 20 mL of anhydrous dichloromethane. Begin stirring to create a suspension.
- **Cooling:** Cool the suspension to 0°C using an ice-water bath.
- **Acyl Chloride Addition:** Add acetyl chloride (0.78 mL) to the dropping funnel with 10 mL of anhydrous DCM. Add this solution dropwise to the stirred AlCl_3 suspension over 15 minutes, ensuring the internal temperature does not exceed 5°C.^[4] An orange-to-red complex should form.
- **Substrate Addition:** Dissolve the 5-methyl-1H-pyrrole-2-carbaldehyde (1.23 g) in 20 mL of anhydrous DCM and add it to the dropping funnel. Add the pyrrole solution dropwise to the reaction mixture over 30 minutes, maintaining the temperature at 0°C.

- **Reaction Monitoring:** After the addition is complete, allow the reaction to stir at 0°C for 1 hour, then let it warm to room temperature and stir for an additional 2-4 hours. Monitor the reaction progress by Thin Layer Chromatography (TLC) until the starting material is consumed.
- **Work-up (Quenching):** Cool the reaction mixture back to 0°C in an ice bath. Cautiously and slowly pour the mixture into a beaker containing 50 g of crushed ice and 15 mL of 1M HCl. Stir until all solids have dissolved. Caution: This quenching process is highly exothermic and will release HCl gas.
- **Extraction:** Transfer the mixture to a separatory funnel. Separate the organic layer. Extract the aqueous layer twice with 25 mL portions of DCM.
- **Washing:** Combine the organic layers and wash sequentially with 30 mL of 1M HCl, 30 mL of saturated sodium bicarbonate solution (caution: CO₂ evolution), and 30 mL of brine.[4]
- **Drying and Concentration:** Dry the organic layer over anhydrous magnesium sulfate (MgSO₄), filter, and concentrate the solvent using a rotary evaporator to yield the crude product.
- **Purification:** Purify the crude residue by flash column chromatography on silica gel, typically using a gradient of ethyl acetate in hexanes, to afford the pure 4-acetyl-5-methyl-1H-pyrrole-2-carbaldehyde.

Product Characterization

The purified product should be characterized using standard spectroscopic methods to confirm its structure.

- **¹H NMR:** Expect to see characteristic signals for the pyrrole N-H (a broad singlet), the aldehyde proton, the remaining pyrrole ring proton (at C3), the acetyl methyl protons, and the C5-methyl protons.
- **¹³C NMR:** Signals corresponding to the two carbonyl carbons (aldehyde and ketone), the pyrrole ring carbons, and the two methyl carbons should be observed.

- FT-IR: Look for strong carbonyl stretching bands ($\sim 1640\text{-}1680\text{ cm}^{-1}$ for the ketone and $\sim 1660\text{-}1700\text{ cm}^{-1}$ for the aldehyde) and a broad N-H stretching band ($\sim 3200\text{-}3400\text{ cm}^{-1}$).
- Mass Spectrometry: The molecular ion peak corresponding to the mass of the product ($\text{C}_8\text{H}_9\text{NO}_2$) should be present.

Troubleshooting Guide

Even with a robust protocol, challenges can arise. This guide addresses common issues encountered during the Friedel-Crafts acylation of sensitive pyrrolic substrates.

Caption: A workflow for troubleshooting common issues in pyrrole acylation.

Conclusion

The Friedel-Crafts acylation of 5-methyl-1H-pyrrole-2-carbaldehyde is a highly effective method for introducing a ketone functional group at the C4 position with high regioselectivity. The success of the reaction hinges on a clear understanding of the directing effects of the substituents and meticulous control over experimental conditions, particularly temperature and moisture. By following the detailed protocol and utilizing the troubleshooting guide provided, researchers can reliably synthesize 4-acyl-5-methyl-1H-pyrrole-2-carbaldehyde, a versatile intermediate for applications in drug discovery and materials science.

References

- Taylor, J. E., Jones, M. D., Williams, J. M., & Bull, S. D. (2010). Friedel–Crafts Acylation of Pyrroles and Indoles using 1,5-Diazabicyclo[4.3.0]non-5-ene (DBN) as a Nucleophilic Catalyst. *Organic Letters*, 12(24), 5740–5743.
- Huffman, J. W., Smith, V. J., & Padgett, L. W. (2008). Acylation of N-p-toluenesulfonylpyrrole under Friedel-Crafts conditions. Evidence for organoaluminum intermediates. *Tetrahedron*, 64(9), 2104-2112.
- BenchChem. (2025). Spectroscopic Profile of N-Acetylpyrrole: A Technical Guide.
- Sigma-Aldrich. Friedel–Crafts Acylation.

- Kilin, V., et al. (2025). Peri-Substituted Acyl Pyrrolyl Naphthalenes: Synthesis, Reactions and Photophysical Properties. *Molecules*, 30(7), 2894.
- BYJU'S. Friedel Crafts Acylation And Alkylation Reaction.
- Phadke, R. (2020). Friedel craft acylation of furan,pyrrole and thiophene|Electrophilic substitution reaction. YouTube.
- Reddy, G. S., et al. (2018). Chemoselective pyrrole dance vs. C–H functionalization/aroylation of toluenes. *Chemical Science*, 9(34), 7006-7012.
- Chem-Impex International. 1-Ethyl-5-methyl-1H-pyrrole-2-carbaldehyde.
- Sarda, S. R., et al. (2011). SELECTIVE ACETYLATION OF AROMATIC HETEROCYCLIC COMPOUNDS. *Sci. Revs. Chem. Commun.*, 1(1), 58-63.
- Katritzky, A. R., et al. (2003). Regiospecific C-Acylation of Pyrroles and Indoles Using N-Acylbenzotriazoles. *The Journal of Organic Chemistry*, 68(14), 5720–5723.
- Berthiaume, S., et al. (1991). Synthesis of 5-substituted pyrrole-2-carboxaldehydes. Part I. Generation of formal 5-lithiopyrrole-2-carboxaldehyde equivalents. *Canadian Journal of Chemistry*, 69(1), 1-8.
- Wood, J. M., Furkert, D. P., & Brimble, M. A. (2018). 2-Formylpyrrole natural products: origin, structural diversity, bioactivity and synthesis. *Natural Product Reports*, 35(10), 1045-1067.
- Wikipedia. Lewis acid catalysis.
- University of Rochester. Experiment 1: Friedel-Crafts Acylation.
- Davletshina, G. R., et al. (2023). Synthesis of Non-Aromatic Pyrroles Based on the Reaction of Carbonyl Derivatives of Acetylene with 3,3-Diaminoacrylonitriles. *Molecules*, 28(8), 3538.
- Organic Chemistry Portal. Lewis acid catalyzed acylation reactions: scope and limitations.
- Corma, A., García, H. (2003). Lewis Acids: From Conventional Homogeneous to Green Homogeneous and Heterogeneous Catalysis. *Chemical Reviews*, 103(11), 4307-4366.

- Scaiano, J. C., et al. (2023). Insights into the Friedel–Crafts Benzoylation of N-Methylpyrrole inside the Confined Space of the Self-Assembled Resorcinarene Capsule. *Organic Letters*, 25(35), 6561–6566.
- Chemistry Stack Exchange. (2019). Friedel-Crafts Alkylation of Pyrrole.
- Chemistry Steps. Friedel-Crafts Acylation.
- Wang, L., et al. (2018). Synthesis of Pyrrole-2-carbaldehyde Derivatives by Oxidative Annulation and Direct Csp³–H to C=O Oxidation. *Organic Letters*, 20(3), 632–635.
- ChemSpider. (2005). Friedel-Crafts Alkylation of pyrrole via pyrrole-2-carboxaldehyde.
- Organic Chemistry Portal. Friedel-Crafts Acylation.

Need Custom Synthesis?

BenchChem offers custom synthesis for rare earth carbides and specific isotopic labeling.

Email: info@benchchem.com or [Request Quote Online](#).

Sources

- 1. 傅-克酰基化反应 [sigmaaldrich.cn]
- 2. youtube.com [youtube.com]
- 3. byjus.com [byjus.com]
- 4. websites.umich.edu [websites.umich.edu]
- 5. Insights into the Friedel–Crafts Benzoylation of N-Methylpyrrole inside the Confined Space of the Self-Assembled Resorcinarene Capsule - PMC [pmc.ncbi.nlm.nih.gov]
- To cite this document: BenchChem. [Introduction: Navigating Electrophilic Substitution on a Substituted Pyrrole Core]. BenchChem, [2026]. [Online PDF]. Available at: [https://www.benchchem.com/product/b588716/docs#introduction-navigating-electrophilic-substitution-on-a-substituted-pyrrole-core]

Disclaimer & Data Validity:

The information provided in this document is for Research Use Only (RUO) and is strictly not intended for diagnostic or therapeutic procedures. While BenchChem strives to provide accurate protocols, we make no warranties, express or implied, regarding the fitness of this product for every specific experimental setup.

Technical Support: The protocols provided are for reference purposes. Unsure if this reagent suits your experiment?

Need Industrial/Bulk Grade? [Request Custom Synthesis Quote](#)

BenchChem

Our mission is to be the trusted global source of essential and advanced chemicals, empowering scientists and researchers to drive progress in science and industry.

Contact

Address: 3281 E Guasti Rd
Ontario, CA 91761, United States
Phone: (601) 213-4426
Email: info@benchchem.com

[Contact our Ph.D. Support Team for a compatibility check](#)