

Application Notes and Protocols: In Vitro Efficacy Testing of Kynurenic Acid Analogs

Author: BenchChem Technical Support Team. **Date:** December 2025

Compound of Interest

Compound Name: 4-Oxo(3,5,6,7,8-~2~H_5_)-1,4-dihydroquinoline-2-carboxylic acid

Cat. No.: B588624

[Get Quote](#)

Audience: Researchers, scientists, and drug development professionals.

Introduction

Kynurenic acid (KYNA), a metabolite of the tryptophan catabolism pathway, is an endogenous neuromodulator with a broad spectrum of biological activities.[1][2] It is a well-documented antagonist of ionotropic glutamate receptors, including the N-methyl-D-aspartate (NMDA), α -amino-3-hydroxy-5-methyl-4-isoxazolepropionic acid (AMPA), and kainate receptors.[3][4] Notably, KYNA exhibits a higher affinity for the glycine co-agonist site on the NMDA receptor.[3][5] Beyond its influence on excitatory neurotransmission, KYNA also interacts with the G-protein-coupled receptor 35 (GPR35) and the aryl hydrocarbon receptor (AHR), contributing to its immunomodulatory and anti-inflammatory properties.[4][6][7]

The therapeutic potential of KYNA in neurological and inflammatory disorders is significant; however, its limited ability to cross the blood-brain barrier restricts its clinical utility.[8] This has spurred the development of novel KYNA analogs with improved pharmacokinetic profiles and enhanced efficacy.[1][8] This document provides detailed protocols for a panel of in vitro assays designed to characterize and evaluate the efficacy of these kynurenic acid analogs. The described assays will enable the assessment of their receptor binding affinity, impact on cell viability and proliferation, and anti-inflammatory potential.

Signaling Pathways and Experimental Workflow

The following diagrams illustrate the primary signaling pathway of kynurenic acid and a generalized workflow for the in vitro assays described in this document.

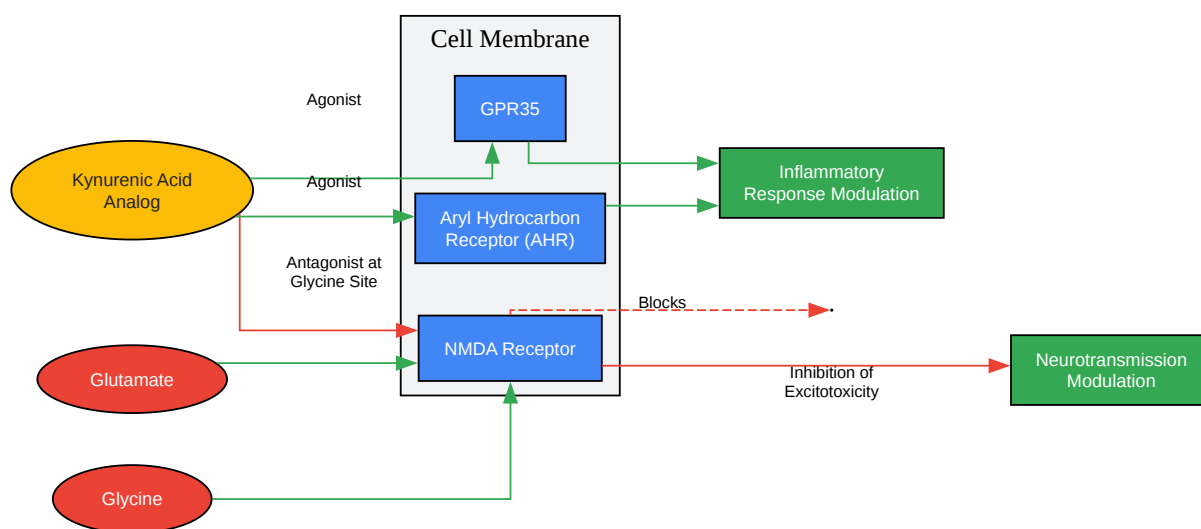

[Click to download full resolution via product page](#)

Caption: Kynurenic Acid Analog Signaling Pathway.

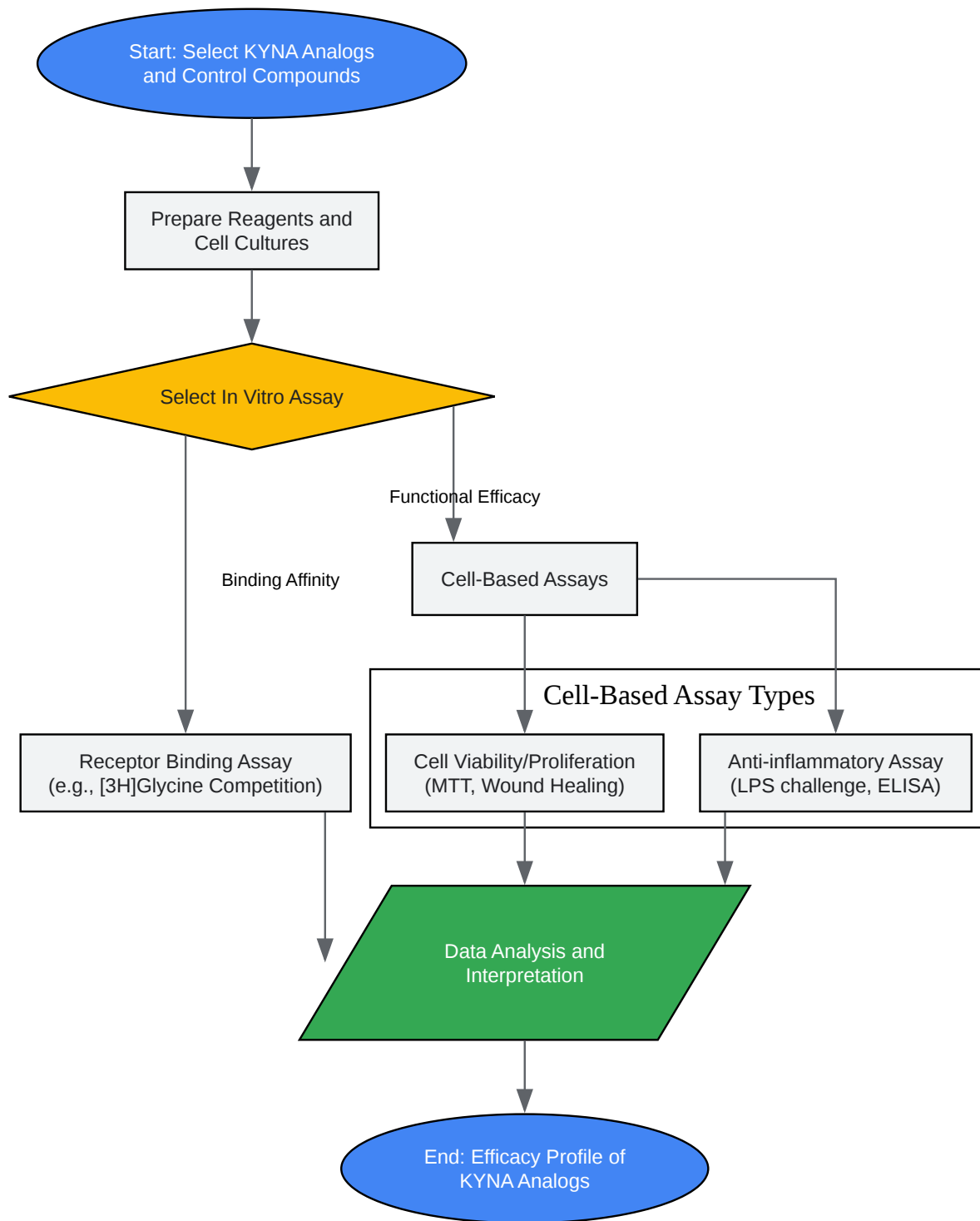

[Click to download full resolution via product page](#)

Caption: General Experimental Workflow for In Vitro Testing.

Data Presentation

The following tables summarize quantitative data for kynurenic acid and its analogs from various in vitro studies.

Table 1: NMDA Receptor Binding Affinity of Kynurenic Acid Analogs

Compound	Assay Type	Preparation	IC50 (nM)	pKi	Reference
5,7-diBr-KYNA	[3H]Glycine Binding	Rat Cortex/Hippo campus P2 Membranes	-	7.2	[5]
5,7-diCl-KYNA	[3H]Glycine Binding	Rat Cortex/Hippo campus P2 Membranes	-	-	[5]
5-I,7-Cl-KYNA	[3H]Glycine Binding	Rat Cortex/Hippo campus P2 Membranes	29	-	[5]
L-689,560	[3H]Glycine Binding	Rat Cortex/Hippo campus P2 Membranes	-	7.98	[5]

Table 2: Effects of Kynurenic Acid Analogs on Cell Viability and Proliferation

Compound	Cell Line	Assay	Concentration	Effect	Reference
KYNA	Human Corneal Epithelial Cells (pRSV-T)	Neutral Red	1-100 μ M	No effect on viability after 24h and 48h.	[9]
KYNA	Human Conjunctival Cells (HC0597)	Neutral Red	1-100 μ M	Significant transient reduction in viability at 24h.	[9]
KYNA	Gastric Cancer Cells (AGS)	MTT	0-300 μ M	Concentration-dependent inhibition of viability (IC ₅₀ \approx 250 μ M).	[10]
KYNA	Gastric Cancer Cells (AGS)	Wound Healing	150-250 μ M	Concentration-dependent inhibition of cell migration.	[10]
KYNA	Gastric Cancer Cells (AGS)	Colony Formation	150-250 μ M	Concentration-dependent inhibition of proliferation.	[10]
SZR-72	Pancreatic Acinar Cells	Propidium Iodide	250 μ M	Significantly reduced L-ornithine-induced toxicity.	[11]

Table 3: Anti-inflammatory Effects of Kynurenic Acid Analogs

Compound	Cell Type/System	Inflammatory Stimulus	Measured Marker	Concentration	Effect	Reference
KYNA	Microglia-enriched Cultures	Lipopolysaccharide (LPS)	CXCL10	1 μ M	Reduced LPS-induced CXCL10 levels.	[12]
SZR104	Microglia-enriched Cultures	Lipopolysaccharide (LPS)	CXCL10	1 μ M	Reduced LPS-induced CXCL10 levels.	[12]
SZR-72	RA Patient Whole Blood	Staphylococcus aureus	TNF- α	500 μ M	Attenuated induced TNF- α production.	[7]
SZR-72	RA Patient Whole Blood	Staphylococcus aureus	Calprotectin (S100A8/9)	500 μ M	Attenuated induced Calprotectin production.	[7]
SZR-72	RA Patient Whole Blood	Staphylococcus aureus	EN-RAGE (S100A12)	500 μ M	Attenuated induced EN-RAGE production.	[7]

Experimental Protocols

Protocol 1: NMDA Receptor Binding Assay ([³H]Glycine Competition)

This protocol is adapted from methodologies used to assess the affinity of KYNA analogs for the glycine binding site on the NMDA receptor.[5]

Objective: To determine the binding affinity (IC₅₀, K_i) of KYNA analogs by measuring their ability to displace the radioligand [³H]glycine from its binding site on the NMDA receptor in rat brain membrane preparations.

Materials:

- Rat cortex/hippocampus tissue
- [³H]Glycine (specific activity ~40-60 Ci/mmol)
- Kynurenic acid analogs (test compounds)
- Glycine (for non-specific binding determination)
- Tris-HCl buffer (50 mM, pH 7.4)
- Homogenizer
- Centrifuge (refrigerated)
- Scintillation counter and vials
- Glass fiber filters (e.g., Whatman GF/B)
- Filtration manifold

Procedure:

- Membrane Preparation:
 1. Dissect cortex and hippocampus from rat brains on ice.
 2. Homogenize the tissue in ice-cold 50 mM Tris-HCl buffer.
 3. Centrifuge the homogenate at 1,000 x g for 10 minutes at 4°C to remove nuclei and large debris.
 4. Collect the supernatant and centrifuge at 40,000 x g for 20 minutes at 4°C.

5. Resuspend the resulting pellet (P2 membrane fraction) in fresh buffer and repeat the centrifugation step three times to wash the membranes.
 6. Resuspend the final pellet in a known volume of buffer and determine the protein concentration using a standard method (e.g., Bradford assay). Store aliquots at -80°C .
- Binding Assay:
 1. Prepare assay tubes with a final volume of 500 μL containing:
 - 50 mM Tris-HCl buffer (pH 7.4)
 - A fixed concentration of [^3H]Glycine (e.g., 10 nM)
 - Varying concentrations of the KYNA analog (e.g., 1 nM to 1 mM)
 - Rat cortical membrane preparation (50-100 μg of protein)
 2. For total binding, omit the KYNA analog.
 3. For non-specific binding, add a high concentration of unlabeled glycine (e.g., 1 mM).
 4. Incubate the tubes at 4°C for 30 minutes.
 - Filtration and Measurement:
 1. Rapidly terminate the binding reaction by vacuum filtration through glass fiber filters pre-soaked in buffer.
 2. Wash the filters three times with 4 mL of ice-cold buffer to remove unbound radioligand.
 3. Place the filters in scintillation vials, add scintillation cocktail, and allow to equilibrate.
 4. Measure the radioactivity using a scintillation counter.
 - Data Analysis:
 1. Calculate specific binding by subtracting non-specific binding from total binding.

2. Plot the percentage of specific [³H]glycine binding against the log concentration of the KYNA analog.
3. Determine the IC₅₀ value (the concentration of analog that inhibits 50% of specific binding) using non-linear regression analysis.
4. Calculate the inhibitor constant (K_i) using the Cheng-Prusoff equation: $K_i = IC_{50} / (1 + [L]/K_d)$, where [L] is the concentration of the radioligand and K_d is its dissociation constant.

Protocol 2: Cell Viability and Proliferation Assays

These protocols are based on common methods to assess the cytotoxic or cytostatic effects of KYNA analogs.[\[9\]](#)[\[10\]](#)

A. MTT Assay for Metabolic Activity/Viability

Objective: To assess cell viability by measuring the metabolic activity of cells, specifically the reduction of MTT (3-(4,5-dimethylthiazol-2-yl)-2,5-diphenyltetrazolium bromide) to formazan by mitochondrial dehydrogenases.

Materials:

- Selected cell line (e.g., AGS human gastric cancer cells, H9C2 cells)[\[10\]](#)[\[13\]](#)
- Complete cell culture medium (e.g., RPMI with 10% FBS)
- KYNA analogs
- MTT solution (5 mg/mL in PBS)
- Solubilization solution (e.g., DMSO or 0.01 M HCl in 10% SDS)
- 96-well plates
- Microplate reader

Procedure:

- Cell Seeding: Seed cells into a 96-well plate at a density of 1×10^4 cells/well and incubate overnight.[10]
- Compound Treatment: Treat the cells with various concentrations of KYNA analogs (e.g., 0-300 μ M) for a specified duration (e.g., 24 or 48 hours).[10] Include a vehicle control (e.g., DMSO at <0.1%).
- MTT Incubation: Add 10 μ L of MTT solution to each well and incubate for 4 hours at 37°C.
- Solubilization: Remove the medium and add 100 μ L of solubilization solution to each well to dissolve the formazan crystals.
- Measurement: Read the absorbance at 570 nm using a microplate reader.
- Data Analysis: Express the results as a percentage of the vehicle-treated control. Plot cell viability against analog concentration to determine the IC50 value.

B. Wound Healing (Scratch) Assay for Cell Migration

Objective: To evaluate the effect of KYNA analogs on cell migration, a key process in proliferation and wound repair.

Materials:

- Selected cell line (e.g., AGS cells, human keratinocytes)[10]
- Complete cell culture medium
- 6-well or 12-well plates
- Sterile 200 μ L pipette tip
- Microscope with a camera

Procedure:

- Create Monolayer: Seed cells in plates and grow to 90-100% confluence.

- Create "Wound": Gently and evenly scratch the cell monolayer with a sterile pipette tip to create a cell-free gap.
- Wash and Treat: Wash the wells with PBS to remove detached cells. Add fresh medium containing various concentrations of the KYNA analog.
- Image Acquisition: Capture images of the scratch at time 0 and at subsequent time points (e.g., 12, 24 hours).
- Data Analysis: Measure the width of the scratch at different points for each condition and time point. Calculate the percentage of wound closure relative to the initial scratch area.

Protocol 3: Anti-inflammatory Assay (LPS-stimulated Cytokine Release)

This protocol is based on methods used to assess the immunomodulatory effects of KYNA analogs in vitro.[\[7\]](#)[\[12\]](#)

Objective: To determine the ability of KYNA analogs to suppress the production of pro-inflammatory cytokines (e.g., TNF- α , CXCL10) from immune cells stimulated with lipopolysaccharide (LPS).

Materials:

- Microglia-enriched cultures, peripheral blood mononuclear cells (PBMCs), or a monocyte cell line (e.g., U-937).[\[12\]](#)[\[14\]](#)
- Complete cell culture medium
- Lipopolysaccharide (LPS) from *E. coli*
- KYNA analogs
- ELISA kits for the target cytokine (e.g., human TNF- α)
- 96-well plates

Procedure:

- Cell Seeding: Seed the cells in a 96-well plate at an appropriate density.
- Pre-treatment: Pre-incubate the cells with various concentrations of the KYNA analog for a specified time (e.g., 30 minutes to 2 hours).[7]
- Inflammatory Challenge: Add LPS to the wells to a final concentration known to induce a robust cytokine response (e.g., 20 ng/mL for microglia, higher for PBMCs).[12] Include control wells (no treatment, analog only, LPS only).
- Incubation: Incubate the plate for a suitable period to allow for cytokine production (e.g., 18-24 hours).[7]
- Supernatant Collection: Centrifuge the plate to pellet the cells and carefully collect the supernatant.
- Cytokine Quantification: Measure the concentration of the target cytokine in the supernatants using an ELISA kit according to the manufacturer's instructions.
- Data Analysis: Calculate the percentage inhibition of cytokine production by the KYNA analog compared to the LPS-only control. Plot the inhibition against the analog concentration to determine the IC50 value.

Need Custom Synthesis?

BenchChem offers custom synthesis for rare earth carbides and specific isotopic labeling.

Email: info@benchchem.com or [Request Quote Online](#).

References

- 1. preprints.org [preprints.org]
- 2. researchgate.net [researchgate.net]
- 3. publicatio.bibl.u-szeged.hu [publicatio.bibl.u-szeged.hu]
- 4. Does kynurenic acid act on nicotinic receptors? An assessment of the evidence - PMC [pmc.ncbi.nlm.nih.gov]

- 5. Kynurenic acid analogues with improved affinity and selectivity for the glycine site on the N-methyl-D-aspartate receptor from rat brain - PubMed [pubmed.ncbi.nlm.nih.gov]
- 6. researchgate.net [researchgate.net]
- 7. Kynurenic Acid Analog Attenuates the Production of Tumor Necrosis Factor- α , Calgranulins (S100A 8/9 and S100A 12), and the Secretion of HNP1–3 and Stimulates the Production of Tumor Necrosis Factor-Stimulated Gene-6 in Whole Blood Cultures of Patients With Rheumatoid Arthritis - PMC [pmc.ncbi.nlm.nih.gov]
- 8. A novel kynurenic acid analogue: a comparison with kynurenic acid. An in vitro electrophysiological study - PubMed [pubmed.ncbi.nlm.nih.gov]
- 9. mdpi.com [mdpi.com]
- 10. mdpi.com [mdpi.com]
- 11. Kynurenic Acid and Its Analogue SZR-72 Ameliorate the Severity of Experimental Acute Necrotizing Pancreatitis - PMC [pmc.ncbi.nlm.nih.gov]
- 12. Kynurenic Acid and Its Analog SZR104 Exhibit Strong Antiinflammatory Effects and Alter the Intracellular Distribution and Methylation Patterns of H3 Histones in Immunochallenged Microglia-Enriched Cultures of Newborn Rat Brains - PMC [pmc.ncbi.nlm.nih.gov]
- 13. Kynurenic Acid: A Novel Player in Cardioprotection against Myocardial Ischemia/Reperfusion Injuries [mdpi.com]
- 14. researchgate.net [researchgate.net]
- To cite this document: BenchChem. [Application Notes and Protocols: In Vitro Efficacy Testing of Kynurenic Acid Analogs]. BenchChem, [2025]. [Online PDF]. Available at: [https://www.benchchem.com/product/b588624#in-vitro-assay-for-testing-the-efficacy-of-kynurenic-acid-analogs]

Disclaimer & Data Validity:

The information provided in this document is for Research Use Only (RUO) and is strictly not intended for diagnostic or therapeutic procedures. While BenchChem strives to provide accurate protocols, we make no warranties, express or implied, regarding the fitness of this product for every specific experimental setup.

Technical Support: The protocols provided are for reference purposes. Unsure if this reagent suits your experiment? [[Contact our Ph.D. Support Team for a compatibility check](#)]

Need Industrial/Bulk Grade? [Request Custom Synthesis Quote](#)

BenchChem

Our mission is to be the trusted global source of essential and advanced chemicals, empowering scientists and researchers to drive progress in science and industry.

Contact

Address: 3281 E Guasti Rd

Ontario, CA 91761, United States

Phone: (601) 213-4426

Email: info@benchchem.com