

Eperisone-d10 Hydrochloride: A Technical Guide for Researchers

Author: BenchChem Technical Support Team. **Date:** December 2025

Compound of Interest

Compound Name: *Eperisone-d10hydrochloride*

Cat. No.: *B587842*

[Get Quote](#)

For Researchers, Scientists, and Drug Development Professionals

Introduction

Eperisone-d10 hydrochloride is the deuterated analog of Eperisone hydrochloride, a centrally acting muscle relaxant. The strategic replacement of ten hydrogen atoms with deuterium isotopes renders it an ideal internal standard for quantitative bioanalytical studies, particularly those employing liquid chromatography-mass spectrometry (LC-MS). This technical guide provides an in-depth overview of Eperisone-d10 hydrochloride, its research applications, and detailed methodologies for its use.

Physicochemical Properties

Eperisone-d10 hydrochloride is a stable, isotopically labeled form of Eperisone hydrochloride. Its key physicochemical properties are summarized in the table below.

Property	Value	References
Chemical Name	1-(4-Ethylphenyl)-2-methyl-3-(1-piperidinyl-d10)-1-propanone Hydrochloride	[1]
CAS Number	1246819-46-4	[2][3][4]
Molecular Formula	C ₁₇ H ₁₆ D ₁₀ ClNO	[3][4][5]
Molecular Weight	305.91 g/mol	[3][4][5][6]
Purity	>95% (HPLC)	[1][7]
Appearance	Off-White Solid	[5]
Solubility	Soluble in Methanol	[5]
Storage	-20°C	[5]

Research Use: Internal Standard in Quantitative Analysis

The primary research application of Eperisone-d10 hydrochloride is as an internal standard (IS) in bioanalytical methods to quantify Eperisone in biological matrices such as plasma and serum.[6] The use of a stable isotope-labeled internal standard is the gold standard in LC-MS based bioanalysis as it offers superior accuracy and precision.[8][9][10] Eperisone-d10 hydrochloride co-elutes with the unlabeled analyte and exhibits identical ionization efficiency, thereby compensating for variations in sample preparation, injection volume, and matrix effects. [8][9][10]

Experimental Protocol: Quantification of Eperisone in Human Plasma using LC-MS/MS with Eperisone-d10 Hydrochloride as an Internal Standard

This section outlines a representative experimental protocol for the determination of Eperisone in human plasma. This protocol is a composite based on established methods for Eperisone analysis, adapted for the use of Eperisone-d10 hydrochloride as the internal standard.

Preparation of Stock and Working Solutions

- Eperisone Stock Solution (1 mg/mL): Accurately weigh 10 mg of Eperisone hydrochloride and dissolve in 10 mL of methanol.
- Eperisone-d10 Hydrochloride (Internal Standard) Stock Solution (1 mg/mL): Accurately weigh 1 mg of Eperisone-d10 hydrochloride and dissolve in 1 mL of methanol.
- Working Solutions: Prepare serial dilutions of the Eperisone stock solution with a 50:50 mixture of methanol and water to create calibration standards and quality control (QC) samples.
- Internal Standard Working Solution (100 ng/mL): Dilute the Eperisone-d10 hydrochloride stock solution with methanol.

Preparation of Calibration Standards and Quality Control Samples

- Spike blank human plasma with the appropriate Eperisone working solutions to achieve final concentrations for the calibration curve (e.g., 0.1, 0.5, 1, 5, 10, 50, 100 ng/mL).
- Prepare QC samples at low, medium, and high concentrations in a similar manner.

Sample Preparation (Protein Precipitation)

- To 100 μ L of plasma sample (calibration standard, QC, or unknown), add 20 μ L of the Eperisone-d10 hydrochloride internal standard working solution (100 ng/mL).
- Vortex for 30 seconds.
- Add 300 μ L of acetonitrile to precipitate proteins.
- Vortex for 2 minutes.
- Centrifuge at 10,000 rpm for 10 minutes.
- Transfer the supernatant to a clean tube and evaporate to dryness under a gentle stream of nitrogen at 40°C.

- Reconstitute the residue in 100 μ L of the mobile phase.
- Inject an aliquot (e.g., 5-10 μ L) into the LC-MS/MS system.

LC-MS/MS Conditions

Parameter	Condition
LC System	Agilent 1200 Series or equivalent
Column	C18 column (e.g., 50 x 2.1 mm, 3.5 μ m)
Mobile Phase	A: 0.1% Formic acid in Water B: 0.1% Formic acid in Acetonitrile
Gradient	0-0.5 min: 20% B 0.5-2.5 min: 20-80% B 2.5-3.0 min: 80% B 3.0-3.1 min: 80-20% B 3.1-5.0 min: 20% B
Flow Rate	0.4 mL/min
Column Temperature	40°C
MS System	Triple quadrupole mass spectrometer
Ionization Mode	Electrospray Ionization (ESI), Positive
MRM Transitions	Eperisone: m/z 260.2 \rightarrow 98.1 Eperisone-d10: m/z 270.2 \rightarrow 108.1 (projected)
Collision Energy	Optimized for each transition

Note: The MRM transition for Eperisone-d10 is projected and should be optimized experimentally.

Experimental Workflow Diagram

LC-MS/MS Bioanalytical Workflow

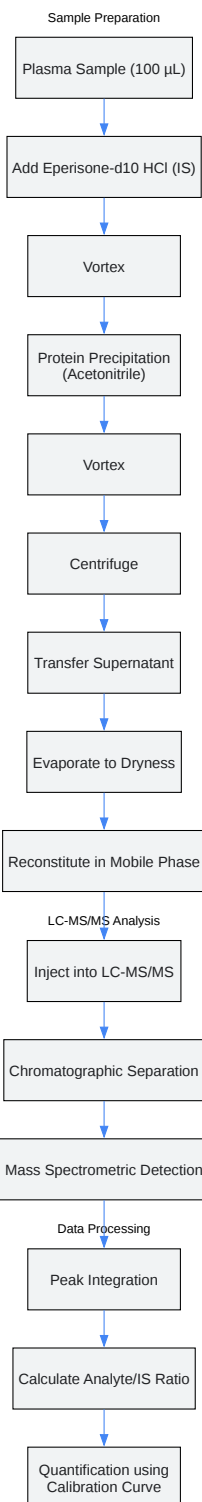

[Click to download full resolution via product page](#)

Caption: Workflow for the bioanalysis of Eperisone using Eperisone-d10 HCl.

Mechanism of Action of Eperisone

Eperisone hydrochloride, the non-deuterated parent compound, exerts its muscle relaxant effects through a multi-faceted mechanism of action.^{[11][12][13]} It primarily acts on the central nervous system and vascular smooth muscle.

Inhibition of Spinal Reflexes

Eperisone suppresses both mono- and polysynaptic reflexes within the spinal cord.^{[11][12]} This action is thought to be mediated by the inhibition of gamma-efferent firing, which reduces the sensitivity of muscle spindles to stretch.^[11] The overall effect is a decrease in muscle tone and alleviation of spasticity.^[11]

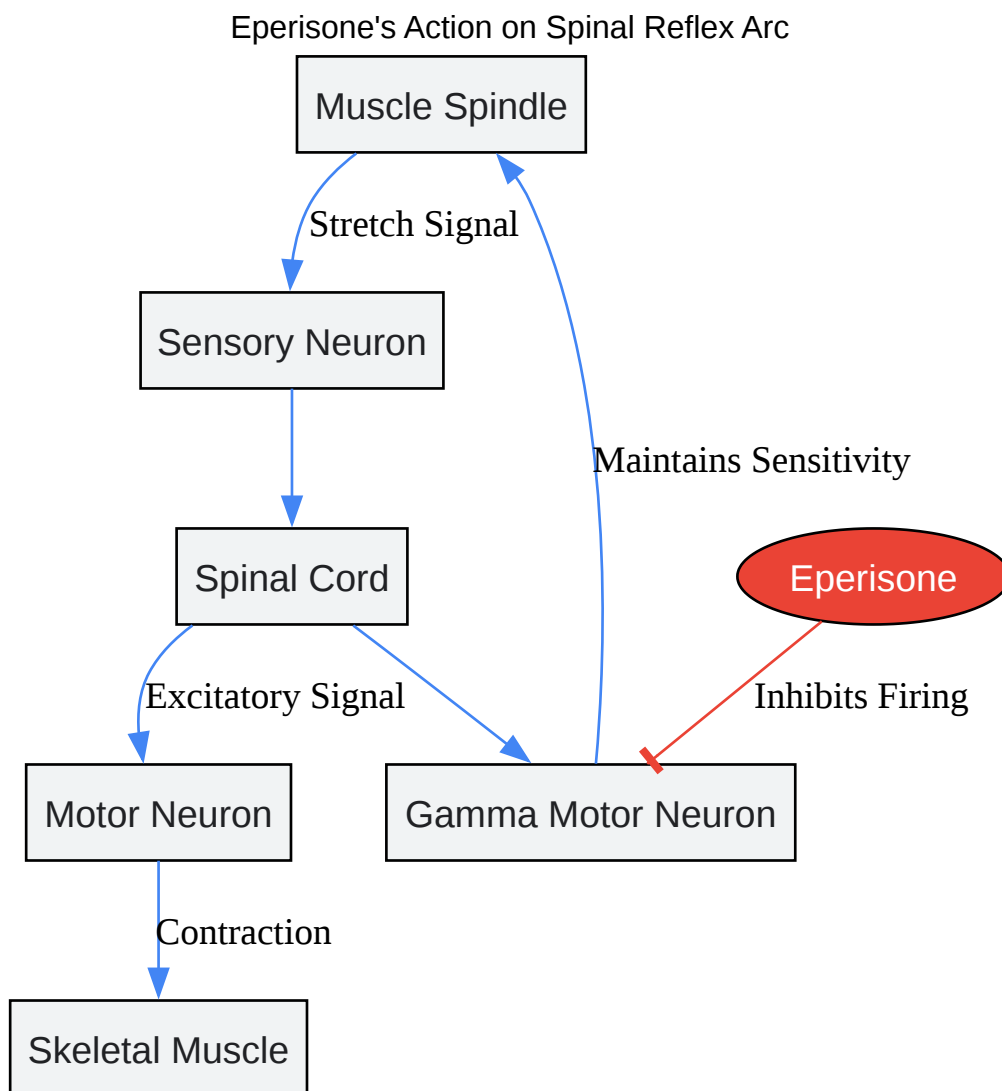

[Click to download full resolution via product page](#)

Caption: Eperisone inhibits the spinal reflex arc by suppressing gamma motor neuron firing.

Vasodilation via Calcium Channel Antagonism

Eperisone exhibits vasodilatory properties by acting as a calcium channel antagonist in vascular smooth muscle cells.[11][14] By blocking voltage-dependent calcium channels, it inhibits the influx of calcium ions, leading to smooth muscle relaxation and increased blood

flow.[11][14] This can help to alleviate the vicious cycle of muscle contraction, ischemia, and pain.[11]

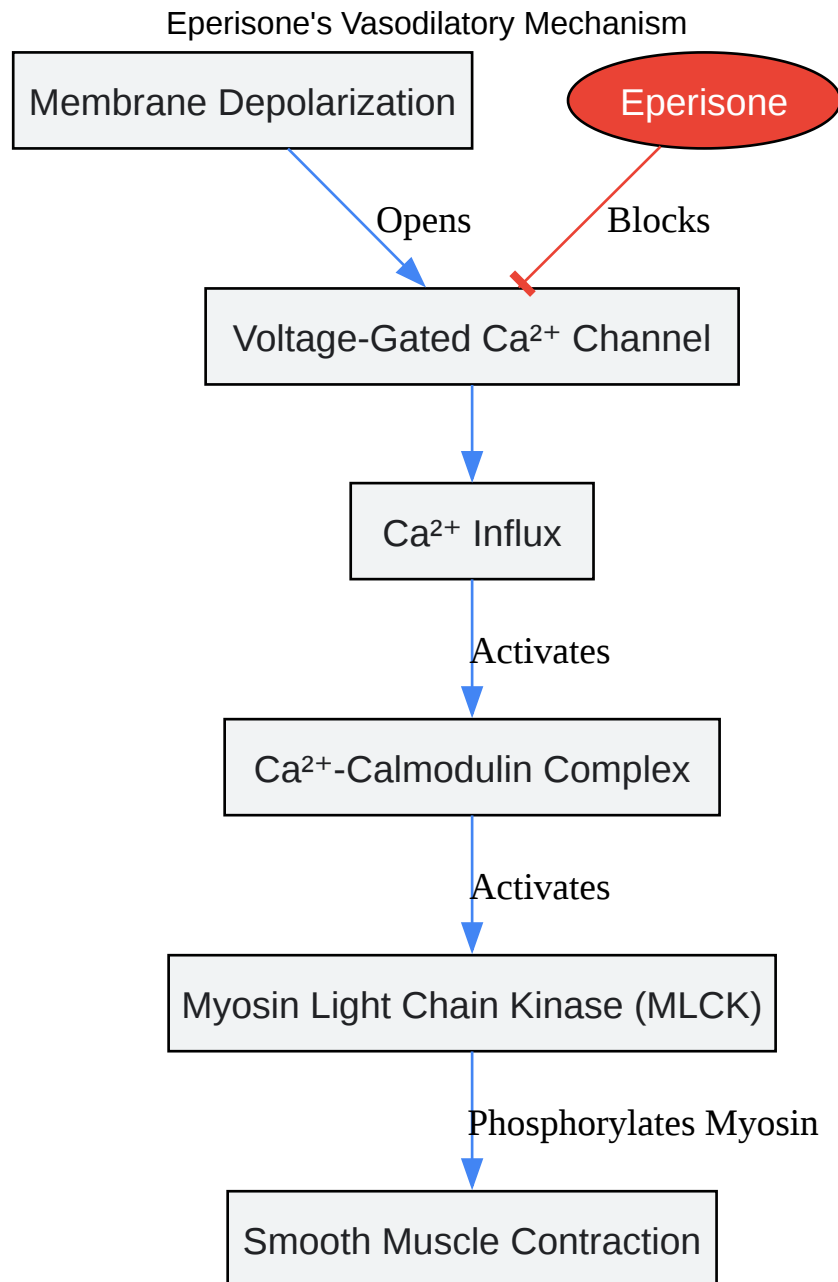

[Click to download full resolution via product page](#)

Caption: Eperisone blocks voltage-gated calcium channels, leading to vasodilation.

Potential Interaction with P2X7 Receptors

Recent research suggests that Eperisone may also act as a potent antagonist of the P2X7 receptor.[15][16][17] P2X7 receptors are ATP-gated ion channels involved in inflammation and pain signaling.[15] Antagonism of these receptors could contribute to the analgesic effects of Eperisone.[15][16]

Potential Role of Eperisone as a P2X7 Antagonist

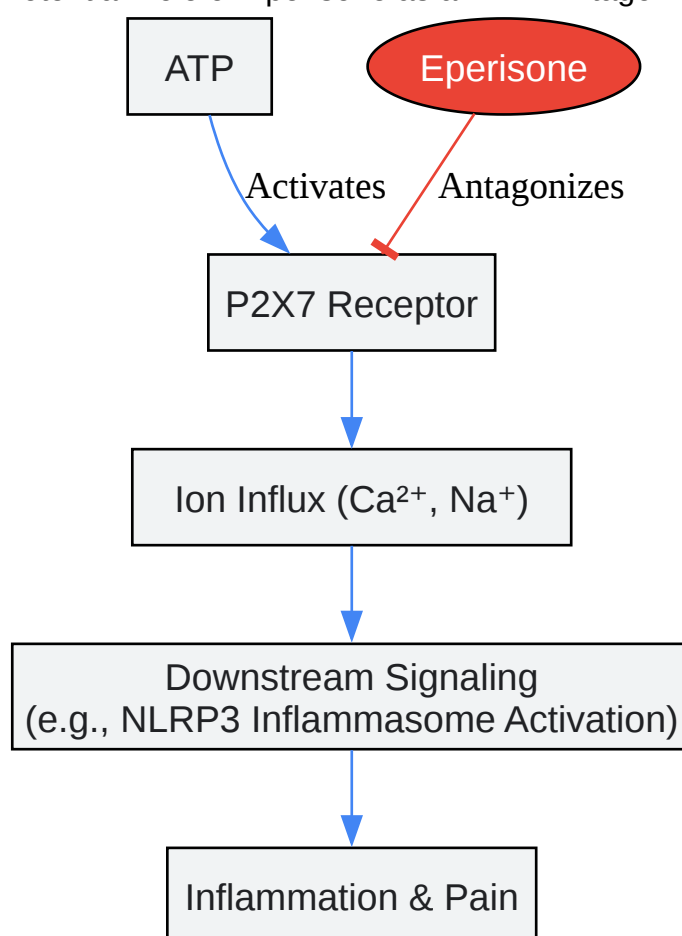

[Click to download full resolution via product page](#)

Caption: Eperisone may exert analgesic effects through antagonism of the P2X7 receptor.

Conclusion

Eperisone-d10 hydrochloride is an indispensable tool for researchers in drug metabolism, pharmacokinetics, and clinical pharmacology. Its use as an internal standard ensures the reliability and accuracy of bioanalytical data for its non-deuterated counterpart, Eperisone. A thorough understanding of Eperisone's multifaceted mechanism of action, encompassing the central nervous system and peripheral vasculature, is crucial for its continued investigation and therapeutic application. This guide provides a foundational resource for scientists and professionals engaged in the study of this important muscle relaxant.

Need Custom Synthesis?

BenchChem offers custom synthesis for rare earth carbides and specific isotopic labeling.

Email: info@benchchem.com or [Request Quote Online](#).

References

- 1. Eperisone-d10 Hydrochloride | LGC Standards [[lgcstandards.com](https://www.lgcstandards.com)]
- 2. [theclinivex.com](https://www.theclinivex.com) [[theclinivex.com](https://www.theclinivex.com)]
- 3. [vivanls.com](https://www.vivanls.com) [[vivanls.com](https://www.vivanls.com)]
- 4. Eperisone Hydrochloride | CAS No- 56839-43-1 | Simson Pharma Limited [[simsonpharma.com](https://www.simsonpharma.com)]
- 5. [mybiosource.com](https://www.mybiosource.com) [[mybiosource.com](https://www.mybiosource.com)]
- 6. [medchemexpress.com](https://www.medchemexpress.com) [[medchemexpress.com](https://www.medchemexpress.com)]
- 7. Eperisone-d10 Hydrochloride | LGC Standards [[lgcstandards.com](https://www.lgcstandards.com)]
- 8. [lcms.cz](https://www.lcms.cz) [[lcms.cz](https://www.lcms.cz)]
- 9. [chromforum.org](https://www.chromforum.org) [[chromforum.org](https://www.chromforum.org)]
- 10. [scispace.com](https://www.scispace.com) [[scispace.com](https://www.scispace.com)]
- 11. [droracle.ai](https://www.droracle.ai) [[droracle.ai](https://www.droracle.ai)]
- 12. What is the mechanism of Eperisone Hydrochloride? [synapse.patsnap.com]
- 13. [mims.com](https://www.mims.com) [[mims.com](https://www.mims.com)]
- 14. Eperisone, an antispastic agent, possesses vasodilating actions on the guinea-pig basilar artery - PubMed [pubmed.ncbi.nlm.nih.gov]
- 15. [researchgate.net](https://www.researchgate.net) [[researchgate.net](https://www.researchgate.net)]

- 16. Eperisone Hydrochloride, a Muscle Relaxant, Is a Potent P2X7 Receptor Antagonist - PubMed [pubmed.ncbi.nlm.nih.gov]
- 17. Eperisone Hydrochloride, a Muscle Relaxant, Is a Potent P2X7 Receptor Antagonist. | Semantic Scholar [semanticscholar.org]
- To cite this document: BenchChem. [Eperisone-d10 Hydrochloride: A Technical Guide for Researchers]. BenchChem, [2025]. [Online PDF]. Available at: [https://www.benchchem.com/product/b587842#what-is-eperisone-d10-hydrochloride-and-its-research-use]

Disclaimer & Data Validity:

The information provided in this document is for Research Use Only (RUO) and is strictly not intended for diagnostic or therapeutic procedures. While BenchChem strives to provide accurate protocols, we make no warranties, express or implied, regarding the fitness of this product for every specific experimental setup.

Technical Support: The protocols provided are for reference purposes. Unsure if this reagent suits your experiment? [[Contact our Ph.D. Support Team for a compatibility check](#)]

Need Industrial/Bulk Grade? [Request Custom Synthesis Quote](#)

BenchChem

Our mission is to be the trusted global source of essential and advanced chemicals, empowering scientists and researchers to drive progress in science and industry.

Contact

Address: 3281 E Guasti Rd
Ontario, CA 91761, United States
Phone: (601) 213-4426
Email: info@benchchem.com