

Application Notes and Protocols for Targeted Proteomics Using a Labeled Cystine Standard

Author: BenchChem Technical Support Team. **Date:** May 2026

Compound of Interest

Compound Name: *N,N'*-Diacetyl-L-cystine Bis(*tert*-Butyl) Diester-*d*6

Cat. No.: B587422

[Get Quote](#)

For Researchers, Scientists, and Drug Development Professionals

Introduction

Targeted proteomics has emerged as a powerful methodology for the precise quantification of specific proteins within complex biological samples. This approach offers significant advantages in drug development and biomedical research by enabling the accurate measurement of protein biomarkers, monitoring drug-target engagement, and elucidating cellular signaling pathways. Stable Isotope Labeling by Amino Acids in Cell Culture (SILAC) is a widely adopted metabolic labeling strategy that provides high accuracy in relative protein quantification.[1][2] While lysine and arginine are commonly used for SILAC, the incorporation of isotopically labeled cysteine, such as L-Cystine-¹⁵N₂, offers unique benefits for studying proteins involved in critical cellular processes like redox signaling and disulfide bond formation. [1][3]

Cysteine's reactive thiol group makes it a crucial residue in enzyme catalysis and redox regulation.[3] Utilizing a labeled cystine standard allows for a focused analysis of these specific protein populations. This application note provides a detailed workflow and experimental

protocols for targeted proteomics using a labeled cystine standard, from cell culture and metabolic labeling to mass spectrometry analysis and data interpretation.

Principle of the Method

The core principle of this workflow involves metabolically labeling proteins in cultured cells with a "heavy" isotope of cystine. Two populations of cells are cultured in media that are identical except for the isotopic composition of cystine. One population ("light") is grown in a medium containing natural abundance L-Cystine, while the other ("heavy") is cultured in a medium containing a stable isotope-labeled L-Cystine (e.g., L-Cystine- $^{15}\text{N}_2$ or L-Cystine- $^{13}\text{C}_3,^{15}\text{N}$).^{[1][3]} Over several cell divisions, the "heavy" cystine is incorporated into all newly synthesized proteins in the heavy-labeled cell population.

Following an experimental treatment (e.g., drug administration), the "light" (control) and "heavy" (treated) cell populations are combined. Proteins are then extracted, digested into peptides, and analyzed by mass spectrometry (MS). The mass spectrometer detects pairs of peptides that are chemically identical but differ in mass due to the incorporated stable isotope. The ratio of the ion intensities of the heavy and light peptides provides a precise measure of the relative abundance of the protein between the two conditions.

Experimental Workflow

The overall experimental workflow for targeted proteomics using a labeled cystine standard is depicted below.



[Click to download full resolution via product page](#)

Caption: Experimental workflow for targeted proteomics using a labeled cystine standard.

Signaling Pathway Example: Keap1-Nrf2 Pathway

Targeted proteomics with labeled cystine is particularly well-suited for studying signaling pathways involved in oxidative stress response, such as the Keap1-Nrf2 pathway. Cysteine residues in Keap1 are critical for its function as a sensor of oxidative stress.

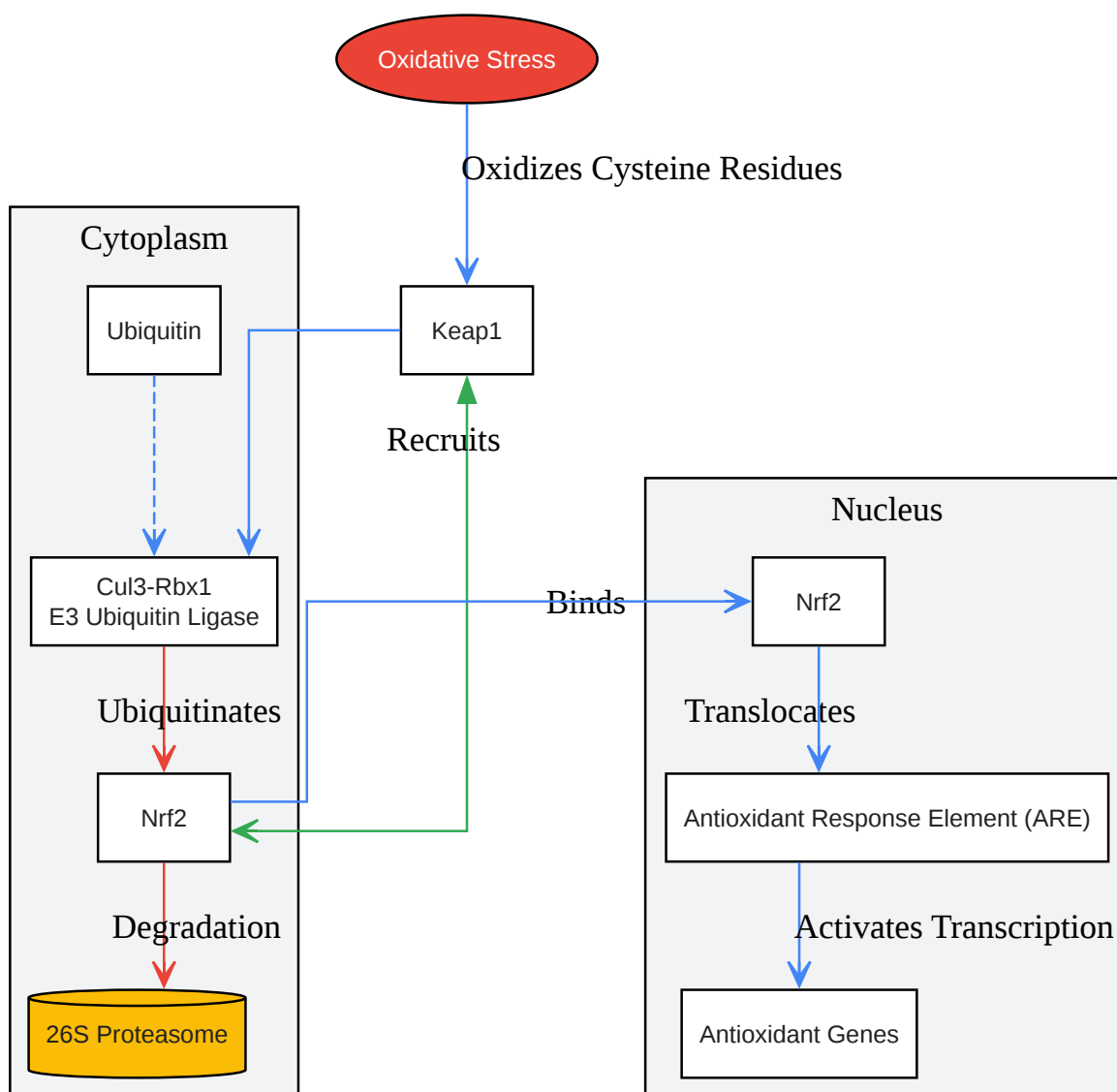

[Click to download full resolution via product page](#)

Caption: Simplified diagram of the Keap1-Nrf2 signaling pathway.

Detailed Experimental Protocols

Materials and Reagents

- Cell culture medium deficient in L-Cystine
- Dialyzed Fetal Bovine Serum (dFBS)
- Penicillin-Streptomycin
- Natural abundance ("light") L-Cystine
- Stable isotope-labeled ("heavy") L-Cystine (e.g., L-Cystine-¹⁵N₂)
- Phosphate-Buffered Saline (PBS)
- Lysis buffer (e.g., RIPA buffer)
- Protease and phosphatase inhibitors
- BCA Protein Assay Kit
- Dithiothreitol (DTT)
- Iodoacetamide (IAA)
- Trypsin (mass spectrometry grade)
- Ammonium bicarbonate
- Formic acid
- C18 spin columns for peptide desalting

Protocol 1: Cell Culture and Metabolic Labeling

- Media Preparation: Prepare "light" and "heavy" SILAC media by supplementing L-Cystine-deficient medium with 10% dFBS, 1x Penicillin-Streptomycin, and either "light" or "heavy" L-Cystine to a final concentration of approximately 0.2 mM.[3] The use of dialyzed FBS is crucial to minimize the introduction of unlabeled cystine.[3]
- Cell Adaptation: Culture cells in the "heavy" SILAC medium for at least 5-6 cell doublings to ensure complete incorporation of the labeled amino acid.[4] Culture a parallel set of cells in

the "light" medium.

- Verification of Incorporation (Optional but Recommended): After sufficient cell doublings, harvest a small number of cells from the "heavy" population. Extract proteins, perform a tryptic digest, and analyze by mass spectrometry to confirm >95% incorporation of the heavy L-Cystine.[4]

Protocol 2: Experimental Treatment and Sample Collection

- Treatment: Once complete incorporation is achieved, apply the experimental treatment (e.g., drug compound) to the "heavy" labeled cells. The "light" labeled cells will serve as the control.
- Harvesting: After the desired treatment period, wash both "light" and "heavy" cell populations with ice-cold PBS and harvest them.
- Cell Lysis and Protein Quantification: Combine the "light" and "heavy" cell pellets at a 1:1 ratio based on cell number or protein amount.[4] Lyse the combined cell pellet in an appropriate lysis buffer containing protease and phosphatase inhibitors. Determine the total protein concentration of the lysate using a BCA assay.[3][4]

Protocol 3: Protein Digestion and Peptide Preparation

- Reduction and Alkylation:
 - Take a desired amount of protein (e.g., 50-100 µg).
 - Reduce disulfide bonds by adding DTT to a final concentration of 10 mM and incubating at 56°C for 30 minutes.[3]
 - Alkylate free cysteine residues by adding iodoacetamide (IAA) to a final concentration of 20-55 mM and incubating in the dark at room temperature for 20-30 minutes.[3][4]
- Tryptic Digestion:
 - Dilute the protein sample with 50 mM ammonium bicarbonate to reduce the concentration of detergents.

- Add trypsin at a 1:50 (trypsin:protein) ratio and incubate overnight at 37°C.[4]
- Peptide Desalting:
 - Acidify the peptide solution with formic acid to a final concentration of 0.1%. [4]
 - Desalt the peptides using C18 spin columns according to the manufacturer's protocol.[4]
 - Elute the peptides and dry them in a vacuum centrifuge.[4]

Protocol 4: LC-MS/MS Analysis and Data Interpretation

- LC-MS/MS: Resuspend the dried peptides in a suitable solvent (e.g., 0.1% formic acid) for mass spectrometry analysis.[4] Analyze the peptide mixture using a high-resolution mass spectrometer coupled with a liquid chromatography system.
- Data Analysis: Process the raw mass spectrometry data using a proteomics software package that supports SILAC quantification (e.g., MaxQuant, Proteome Discoverer).[4] The software will identify peptides and proteins and calculate the heavy-to-light (H/L) ratio for each cysteine-containing peptide. This ratio reflects the relative abundance of the protein between the treated and control samples.[4]

Data Presentation

Quantitative data from targeted proteomics experiments should be summarized in a clear and structured format to facilitate comparison and interpretation.

Table 1: Protein Quantification Results

Protein ID	Gene Name	Peptide Sequence	Light Intensity	Heavy Intensity	H/L Ratio	Regulation
P04637	TP53	VCPVCR...	1.20E+08	2.45E+08	2.04	Upregulated
Q06609	NFE2L2	LDEETGE FLPI...	3.50E+07	1.50E+07	0.43	Downregulated
P62937	PPIA	FKEGSC...	5.10E+08	5.05E+08	0.99	Unchanged

Table 2: Pathway Analysis of Differentially Expressed Proteins

Pathway Name	Number of Proteins	p-value
Nrf2 Pathway	15	1.3E-05
Glutathione Metabolism	10	2.5E-04
Drug Metabolism	8	5.1E-03

Conclusion

The targeted proteomics workflow using a labeled cystine standard provides a robust and accurate method for quantifying specific proteins, particularly those involved in redox regulation and other cysteine-dependent cellular processes. The detailed protocols and data presentation guidelines provided in this application note offer a comprehensive framework for researchers, scientists, and drug development professionals to successfully implement this powerful technique in their studies. Careful experimental design and execution are critical for obtaining high-quality, reproducible data that can provide valuable insights into protein function and disease mechanisms.

Need Custom Synthesis?

BenchChem offers custom synthesis for rare earth carbides and specific isotopic labeling.

Email: info@benchchem.com or [Request Quote Online](#).

References

- 1. [benchchem.com](https://www.benchchem.com) [[benchchem.com](https://www.benchchem.com)]
- 2. Quantitative proteomics using stable isotope labeling with amino acids in cell culture - PubMed [pubmed.ncbi.nlm.nih.gov]
- 3. [benchchem.com](https://www.benchchem.com) [[benchchem.com](https://www.benchchem.com)]
- 4. [benchchem.com](https://www.benchchem.com) [[benchchem.com](https://www.benchchem.com)]
- To cite this document: BenchChem. [Application Notes and Protocols for Targeted Proteomics Using a Labeled Cystine Standard]. BenchChem, [2026]. [Online PDF]. Available

at: [<https://www.benchchem.com/product/b587422/docs#application-notes-and-protocols-for-targeted-proteomics-using-a-labeled-cystine-standard>]

Disclaimer & Data Validity:

The information provided in this document is for Research Use Only (RUO) and is strictly not intended for diagnostic or therapeutic procedures. While BenchChem strives to provide accurate protocols, we make no warranties, express or implied, regarding the fitness of this product for every specific experimental setup.

Technical Support: The protocols provided are for reference purposes. Unsure if this reagent suits your experiment?

Need Industrial/Bulk Grade? [Request Custom Synthesis Quote](#)

BenchChem

Our mission is to be the trusted global source of essential and advanced chemicals, empowering scientists and researchers to drive progress in science and industry.

Contact

Address: 3281 E Guasti Rd
Ontario, CA 91761, United States
Phone: (601) 213-4426
Email: info@benchchem.com

[Contact our Ph.D. Support Team for a compatibility check](#)