

# A Technical Guide to the Natural Occurrence of sym-Homospermidine

**Author:** BenchChem Technical Support Team. **Date:** May 2026

## Compound of Interest

Compound Name:	<i>sym-Homo Spermidine Trihydrochloride</i>
CAS No.:	189340-78-1
Cat. No.:	B586725

[Get Quote](#)

## Abstract

Symmetrical homospermidine (sym-HSPD), a structural isomer of the more common polyamine spermidine, is a triamine with significant, albeit specialized, roles across different domains of life. Unlike the ubiquitous nature of canonical polyamines like putrescine and spermidine, sym-homospermidine exhibits a more sporadic distribution, appearing as a major polyamine in specific groups of bacteria and plants where it serves critical functions, from nitrogen fixation to chemical defense. This technical guide provides an in-depth exploration of the natural occurrence of sym-homospermidine, its distinct biosynthetic pathways, physiological significance, and the analytical methodologies required for its robust detection and quantification. This document is intended for researchers, scientists, and drug development professionals seeking to understand and leverage the unique biology of this non-canonical polyamine.

## Introduction: The Polyamines and the Unique Case of sym-Homospermidine

Polyamines are low-molecular-weight aliphatic polycations that are essential for a multitude of cellular processes, including cell growth, proliferation, differentiation, and stress response.[1][2] They exert their functions primarily through electrostatic interactions with negatively charged macromolecules like DNA, RNA, and proteins.[1] While putrescine, spermidine, and spermine are considered the canonical polyamines in most eukaryotic and prokaryotic cells, a diverse array of "unusual" polyamines exists in nature.

Among these is sym-homospermidine, chemically defined as N-(4-aminobutyl)butane-1,4-diamine.[3] First isolated from the leaves of Sandalwood (*Santalum album* L.), its symmetrical structure—two butane moieties flanking a central secondary amine—distinguishes it from its asymmetrical isomer, spermidine, which has propylene and butylene groups.[4][5] This structural difference, arising from distinct biosynthetic routes, dictates its specific functional roles and its limited, yet significant, natural distribution.

## Distribution and Natural Occurrence

The presence of sym-homospermidine is not universal but is prominent in specific phylogenetic lineages, suggesting its evolution was driven by selective pressures requiring its unique biochemical properties.

### In the Plant Kingdom

In plants, sym-homospermidine is most famously a key, pathway-specific intermediate in the biosynthesis of pyrrolizidine alkaloids (PAs).[6][7] PAs are a large class of heterocyclic secondary metabolites that serve as potent chemical defenses against herbivores.

Consequently, sym-homospermidine is found in various PA-producing plant families, including:

- Asteraceae (e.g., *Senecio vernalis*)[6][8]
- Boraginaceae (e.g., *Heliotropium* species)[9]
- Fabaceae (e.g., *Lathyrus sativus*)[10]

Beyond its role in alkaloid synthesis, it has been identified in Sandalwood (*Santalum album*) and the aquatic plant water hyacinth (*Eichhornia crassipes*), where it can be the predominant polyamine in root tissues.[11][12]

## In Bacteria and Cyanobacteria

The distribution of sym-homospermidine is particularly noteworthy in the bacterial domain. It is found in various proteobacteria, such as the phototrophic bacterium *Blastochloris viridis* (formerly *Rhodospseudomonas viridis*), and is implicated in critical processes like biofilm formation and pathogenesis in organisms like *Pseudomonas aeruginosa*.<sup>[3][13]</sup>

Its presence is especially pronounced in nitrogen-fixing cyanobacteria. A strong correlation exists where cyanobacterial species capable of nitrogen fixation almost invariably contain sym-homospermidine as their major polyamine, whereas non-fixing species primarily utilize spermidine.<sup>[14][15][16]</sup> This suggests a specialized role in the biochemistry of nitrogen fixation or the protection of the nitrogenase enzyme complex.

The table below summarizes the occurrence of sym-homospermidine in selected organisms.

Domain	Organism	Observed Concentration / Significance	Reference(s)
Plantae	<i>Eichhornia crassipes</i> (Water Hyacinth)	9.9–46.4 nmol/g fresh weight in roots	<sup>[12]</sup>
	<i>Santalum album</i> (Sandalwood)	Identified as a major polyamine	<sup>[4][11]</sup>
	<i>Senecio vernalis</i>	Precursor for pyrrolizidine alkaloids	<sup>[6][8]</sup>
Bacteria	Nitrogen-fixing Cyanobacteria	Major polyamine, correlated with N <sub>2</sub> fixation	<sup>[16]</sup>
	<i>Blastochloris viridis</i>	Site of early enzyme characterization	<sup>[3]</sup>
	<i>Pseudomonas aeruginosa</i>	Implicated in biofilm formation	<sup>[13]</sup>

## Biosynthesis: Two Distinct Enzymatic Pathways

The synthesis of sym-homospermidine is catalyzed by the enzyme homospermidine synthase (HSS). Critically, two different, evolutionarily distinct forms of this enzyme exist, utilizing different substrates. This divergence is a prime example of convergent evolution for the synthesis of the same molecule.

- Bacterial HSS (EC 2.5.1.44): This enzyme, found in bacteria and cyanobacteria, catalyzes the NAD<sup>+</sup>-dependent condensation of two molecules of putrescine.<sup>[13]</sup> The reaction proceeds in three steps: (1) the NAD<sup>+</sup>-dependent dehydrogenation of one putrescine molecule to form an imine intermediate (dehydroputrescine), (2) the transfer of the resulting 4-aminobutylidene group to a second putrescine molecule, and (3) the reduction of the final imine intermediate to yield sym-homospermidine, releasing ammonia.<sup>[3]</sup>
  - Overall Reaction:  $2 \text{ Putrescine} \rightarrow \text{sym-Homospermidine} + \text{NH}_3 + \text{H}^+$
- Plant HSS (EC 2.5.1.45): In plants, HSS is the first committed enzyme in the PA biosynthetic pathway.<sup>[6][17]</sup> This enzyme evolved from deoxyhypusine synthase (DHS), an essential enzyme in primary metabolism, via gene duplication and neofunctionalization.<sup>[7][8]</sup> Unlike its bacterial counterpart, plant HSS catalyzes the transfer of a 4-aminobutyl group from spermidine to putrescine.<sup>[6][13]</sup>
  - Overall Reaction:  $\text{Putrescine} + \text{Spermidine} \rightarrow \text{sym-Homospermidine} + 1,3\text{-Diaminopropane}$

The existence of these two pathways highlights the importance of this molecule in the specific contexts where it is found, justifying the independent evolution of synthetic machinery.

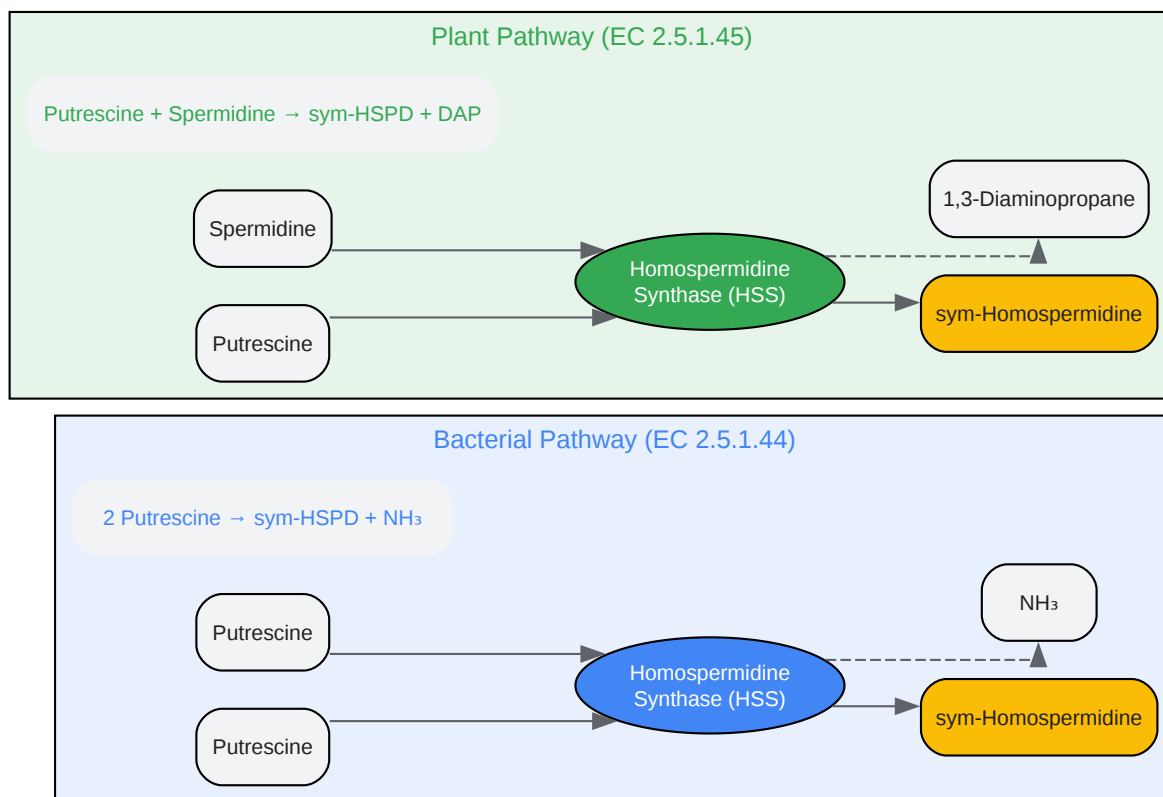

[Click to download full resolution via product page](#)

**Fig. 1:** Divergent biosynthetic pathways of sym-homospermidine.

## Physiological Roles and Significance

The functions of sym-homospermidine are as specialized as its distribution.

- **Precursor for Secondary Metabolites:** As previously noted, the primary role of sym-homospermidine in many plants is to serve as the backbone for the biosynthesis of pyrrolizidine alkaloids, which are crucial for defense against herbivory.[7] The subsequent oxidation of sym-homospermidine by a copper-containing amine oxidase (HSO) is a key step that forms the bicyclic pyrrolizidine ring structure.[18]

- **Role in Abiotic Stress:** Like other polyamines, sym-homospermidine is implicated in plant responses to abiotic stress, although its specific mechanisms are less understood than those of spermidine or spermine.[19] Polyamines, in general, are known to stabilize membranes, scavenge reactive oxygen species, and modulate ion channels under stress conditions.[19] [20]
- **Bacterial Physiology:** In bacteria, sym-homospermidine is integral to normal growth and development. Its involvement in biofilm formation is particularly relevant for drug development, as biofilms contribute significantly to antibiotic resistance and the persistence of chronic infections.[2][13] Targeting HSS in pathogenic bacteria could therefore represent a novel antimicrobial strategy.
- **Nitrogen Fixation:** In cyanobacteria, the strong link between sym-homospermidine content and nitrogen fixation suggests a direct or indirect role.[16] It may be involved in protecting the highly oxygen-sensitive nitrogenase enzyme, maintaining the structural integrity of the specialized heterocyst cells where fixation occurs, or regulating gene expression related to the process.

## Analytical Methodologies: A Practical Guide

Accurate quantification of sym-homospermidine is essential for studying its metabolism and function. Due to their low volatility and high polarity, polyamines typically require derivatization for effective separation and detection by chromatographic methods.

### General Workflow

The analysis of sym-homospermidine from biological matrices follows a multi-step process involving extraction, derivatization, separation, and detection.

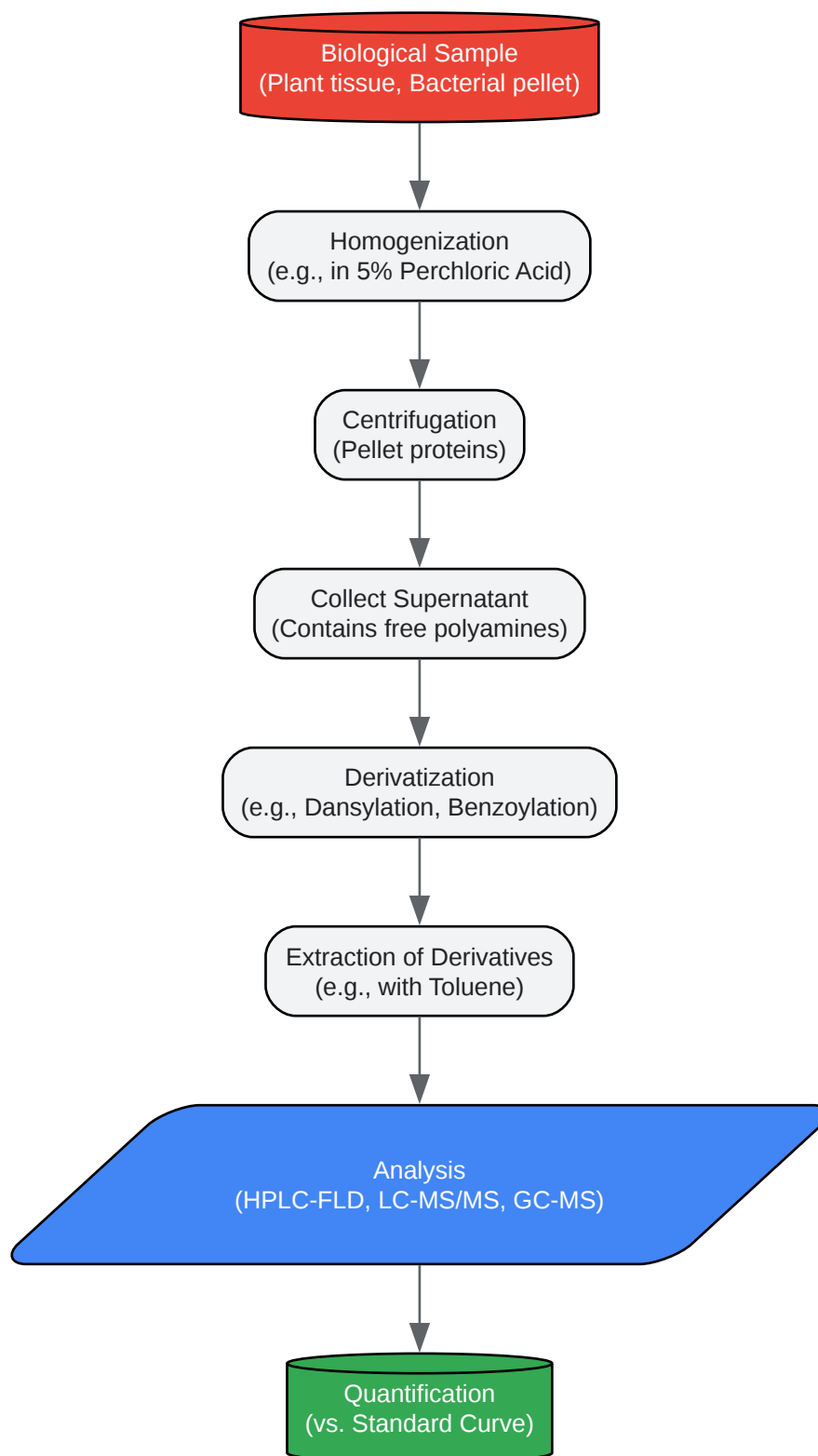

[Click to download full resolution via product page](#)

**Fig. 2:** General workflow for polyamine analysis.

## Experimental Protocol: HPLC Analysis with Pre-Column Dansylation

This protocol provides a robust and widely used method for quantifying polyamines, including sym-homospermidine, using High-Performance Liquid Chromatography (HPLC) with fluorescence detection.

Causality: Dansyl chloride reacts with primary and secondary amines under alkaline conditions to form highly fluorescent derivatives. This increases detection sensitivity and renders the polar polyamines suitable for separation on a non-polar (e.g., C18) reverse-phase column.

Materials:

- Perchloric acid (PCA), 5% (v/v)
- Saturated sodium carbonate solution
- Dansyl chloride solution (10 mg/mL in acetone)
- Proline (100 mg/mL in water)
- Toluene
- Acetonitrile (HPLC grade)
- Water (HPLC grade)
- sym-Homospermidine standard
- Internal standard (e.g., 1,7-diaminoheptane)

Procedure:

- Extraction:
  - Homogenize ~100 mg of fresh tissue or cell pellet in 1 mL of ice-cold 5% PCA.
  - Add a known amount of internal standard.

- Incubate on ice for 1 hour to precipitate proteins and nucleic acids.
- Centrifuge at 15,000 x g for 20 min at 4°C.
- Transfer the supernatant to a new tube. This is the crude polyamine extract.
- Derivatization (Self-Validating System):
  - To 100 µL of the extract (or standard), add 200 µL of saturated sodium carbonate. The high pH is critical for the reaction.
  - Add 200 µL of dansyl chloride solution. The excess of reagent ensures complete derivatization.
  - Vortex and incubate in the dark at 60°C for 1 hour.
  - Add 100 µL of proline solution to react with and quench the excess dansyl chloride. This step is crucial to prevent reagent peaks from interfering with analysis.
  - Vortex and incubate for 30 min.
- Extraction of Derivatives:
  - Add 500 µL of toluene to the reaction mixture.
  - Vortex vigorously for 1 min to extract the dansylated polyamines into the organic phase.
  - Centrifuge at 3,000 x g for 5 min to separate the phases.
  - Carefully transfer the upper toluene layer to a new tube and evaporate to dryness under a stream of nitrogen.
  - Reconstitute the dried residue in 200 µL of acetonitrile.
- HPLC Analysis:
  - Column: C18 reverse-phase column (e.g., 4.6 x 150 mm, 5 µm).

- Mobile Phase: A gradient of acetonitrile and water. A typical gradient might be from 50% to 95% acetonitrile over 30 minutes.
- Flow Rate: 1.0 mL/min.
- Detection: Fluorescence detector set to Excitation  $\lambda = 340$  nm and Emission  $\lambda = 510$  nm.
- Injection Volume: 20  $\mu$ L.
- Quantification:
  - Run sym-homospermidine standards of known concentrations to generate a standard curve (Peak Area Ratio of Standard/Internal Standard vs. Concentration).
  - Calculate the concentration in the unknown samples by interpolating their peak area ratios from the standard curve.

Note: For higher specificity and sensitivity, especially in complex matrices, Liquid Chromatography-Tandem Mass Spectrometry (LC-MS/MS) is an increasingly preferred method, which can often be performed without derivatization.[21][22]

## Future Perspectives and Applications

The study of sym-homospermidine continues to open new avenues in both basic and applied science.

- Drug Development: The bacterial homospermidine synthase (HSS) is a validated target for the development of novel antibiotics.[13] Inhibitors of HSS could disrupt biofilm formation and pathogenesis, providing a new strategy to combat antibiotic-resistant infections.
- Biotechnology and Agriculture: Understanding the role of sym-homospermidine in nitrogen fixation could lead to strategies for enhancing this process in cyanobacteria or engineering it into other organisms. Similarly, manipulating the PA pathway in crops could enhance their resistance to herbivores or abiotic stresses.[19][23]
- Biomaterials: As a naturally occurring polyamine, sym-homospermidine can be explored as a monomer for the synthesis of novel bio-based polymers and polyamides with unique properties.[24][25]

## Conclusion

sym-Homospermidine stands out as a fascinating example of molecular diversity and functional specialization in the world of polyamines. Its restricted but critical presence in diverse organisms, from plants defending themselves with complex alkaloids to bacteria forming resilient biofilms, underscores its evolutionary importance. The existence of two distinct biosynthetic pathways further highlights its value in these specialized biological niches. With robust analytical methods now available for its quantification, future research is poised to further unravel its complex roles and unlock its potential for applications in medicine, agriculture, and biotechnology.

## References

- Kuttan, R., Radhakrishnan, A. N., Spande, T., & Witkop, B. (1971). sym-Homospermidine, a naturally occurring polyamine. *Biochemistry*, 10(3), 361-365. [\[Link\]](#)<sup>[5]</sup>
- Kuttan, R., & Radhakrishnan, A. N. (1972). Studies on the biosynthesis of sym-homospermidine in sandal (*Santalum album* L.). *Biochemical Journal*, 127(1), 61-67. [\[Link\]](#)<sup>[4]</sup>
- ACS Publications. (n.d.). sym-Homospermidine, a naturally occurring polyamine. *Biochemistry*. [\[Link\]](#)<sup>[9]</sup>
- Reim, S., et al. (2021). Insights into polyamine metabolism: homospermidine is double-oxidized in two discrete steps by a single copper-containing amine oxidase in pyrrolizidine alkaloid biosynthesis. *Plant Physiology*, 185(2), 334-349. [\[Link\]](#)<sup>[18]</sup>
- International Union of Biochemistry and Molecular Biology. (n.d.). EC 2.5.1.44. IUBMB Enzyme Nomenclature. [\[Link\]](#)<sup>[3]</sup>
- Srivenugopal, K. S., & Adiga, P. R. (1980). Enzymic synthesis of sym-homospermidine in *Lathyrus sativus* (grass pea) seedlings. *Biochemical Journal*, 190(2), 461-464. [\[Link\]](#)<sup>[10]</sup>
- Grokipedia. (n.d.). Homospermidine synthase. [\[Link\]](#)<sup>[13]</sup>
- Fujihara, S., Nakashima, T., Kurogochi, Y., & Yamaguchi, M. (1986). Identification and Determination of sym-Homospermidine in Roots of Water Hyacinth, *Eichhornia crassipes* SOLMS. *Agricultural and Biological Chemistry*, 50(4), 897-901. [\[Link\]](#)

- Hamana, K., & Hosoya, H. (2017). *Additional analysis of cyanobacterial polyamines Distributions of spermidine, homospermidine, spermine, and thermospermine within the phylum Cyanobacteria*. *Microbial Resources and Systematics*, 33, 1-13. [[Link](#)][14]
- Lykholay, A. N., et al. (2021). *Recent Advances in the Synthesis of Polyamine Derivatives and Their Applications*. *Molecules*, 26(21), 6569. [[Link](#)][1]
- Chen, D., Shao, Q., Yin, L., Younis, A., & Zheng, B. (2019). *Polyamine function in plants: metabolism, regulation on development, and roles in abiotic stress responses*. *Frontiers in Plant Science*, 9, 1945. [[Link](#)][19]
- Romero, C., et al. (2018). *Determination of Underivatized Polyamines: A Review of Analytical Methods and Applications*. *Analytica Chimica Acta*, 1042, 1-16. [[Link](#)][21]
- Li, Y., et al. (2023). *Rational engineering of homospermidine synthase for enhanced catalytic efficiency toward spermidine synthesis*. *Journal of Biological Chemistry*, 299(12), 105436. [[Link](#)][26]
- Gstoettenbauer, A. V., et al. (2023). *Quantitative Endogenous Polyamine Analysis via Capillary Electrophoresis/Mass Spectrometry: Characterization and Practical Considerations*. *Journal of the American Society for Mass Spectrometry*, 34(1), 108-117. [[Link](#)][27]
- Hamana, K., et al. (1988). *Distribution on sym-homospermidine in eubacteria, cyanobacteria, algae and ferns*. *FEMS Microbiology Letters*, 50(1), 11-16. [[Link](#)][15]
- Annenkov, V. V., et al. (2018). *Synthesis of biomimetic polyamines*. *ResearchGate*. [[Link](#)][24]
- Lee, Y., et al. (2023). *A bacterial spermidine biosynthetic pathway via carboxyamino-propylagmatine*. *Proceedings of the National Academy of Sciences*, 120(44), e2309141120. [[Link](#)][2]
- Hamana, K., Miyagawa, K., & Matsuzaki, S. (1983). *Occurrence of sym-homospermidine as the major polyamine in nitrogen-fixing cyanobacteria*. *Biochemical and Biophysical Research Communications*, 112(2), 606-613. [[Link](#)][16]

- Ober, D., & Hartmann, T. (1999). *Homospermidine synthase, the first pathway-specific enzyme of pyrrolizidine alkaloid biosynthesis, evolved from deoxyhypusine synthase. Proceedings of the National Academy of Sciences*, 96(26), 14777-14782. [[Link](#)][6]
- Cakan, O., et al. (2023). *The optimal method to measure polyamines in serum by using HPLC fluorescence detector. Acta Pharmaceutica Scientia*, 61(1), 91-102. [[Link](#)][28]
- Puyang, X., et al. (2015). *The Effect of Exogenous Spermidine Concentration on Polyamine Metabolism and Salt Tolerance in Zoysiagrass (Zoysia japonica Steud) Subjected to Short-Term Salinity Stress. Frontiers in Plant Science*, 6, 971. [[Link](#)][23]
- Wu, G., et al. (2017). *Enzymatic Synthesis of Biobased Polyesters and Polyamides. Macromolecules*, 50(21), 8367-8385. [[Link](#)][25]
- Pál, M., et al. (2021). *Interactions of Polyamines and Phytohormones in Plant Response to Abiotic Stress. International Journal of Molecular Sciences*, 22(24), 13485. [[Link](#)][20]
- Butt, A. M., et al. (2021). *Simultaneous quantification of eight polyamines in biological samples. Journal of Chromatography B*, 1162, 122485. [[Link](#)][22]
- Böttcher, F., Adolph, R. D., & Hartmann, T. (1993). *Homospermidine synthase, the first pathway-specific enzyme in pyrrolizidine alkaloid biosynthesis. Phytochemistry*, 32(3), 679-689. [[Link](#)][17]
- Ober, D., & Hartmann, T. (2000). *Molecular evolution by change of function. Alkaloid-specific homospermidine synthase retained all properties of deoxyhypusine synthase except binding the eIF5A precursor protein. Journal of Biological Chemistry*, 275(20), 15282-15288. [[Link](#)][7]
- Ober, D., & Hartmann, T. (1999). *Homospermidine synthase, the first pathway-specific enzyme of pyrrolizidine alkaloid biosynthesis, evolved from deoxyhypusine synthase. PubMed. [[Link](#)][8]*

### Need Custom Synthesis?

BenchChem offers custom synthesis for rare earth carbides and specific isotopic labeling.

Email: [info@benchchem.com](mailto:info@benchchem.com) or [Request Quote Online](#).

## Sources

- [1. Recent Advances in the Synthesis of Polyamine Derivatives and Their Applications - PMC \[pmc.ncbi.nlm.nih.gov\]](#)
- [2. A bacterial spermidine biosynthetic pathway via carboxyaminopropylagmatine - PMC \[pmc.ncbi.nlm.nih.gov\]](#)
- [3. EC 2.5.1.44 \[iubmb.qmul.ac.uk\]](#)
- [4. Studies on the biosynthesis of sym-homospermidine in sandal \(\*Santalum album\* L.\) - PubMed \[pubmed.ncbi.nlm.nih.gov\]](#)
- [5. sym-Homospermidine, a naturally occurring polyamine - PubMed \[pubmed.ncbi.nlm.nih.gov\]](#)
- [6. Homospermidine synthase, the first pathway-specific enzyme of pyrrolizidine alkaloid biosynthesis, evolved from deoxyhypusine synthase - PMC \[pmc.ncbi.nlm.nih.gov\]](#)
- [7. Molecular evolution by change of function. Alkaloid-specific homospermidine synthase retained all properties of deoxyhypusine synthase except binding the eIF5A precursor protein - PubMed \[pubmed.ncbi.nlm.nih.gov\]](#)
- [8. Homospermidine synthase, the first pathway-specific enzyme of pyrrolizidine alkaloid biosynthesis, evolved from deoxyhypusine synthase - PubMed \[pubmed.ncbi.nlm.nih.gov\]](#)
- [9. pubs.acs.org \[pubs.acs.org\]](#)
- [10. Enzymic synthesis of sym-homospermidine in \*Lathyrus sativus\* \(grass pea\) seedlings - PMC \[pmc.ncbi.nlm.nih.gov\]](#)
- [11. researchgate.net \[researchgate.net\]](#)
- [12. Identification and Determination of sym-Homospermidine in Roots of Water Hyacinth, \*Eichhornia crassipes\* SOLMS \[jstage.jst.go.jp\]](#)
- [13. grokipedia.com \[grokipedia.com\]](#)
- [14. jsrms.jp \[jsrms.jp\]](#)
- [15. researchgate.net \[researchgate.net\]](#)
- [16. Occurrence of sym-homospermidine as the major polyamine in nitrogen-fixing cyanobacteria - PubMed \[pubmed.ncbi.nlm.nih.gov\]](#)
- [17. mdpi.com \[mdpi.com\]](#)
- [18. Insights into polyamine metabolism: homospermidine is double-oxidized in two discrete steps by a single copper-containing amine oxidase in pyrrolizidine alkaloid biosynthesis - PMC \[pmc.ncbi.nlm.nih.gov\]](#)

- [19. Polyamines and abiotic stress tolerance in plants - PMC \[pmc.ncbi.nlm.nih.gov\]](#)
- [20. mdpi.com \[mdpi.com\]](#)
- [21. researchgate.net \[researchgate.net\]](#)
- [22. Polyamines in biological samples: Rapid and robust quantification by solid-phase extraction online-coupled to liquid chromatography–tandem mass spectrometry - PMC \[pmc.ncbi.nlm.nih.gov\]](#)
- [23. Frontiers | The Effect of Exogenous Spermidine Concentration on Polyamine Metabolism and Salt Tolerance in Zoysiagrass \(Zoysia japonica Steud\) Subjected to Short-Term Salinity Stress \[frontiersin.org\]](#)
- [24. researchgate.net \[researchgate.net\]](#)
- [25. mdpi.com \[mdpi.com\]](#)
- [26. Rational engineering of homospermidine synthase for enhanced catalytic efficiency toward spermidine synthesis - PMC \[pmc.ncbi.nlm.nih.gov\]](#)
- [27. Quantitative Endogenous Polyamine Analysis via Capillary Electrophoresis/Mass Spectrometry: Characterization and Practical Considerations - PMC \[pmc.ncbi.nlm.nih.gov\]](#)
- [28. medipol.edu.tr \[medipol.edu.tr\]](#)
- To cite this document: BenchChem. [A Technical Guide to the Natural Occurrence of sym-Homospermidine]. BenchChem, [2026]. [Online PDF]. Available at: [\[https://www.benchchem.com/product/b586725/docs#a-technical-guide-to-the-natural-occurrence-of-sym-homospermidine\]](https://www.benchchem.com/product/b586725/docs#a-technical-guide-to-the-natural-occurrence-of-sym-homospermidine)

---

### Disclaimer & Data Validity:

The information provided in this document is for Research Use Only (RUO) and is strictly not intended for diagnostic or therapeutic procedures. While BenchChem strives to provide accurate protocols, we make no warranties, express or implied, regarding the fitness of this product for every specific experimental setup.

**Technical Support:** The protocols provided are for reference purposes. Unsure if this reagent suits your experiment?

**Need Industrial/Bulk Grade?** [Request Custom Synthesis Quote](#)

# BenchChem

Our mission is to be the trusted global source of essential and advanced chemicals, empowering scientists and researchers to drive progress in science and industry.

## Contact

Address: 3281 E Guasti Rd

Ontario, CA 91761, United States

Phone: (601) 213-4426

Email: [info@benchchem.com](mailto:info@benchchem.com)

[Contact our Ph.D. Support Team for a compatibility check](#)