

# Technical Guide: Febuxostat-d7 in Bioanalytical Quantitation

**Author:** BenchChem Technical Support Team. **Date:** May 2026

## Compound of Interest

Compound Name: Febuxostat-d7

CAS No.: 1285539-74-3

Cat. No.: B585829

[Get Quote](#)

## Mechanism of Action, Protocol Design, and Validation Strategies

### Executive Summary

In the high-throughput quantification of Febuxostat (a selective xanthine oxidase inhibitor) via LC-MS/MS, the use of a stable isotope-labeled internal standard (SIL-IS) is not merely a procedural formality but a critical physicochemical control. **Febuxostat-d7** serves as the gold standard for this purpose.[1][2] Unlike structural analogs (e.g., indomethacin), **Febuxostat-d7** provides near-perfect tracking of the analyte through extraction, chromatography, and ionization.

This guide dissects the "mechanism" of **Febuxostat-d7**—defined here not as pharmacological activity, but as the physicochemical synchronization that corrects for matrix effects, extraction variability, and ionization instability.

## Molecular Identity & Physicochemical Profile

To deploy **Febuxostat-d7** effectively, one must understand its structural relationship to the analyte.

Feature	Febuxostat (Analyte)	Febuxostat-d7 (Internal Standard)
CAS Registry	144060-53-7	1285539-74-3
Formula	C <sub>16</sub> H <sub>16</sub> N <sub>2</sub> O <sub>3</sub> S	C <sub>16</sub> H <sub>9</sub> D <sub>7</sub> N <sub>2</sub> O <sub>3</sub> S
Molecular Weight	316.38 g/mol	~323.42 g/mol
Label Position	N/A	Isobutoxy side chain (typically 2-methylpropoxy-d7)
LogP	~3.2 (Lipophilic)	~3.15 (Slightly lower due to C-D bonds)
pKa	3.3 (Carboxylic acid)	3.3 (Unchanged)

## The Deuterium Isotope Effect

A critical mechanistic nuance is the Deuterium Isotope Effect. Carbon-Deuterium (C-D) bonds are shorter and stronger than Carbon-Hydrogen (C-H) bonds, resulting in a slightly smaller molar volume and lower lipophilicity.

- **Chromatographic Impact:** On Reverse-Phase (C18) columns, **Febuxostat-d7** may elute slightly earlier (0.01–0.05 min) than the unlabeled analyte.
- **Implication:** While they do not co-elute perfectly in ultra-high-resolution chromatography, the overlap is sufficient in standard bioanalytical methods to ensure they experience the same "matrix window."

## Mechanism of Action: The Correction Triad

**Febuxostat-d7** functions through three distinct corrective mechanisms during the LC-MS/MS workflow.

## Extraction Recovery Normalization

During Liquid-Liquid Extraction (LLE) or Protein Precipitation (PPT), physical losses occur. Because **Febuxostat-d7** is chemically identical to the analyte (save for the isotope mass), it partitions into the organic phase (e.g., tert-butyl methyl ether) with the exact same efficiency.

- Mechanism: If extraction recovery drops to 85% due to experimental error, the IS signal drops by the same 85%. The Ratio (Analyte/IS) remains constant.

## Matrix Effect Compensation (Ionization)

This is the primary role of the IS. Co-eluting phospholipids or salts in plasma can suppress Electrospray Ionization (ESI).

- Mechanism: Since **Febuxostat-d7** elutes within the same ionization window as Febuxostat, it suffers the exact same degree of ion suppression.
- Result:  $\frac{\text{Suppressed Analyte Signal}}{\text{Suppressed IS Signal}} = \text{Corrected Ratio}$

## Fragmentation Mechanics (MS/MS)

In Positive Mode ESI, a specific rearrangement occurs that validates the isotopic labeling.

- Analyte (m/z 317): Loses the isobutene group (neutral loss of 56 Da) to form the core fragment (m/z 261).
- IS (m/z 324): The label is on the isobutoxy chain. During fragmentation, a McLafferty-type rearrangement transfers one Deuterium atom to the core structure before the neutral loss of the deuterated alkene.
- The Shift: The fragment ion shifts from 261 (Analyte) to 262 (IS).<sup>[2][3]</sup> This +1 shift proves the transfer of a specific Deuterium, ensuring high specificity and no cross-talk.

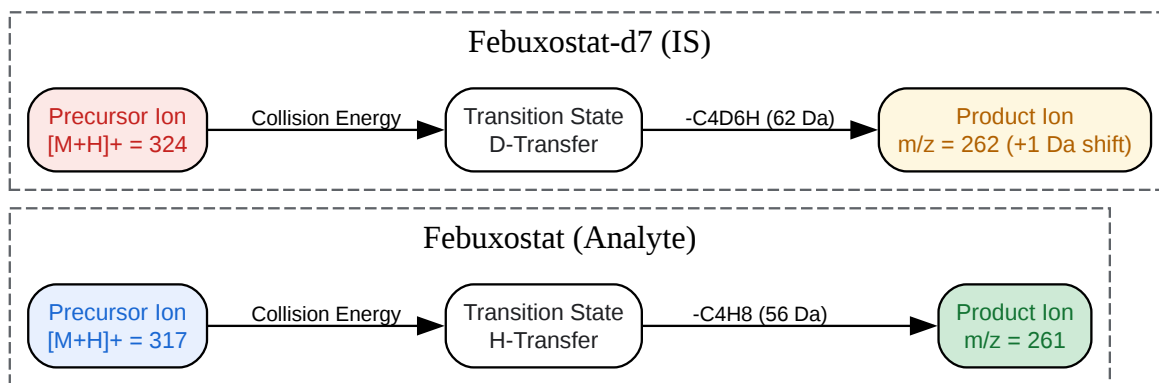

[Click to download full resolution via product page](#)

Figure 1: Proposed fragmentation pathway illustrating the Deuterium transfer that results in the specific  $m/z$  262 product ion for the Internal Standard.

## Experimental Protocol: LC-MS/MS Quantitation

Objective: Quantify Febuxostat in human plasma (1.0 – 6000 ng/mL).

### Reagents & Stock Preparation

- IS Stock: Dissolve **Febuxostat-d7** in DMSO to 1 mg/mL.
- IS Working Solution: Dilute Stock in 50:50 Acetonitrile:Water to ~500 ng/mL. Note: This concentration should yield a signal similar to the mid-level calibration standard.

### Sample Preparation (Liquid-Liquid Extraction)

Rationale: LLE provides cleaner extracts than precipitation, reducing phospholipid buildup on the column.

- Aliquot: Transfer 100  $\mu$ L human plasma to a glass tube.
- Spike: Add 10  $\mu$ L IS Working Solution (**Febuxostat-d7**). Vortex 10s.
- Acidify: Add 50  $\mu$ L 1% Formic Acid (enhances partitioning of the acidic drug).

- Extract: Add 2 mL Methyl tert-butyl ether (MTBE) or Diethyl Ether.
- Agitate: Vortex 5 mins; Centrifuge at 4000 rpm for 5 mins.
- Evaporate: Transfer organic (upper) layer to a clean tube; evaporate to dryness under Nitrogen at 40°C.
- Reconstitute: Dissolve residue in 200 µL Mobile Phase.

## LC-MS/MS Parameters

### Chromatography:

- Column: C18 Reverse Phase (e.g., Zorbax Eclipse XDB or Ascentis Express), 50 x 4.6 mm, 3.5 µm.
- Mobile Phase: Acetonitrile : 5mM Ammonium Formate (60:40 v/v).[3] Isocratic flow ensures stable ionization.
- Flow Rate: 0.5 - 0.8 mL/min.

### Mass Spectrometry (ESI+):

- Source: Electrospray Ionization (Positive Mode). Note: While Febuxostat is acidic, positive mode often yields better sensitivity via the protonated molecular ion [M+H]<sup>+</sup>.
- MRM Transitions:

Compound	Precursor (Q1)	Product (Q3)	Dwell Time	Collision Energy
Febuxostat	317.1	261.1	100 ms	~20-25 eV
Febuxostat-d7	324.2	262.1	100 ms	~20-25 eV

## Validation Strategy: Ensuring IS Integrity

A robust method must validate that the IS is performing correctly and not introducing errors.

## Cross-Talk (Interference) Check

Because the mass difference is only 7 Da, isotopic impurities can cause interference.

- Test: Inject a blank sample containing only **Febuxostat-d7** at the working concentration.
- Acceptance Criteria: The signal in the Analyte channel (317/261) must be < 20% of the Lower Limit of Quantitation (LLOQ).
- Mechanism:<sup>[4]</sup><sup>[5]</sup> If the d7 standard contains d0 impurities, it will falsely elevate analyte concentration.

## Matrix Factor (MF) Assessment

Calculate the Matrix Factor for both Analyte and IS.

- $\text{MF} = \frac{\text{Peak Area in Matrix}}{\text{Peak Area in Neat Solution}}$
- IS-Normalized MF:  $\frac{\text{MF (Analyte)}}{\text{MF (IS)}}$
- Requirement: The IS-Normalized MF should be close to 1.0 (indicating the IS is compensating perfectly) and the CV% across different lots of plasma should be < 15%.

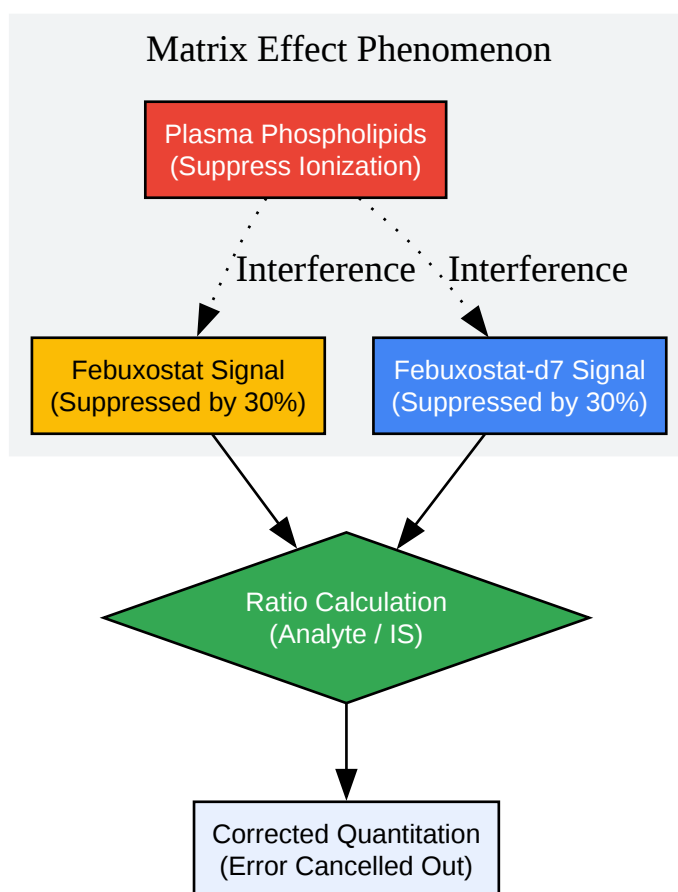

[Click to download full resolution via product page](#)

Figure 2: Logic flow demonstrating how the Internal Standard cancels out matrix-induced ion suppression.

## References

- Pandya, A. et al. (2013).[6] A sensitive LC-MS/MS method for the quantification of febuxostat in human plasma and its pharmacokinetic application. Biomedical Chromatography.
- Saru, B. R. et al. (2024). A Detailed Review on LC-MS Methods for Assessing Febuxostat in Blood Plasma. Pharmaceutical Research.
- Veeprho Laboratories. **Febuxostat-D7** Certificate of Analysis and Structure.
- Waters Corporation. The Use of Stable-Isotope-Labeled (SIL) Internal Standards to Compensate for Matrix Effects.

- Chawla, G. et al. (2013). Bioequivalence and pharmacokinetic study of febuxostat in human plasma by using LC-MS/MS. SpringerPlus.

### Need Custom Synthesis?

BenchChem offers custom synthesis for rare earth carbides and specific isotopic labeling.

Email: [info@benchchem.com](mailto:info@benchchem.com) or [Request Quote Online](#).

## Sources

- 1. Febuxostat-d7 | CAS 1285539-74-3 | LGC Standards [[lgcstandards.com](https://www.lgcstandards.com)]
- 2. Bioequivalence and pharmacokinetic study of febuxostat in human plasma by using LC-MS/MS with liquid liquid extraction method - PMC [[pmc.ncbi.nlm.nih.gov](https://pubmed.ncbi.nlm.nih.gov/)]
- 3. A sensitive LC-MS/MS method for the quantification of febuxostat in human plasma and its pharmacokinetic application - PubMed [[pubmed.ncbi.nlm.nih.gov](https://pubmed.ncbi.nlm.nih.gov/)]
- 4. Investigation of variability in the matrix effect on stable isotope-labeled internal standards in liquid chromatography-tandem mass spectrometry analysis of 25 pesticides in vegetables - PMC [[pmc.ncbi.nlm.nih.gov](https://pubmed.ncbi.nlm.nih.gov/)]
- 5. [chromatographyonline.com](https://www.chromatographyonline.com) [[chromatographyonline.com](https://www.chromatographyonline.com)]
- 6. [openaccesspub.org](https://openaccesspub.org) [[openaccesspub.org](https://openaccesspub.org)]
- To cite this document: BenchChem. [Technical Guide: Febuxostat-d7 in Bioanalytical Quantitation]. BenchChem, [2026]. [Online PDF]. Available at: [<https://www.benchchem.com/product/b585829/docs#technical-guide-febuxostat-d7-in-bioanalytical-quantitation>]

---

### Disclaimer & Data Validity:

The information provided in this document is for Research Use Only (RUO) and is strictly not intended for diagnostic or therapeutic procedures. While BenchChem strives to provide accurate protocols, we make no warranties, express or implied, regarding the fitness of this product for every specific experimental setup.

**Technical Support:** The protocols provided are for reference purposes. Unsure if this reagent suits your experiment?

**Need Industrial/Bulk Grade?** [Request Custom Synthesis Quote](#)

## BenchChem

Our mission is to be the trusted global source of essential and advanced chemicals, empowering scientists and researchers to drive progress in science and industry.

### Contact

Address: 3281 E Guasti Rd  
Ontario, CA 91761, United States  
Phone: (601) 213-4426  
Email: [info@benchchem.com](mailto:info@benchchem.com)

[Contact our Ph.D. Support Team for a compatibility check](#)