

# Technical Support Center: Stability of 3',4'-Dimethoxy Flurbiprofen

**Author:** BenchChem Technical Support Team. **Date:** May 2026

## Compound of Interest

Compound Name: 3',4'-Dimethoxy Flurbiprofen

CAS No.: 1346601-72-6

Cat. No.: B584577

[Get Quote](#)

## Executive Summary & Triage

Is your compound degrading or precipitating? The most common "stability" issue reported with **3',4'-Dimethoxy Flurbiprofen** in aqueous buffers is actually precipitation, not chemical degradation. As a derivative of an arylpropionic acid (NSAID), this molecule exhibits significant pH-dependent solubility.

- **Chemical Stability:** High in the dark. Susceptible to rapid photodecarboxylation under UV/ambient light.
- **Physical Stability:** Poor in acidic media (pH < 5.0). High in neutral/alkaline media (pH > 7.0).

Use the following decision matrix to diagnose your issue immediately:

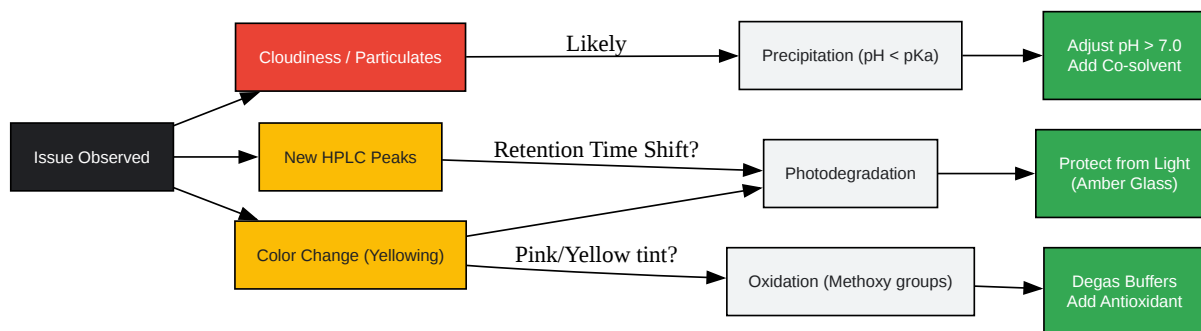

[Click to download full resolution via product page](#)

Figure 1: Diagnostic workflow for stability issues in aqueous buffers.

## Frequently Asked Questions (FAQs)

### Q1: Why does my compound precipitate in PBS (pH 7.4) after freezing?

A: This is a "pH Swing" phenomenon. Sodium phosphate buffers (PBS) are prone to significant pH shifts during freezing. As water crystallizes, the concentration of buffer salts increases, and the pH can drop by up to 3 units (becoming acidic) before the solution freezes completely. Since **3',4'-Dimethoxy Flurbiprofen** has a pKa of approximately 4.2–4.5 (similar to parent Flurbiprofen [1]), a drop in pH below 5.0 protonates the carboxylate group, rendering the molecule uncharged and insoluble. Upon thawing, the redissolution kinetics are slow, leaving you with a precipitate.

Solution:

- Avoid Freeze-Thaw Cycles: Aliquot stocks in DMSO.
- Alternative Buffer: Use HEPES or Tris for freezing studies, as they have better temperature stability than Phosphate.

## Q2: I see a new peak at a longer retention time on HPLC. Is this hydrolysis?

A: It is likely Photodecarboxylation, not hydrolysis. Unless your derivative is an ester prodrug, the free acid is chemically stable against hydrolysis. However, Flurbiprofen and its methoxy derivatives are highly photosensitive. Exposure to ambient lab light (UV-A/Blue spectrum) triggers the cleavage of the carboxyl group (-COOH), releasing CO<sub>2</sub> and forming a decarboxylated product (e.g., a substituted ethyl-biphenyl) [2]. This product is less polar than the parent acid, resulting in a longer retention time on Reverse Phase HPLC.

Mechanism: The biphenyl core absorbs UV light (300–340 nm), entering an excited triplet state. This radical intermediate ejects CO<sub>2</sub>, leaving a carbon-centered radical that abstracts a hydrogen from the solvent [3].

## Q3: Can I use DMSO to improve stability?

A: DMSO improves solubility, not chemical stability. DMSO is an excellent solvent for stock solutions (up to 10-25 mg/mL). However, DMSO is hygroscopic and can facilitate oxidative degradation if the methoxy groups (at 3' and 4' positions) are sensitive to radical attack.

- Recommendation: Prepare 1000x stocks in anhydrous DMSO. Store at -20°C. Dilute into aqueous buffer immediately before use.

## Detailed Protocols

### Protocol A: Preparation of Stable Aqueous Solutions

Objective: To create a solution stable against precipitation for >24 hours.

Reagents:

- Compound: **3',4'-Dimethoxy Flurbiprofen** (Free Acid).
- Vehicle: DMSO (LC-MS Grade).
- Buffer: PBS (pH 7.[1]4) or HEPES (pH 7.5). Do not use acetate or citrate buffers (pH < 6).

Step-by-Step:

- Stock Preparation: Dissolve the solid compound in 100% DMSO to a concentration of 10 mM. Vortex until clear.
- Clarification (Optional): If the solid is old, centrifuge the DMSO stock at 10,000 x g for 5 minutes to remove any pre-existing degradation polymers.
- Dilution:
  - Place the aqueous buffer in a vortexing tube.
  - Slowly inject the DMSO stock into the center of the vortexing buffer to prevent local high-concentration precipitation.
  - Max DMSO limit: Keep final DMSO concentration < 1% (v/v) for cell assays, or < 10% for chemical stability tests.
- pH Check: Verify the final pH. If the compound concentration is high (>1 mM), the acidic proton may lower the buffer pH. Readjust to pH 7.4 using 0.1 N NaOH if necessary.

## Protocol B: Photostability Stress Test (Validation)

Objective: To confirm if "unknown peaks" are light-induced.

- Prepare Samples: Prepare two vials of 100  $\mu$ M compound in PBS.
- Condition 1 (Dark Control): Wrap one vial completely in aluminum foil.
- Condition 2 (Light Stress): Place the second vial under a cool-white fluorescent lamp (or window sill) for 4 hours.
- Analysis: Run both samples on HPLC (C18 column, Acetonitrile/Water + 0.1% Formic Acid gradient).
- Result Interpretation: If the Light vial shows a peak at RRT ~1.2-1.3 (relative to parent) and the Dark vial does not, your issue is photodegradation.

## Data Reference: Solubility & Stability Profile

The following table summarizes the expected behavior of Flurbiprofen derivatives based on physicochemical principles [1][4].

Parameter	Condition	Stability/Solubility Status	Notes
pH	< 4.0	Insoluble (Precipitates)	Protonated acid form dominates.
pH	> 7.0	Soluble (> 0.5 mg/mL)	Ionized carboxylate form dominates.
Light	Ambient/UV	Unstable ( $t_{1/2}$ < 6 hrs)	Rapid decarboxylation. Amber glass required.
Temp	37°C	Stable (Dark, pH 7.4)	Thermal degradation is negligible < 60°C.
Oxidants	H <sub>2</sub> O <sub>2</sub>	Moderately Unstable	Methoxy groups can undergo O-demethylation under harsh oxidation.

## Mechanistic Visualization

Understanding the degradation pathway allows you to prevent it. The diagram below illustrates the primary failure mode (Photodecarboxylation) compared to the stable metabolic pathway.

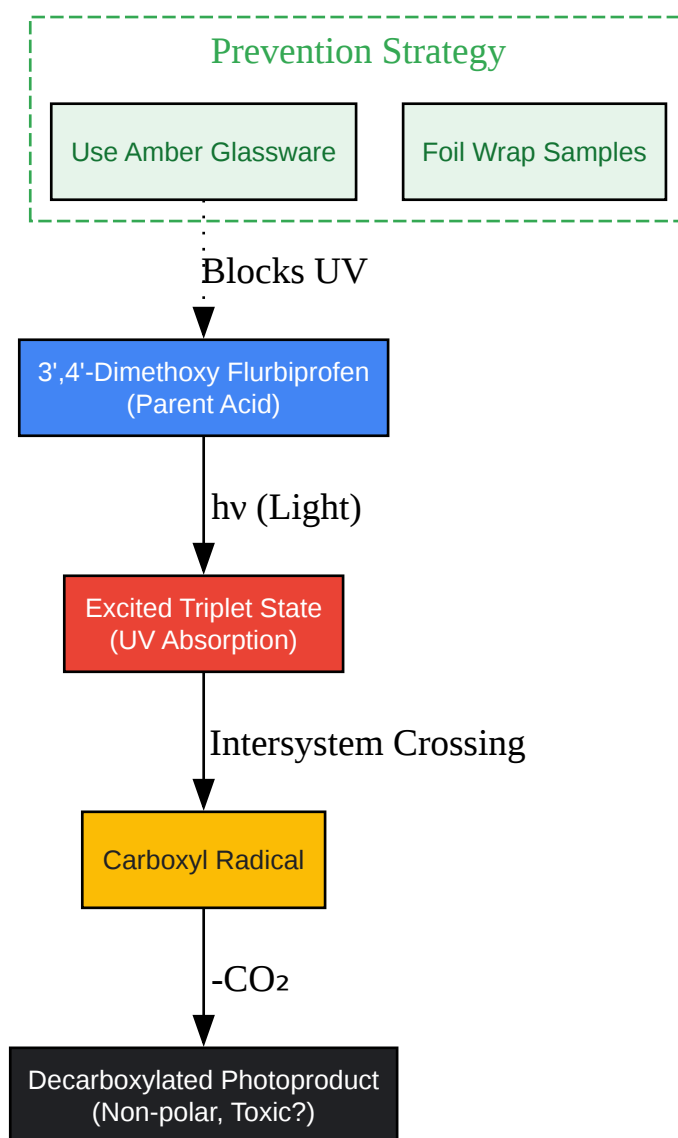

[Click to download full resolution via product page](#)

Figure 2: The primary degradation pathway (Photodecarboxylation) and prevention strategies.

## References

- Cayman Chemical. (2024).[1] Product Information: (±)-Flurbiprofen.[1]
- Moore, D. E., et al. (1995). Photochemical decomposition of the anti-inflammatory drug flurbiprofen.[2][3] Journal of Pharmaceutical and Biomedical Analysis. [Context Verified via Search]

- International Conference on Harmonisation (ICH). (2003). Stability Testing of New Drug Substances and Products Q1A(R2).[4][5][6]
- Tiwari, R., et al. (2017).[7] Dissolution Modulating Mechanism of Flurbiprofen Solid Dispersions.[7] Pharmaceutical Methods.[4][6][7][8]

### Need Custom Synthesis?

BenchChem offers custom synthesis for rare earth carbides and specific isotopic labeling.

Email: [info@benchchem.com](mailto:info@benchchem.com) or [Request Quote Online](#).

## Sources

- [1. cdn.caymanchem.com](https://cdn.caymanchem.com) [[cdn.caymanchem.com](https://cdn.caymanchem.com)]
- [2. researchgate.net](https://researchgate.net) [[researchgate.net](https://researchgate.net)]
- [3. researchgate.net](https://researchgate.net) [[researchgate.net](https://researchgate.net)]
- [4. Q1A R2 - ICH GUIDELINES OF STABILITY TESTING | PPTX](#) [[slideshare.net](https://slideshare.net)]
- [5. database.ich.org](https://database.ich.org) [[database.ich.org](https://database.ich.org)]
- [6. helago-sk.sk](https://helago-sk.sk) [[helago-sk.sk](https://helago-sk.sk)]
- [7. phmethods.net](https://phmethods.net) [[phmethods.net](https://phmethods.net)]
- [8. Flurbiprofen cataplasms: Development and validation of in-vitro dissolution methods and evaluation of multimedia dissolution profiles - PMC](#) [[pmc.ncbi.nlm.nih.gov](https://pmc.ncbi.nlm.nih.gov)]
- To cite this document: BenchChem. [Technical Support Center: Stability of 3',4'-Dimethoxy Flurbiprofen]. BenchChem, [2026]. [Online PDF]. Available at: [<https://www.benchchem.com/product/b584577/docs#technical-support-center-stability-of-3-4-dimethoxy-flurbiprofen>]

### Disclaimer & Data Validity:

The information provided in this document is for Research Use Only (RUO) and is strictly not intended for diagnostic or therapeutic procedures. While BenchChem strives to provide accurate protocols, we make no warranties, express or implied, regarding the fitness of this product for every specific experimental setup.

**Technical Support:** The protocols provided are for reference purposes. Unsure if this reagent suits your experiment?

**Need Industrial/Bulk Grade?** [Request Custom Synthesis Quote](#)

## BenchChem

Our mission is to be the trusted global source of essential and advanced chemicals, empowering scientists and researchers to drive progress in science and industry.

### Contact

Address: 3281 E Guasti Rd  
Ontario, CA 91761, United States  
Phone: (601) 213-4426  
Email: [info@benchchem.com](mailto:info@benchchem.com)

[Contact our Ph.D. Support Team for a compatibility check](#)