

Technical Support Center: Direct ^{15}N Detection Protocols

Author: BenchChem Technical Support Team. **Date:** May 2026

Compound of Interest

Compound Name: Ammonium- ^{15}N bromide

CAS No.: 39466-31-4

Cat. No.: B584713

[Get Quote](#)

Topic: Overcoming Sensitivity Limitations in Direct ^{15}N NMR Spectroscopy Ticket ID: NMR- ^{15}N -SENS-001 Status: Open Responder: Senior Application Scientist, Bio-NMR Division

Executive Summary: The "Sensitivity Cliff"

Direct ^{15}N detection (acquiring the FID on the nitrogen channel) is inherently challenging due to the low gyromagnetic ratio of nitrogen (

), which is roughly 1/10th that of protons. Since sensitivity scales roughly with

, direct ^{15}N experiments are theoretically ~300-1,000 times less sensitive than ^1H experiments.

However, direct ^{15}N detection is critical for:

- Proline-rich motifs (which lack amide protons).
- Intrinsically Disordered Proteins (IDPs) (where ^1H dispersion is poor).
- Paramagnetic systems (where ^1H signals are broadened beyond detection).

This guide provides a systematic workflow to recover sensitivity through hardware optimization, polarization transfer, and relaxation engineering.

Diagnostic & Troubleshooting Modules

Module A: Hardware & Configuration

Symptom: "I am running a standard zg (1D) or hsqc sequence and seeing nothing but noise."

Checkpoint	Technical Reality	Action Item
Probe Geometry	Standard "Inverse" probes place the 1H coil closest to the sample (inner) and the X-nucleus (15N) coil outer. This causes significant signal loss for direct X-detection.	Switch to a Direct/Observe Probe: Ensure you are using a BBO (Broadband Observe) or a CryoProbe™ optimized for 15N/13C (e.g., a "Nitrogen CryoProbe") where the inner coil is tuned to 15N.
Filling Factor	15N sensitivity is volume-critical.	Shigemi Tubes: If sample volume is limited (<300µL), use susceptibility-matched Shigemi tubes to maximize the filling factor within the active coil volume.
Temperature	Lower temperatures improve Boltzmann distribution but broaden lines (viscosity).	Optimize T: For small molecules, lower T (e.g., 280K) boosts signal. For proteins, higher T (e.g., 310K) narrows linewidths, improving Signal-to-Noise (SNR).

Module B: Pulse Sequence Strategy (The "Physics" Fix)

Symptom: "My 1D 15N takes 12 hours. How do I speed this up?"

The Solution: Polarization Transfer (INEPT) Do not use a simple pulse-acquire (zg) sequence unless you lack protons entirely. You must exploit the reservoir of proton magnetization.

Protocol 1: Refocused INEPT for 1D 15N

Instead of exciting 15N directly, we excite 1H, transfer polarization to 15N via

-coupling (

Hz), and detect on 15N.

- Gain: Theoretical enhancement of

.

- Sequence: `ineptrd` (Bruker) or equivalent.

- Parameter Criticality: The delay

must be precise. For backbone amides, set

ms.

Protocol 2: Handling the Negative NOE

If you must use direct excitation (e.g., no protons nearby), you might rely on the Nuclear Overhauser Effect (NOE) during decoupling.

- Risk: 15N has a negative NOE. Continuous proton decoupling during the relaxation delay can create a signal of intensity

. Since

, the signal can null itself or become negative.

- Fix: Use Inverse Gated Decoupling (`zgig`).
 - Decoupler ON during acquisition (to collapse J-couplings).
 - Decoupler OFF during relaxation delay (to avoid building up negative NOE).

Module C: Sample Chemistry (The "Chemist's Hack")

Symptom: "I have high concentration (100 mM) but the scan is still slow because

is 5 seconds."

The Solution: Paramagnetic Relaxation Enhancement (PRE) Nitrogen-15 has a very long longitudinal relaxation time (

), often 2–10 seconds. This forces long inter-scan delays (

), making signal averaging painfully slow.

- Method: Doping with a paramagnetic relaxation agent.
- Agent: Chromium(III) acetylacetonate [Cr(acac)₃] (organic solvents) or Gd-DTPA (aqueous).
- Mechanism: The unpaired electrons provide a potent relaxation pathway, reducing from seconds to milliseconds.
- Result: You can reduce the relaxation delay () from 10s to 0.5s, allowing 20x more scans in the same timeframe.

Decision Logic & Workflows

Workflow 1: Pulse Sequence Selection

Use this logic gate to select the correct acquisition strategy based on your sample's protonation state.

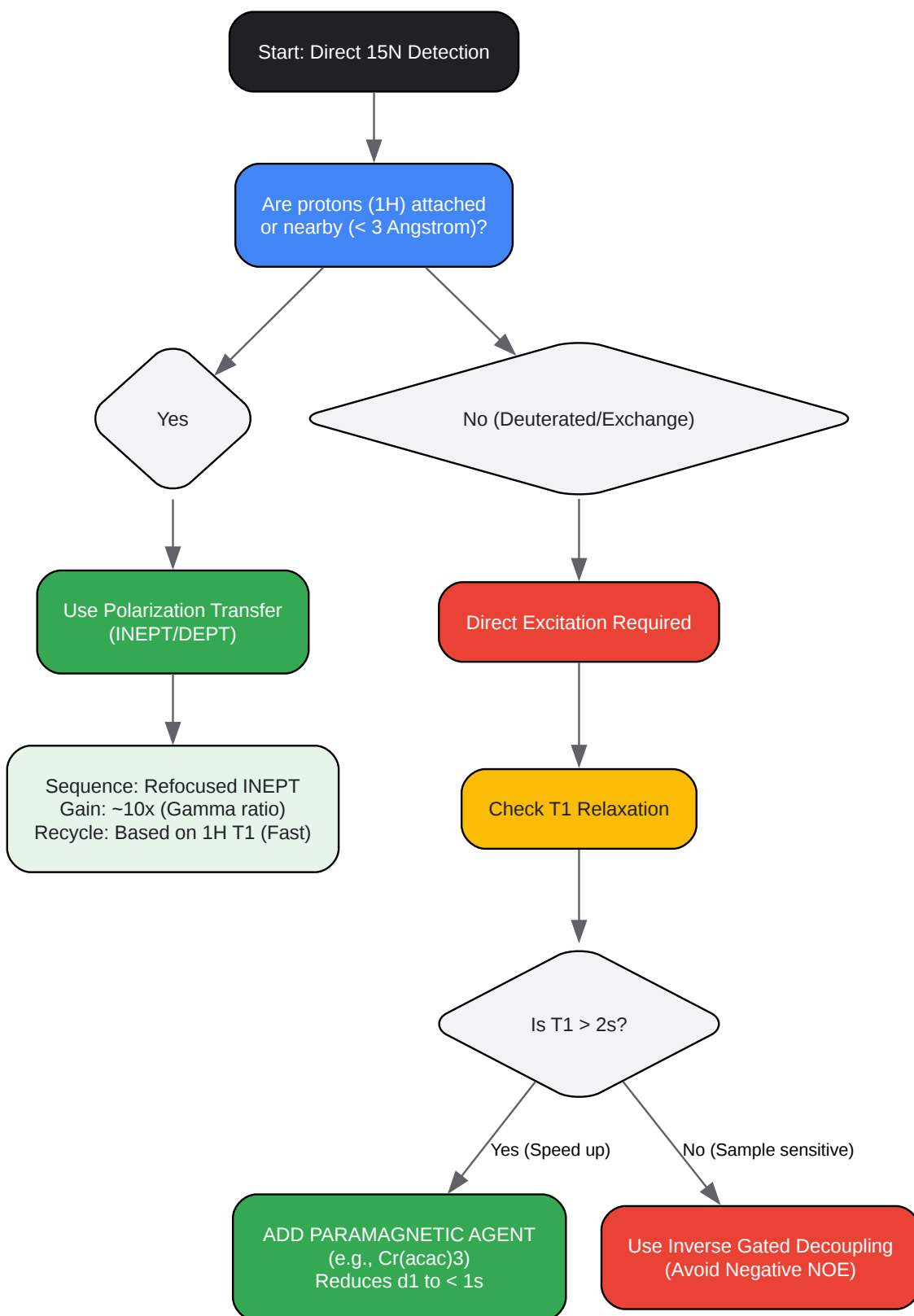

[Click to download full resolution via product page](#)

Caption: Decision matrix for selecting the optimal ^{15}N detection pulse sequence based on proton availability and relaxation constraints.

Workflow 2: The "Sensitivity Trinity"

Optimizing these three pillars simultaneously is required for maximum SNR.

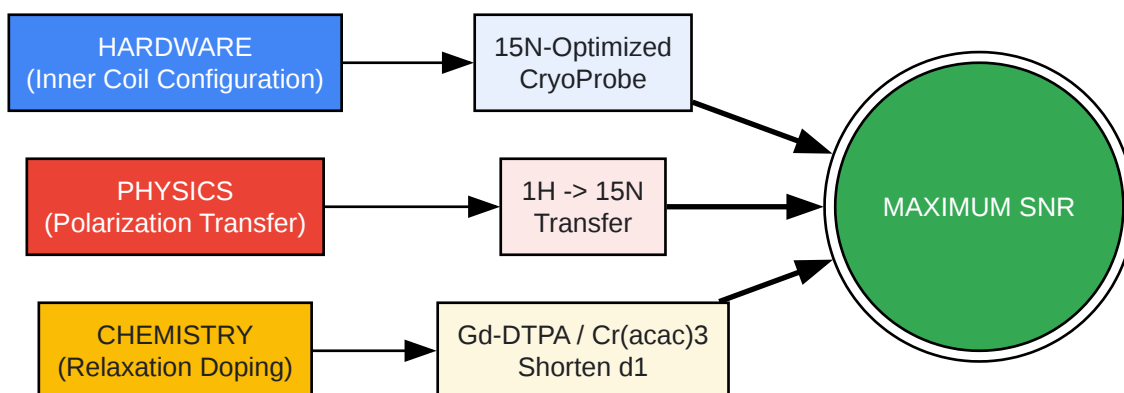

[Click to download full resolution via product page](#)

Caption: The three pillars of sensitivity enhancement. Neglecting one pillar can compromise the entire experiment.

Frequently Asked Questions (FAQ)

Q1: Why is my signal negative when I turn on decoupling? A: This is the Nuclear Overhauser Effect (NOE) in action. For ^{15}N , the gyromagnetic ratio is negative, leading to a negative NOE enhancement factor (

).

If you use continuous broadband decoupling, the NOE builds up and opposes your thermal magnetization.

- Fix: Use Inverse Gated Decoupling. This limits decoupling only to the acquisition time (to collapse J-couplings) while keeping the decoupler OFF during the relaxation delay to prevent NOE buildup.

Q2: Can I use SOFAST-HMQC for direct ^{15}N detection? A: Technically, no. SOFAST (Band-Selective Optimized Flip-Angle Short-Transient) is primarily a proton-detected experiment designed to speed up 2D acquisition by selectively exciting amide protons.

- Alternative: For direct ^{15}N detection, the equivalent logic (fast repetition) is achieved by doping the sample with paramagnetic agents (see Module C), which allows you to pulse faster without saturating the signal.

Q3: Is a CryoProbe worth it for ^{15}N ? A: Yes, but check the configuration. A standard "Inverse" CryoProbe (optimized for ^1H) offers only a modest gain for ^{15}N direct detection. You need a ^{15}N -optimized CryoProbe (often called a "Carbon/Nitrogen CryoProbe") where the pre-amplifier and cold coil are dedicated to the X-channel. This can yield a factor of 3–4x in SNR compared to a room-temperature probe, which is equivalent to reducing experimental time by a factor of ~16.

References

- Morris, G. A., & Freeman, R. (1979). Enhancement of nuclear magnetic resonance signals by polarization transfer. *Journal of the American Chemical Society*, 101(3), 760–762. [Link](#)
- Bermel, W., Bertini, I., Felli, I. C., Piccioli, M., & Pierattelli, R. (2006). ^{13}C -detected protonless NMR spectroscopy of proteins in solution. *Progress in Nuclear Magnetic Resonance Spectroscopy*, 48(1), 25-45. [Link](#)
- Takeuchi, K., & Wagner, G. (2006). NMR studies of protein structure and dynamics with direct detection of ^{13}C and ^{15}N signals. *Current Opinion in Structural Biology*, 16(5), 623-629. [Link](#)
- Cavanagh, J., Fairbrother, W. J., Palmer III, A. G., Rance, M., & Skelton, N. J. (2007). *Protein NMR Spectroscopy: Principles and Practice* (2nd ed.). Academic Press. [Link](#)
- To cite this document: BenchChem. [Technical Support Center: Direct ^{15}N Detection Protocols]. BenchChem, [2026]. [Online PDF]. Available at: [\[https://www.benchchem.com/product/b584713/docs#technical-support-center-direct-15n-detection-protocols\]](https://www.benchchem.com/product/b584713/docs#technical-support-center-direct-15n-detection-protocols)

Disclaimer & Data Validity:

The information provided in this document is for Research Use Only (RUO) and is strictly not intended for diagnostic or therapeutic procedures. While BenchChem strives to provide

accurate protocols, we make no warranties, express or implied, regarding the fitness of this product for every specific experimental setup.

Technical Support: The protocols provided are for reference purposes. Unsure if this reagent suits your experiment?

Need Industrial/Bulk Grade? [Request Custom Synthesis Quote](#)

BenchChem

Our mission is to be the trusted global source of essential and advanced chemicals, empowering scientists and researchers to drive progress in science and industry.

Contact

Address: 3281 E Guasti Rd

Ontario, CA 91761, United States

Phone: (601) 213-4426

Email: info@benchchem.com

[Contact our Ph.D. Support Team for a compatibility check](#)