

Technical Support Center: 7-Methoxy-1-naphthaldehyde-d3 Assays

Author: BenchChem Technical Support Team. **Date:** May 2026

Compound of Interest

Compound Name: 7-Methoxy-1-naphthaldehyde-d3

CAS No.: 1346604-99-6

Cat. No.: B584897

[Get Quote](#)

Welcome to the technical support center for assays utilizing **7-Methoxy-1-naphthaldehyde-d3**. This guide is designed for researchers, scientists, and drug development professionals to provide in-depth troubleshooting advice and answers to frequently asked questions. Our goal is to empower you with the scientific rationale behind experimental protocols, ensuring the integrity and success of your research.

Introduction to 7-Methoxy-1-naphthaldehyde-d3

7-Methoxy-1-naphthaldehyde is a highly fluorogenic aldehyde that serves as a key indicator for the activity of aldehyde dehydrogenase (ALDH) in various biological samples.[1] The deuterated version, **7-Methoxy-1-naphthaldehyde-d3**, is an invaluable tool in quantitative bioanalytical assays, particularly those employing liquid chromatography-mass spectrometry (LC-MS). It functions as a stable isotope-labeled internal standard (SIL-IS), which is crucial for correcting variations during sample preparation and analysis, thereby enhancing the accuracy and precision of quantification.[2][3]

While SIL-IS are the gold standard, their use is not without potential pitfalls. This guide will address common sources of interference and provide systematic approaches to

troubleshooting your **7-Methoxy-1-naphthaldehyde-d3** based assays.

Frequently Asked Questions (FAQs)

Q1: What is the primary application of **7-Methoxy-1-naphthaldehyde-d3**?

A1: **7-Methoxy-1-naphthaldehyde-d3** is primarily used as an internal standard in quantitative bioanalytical methods, such as LC-MS/MS, to measure the corresponding non-deuterated analyte, 7-Methoxy-1-naphthaldehyde. The analyte itself is often used as a probe to measure the activity of enzymes like aldehyde dehydrogenase (ALDH).[1] The use of a deuterated internal standard is critical for correcting for sample loss during extraction, variations in instrument response, and matrix effects.[3][4]

Q2: Can the deuterium atoms on **7-Methoxy-1-naphthaldehyde-d3** exchange with hydrogen atoms from the solvent?

A2: Yes, there is a potential for hydrogen-deuterium (H/D) exchange, which can compromise the accuracy of your results. The deuterium atoms on the methoxy group are generally stable. However, the aldehyde proton is adjacent to a carbonyl group, making it susceptible to enolization and subsequent exchange with protons from the solvent, especially under acidic or basic conditions.[5][6] It is crucial to control the pH of your samples and mobile phases to minimize this exchange.[7]

Q3: How should I properly store my **7-Methoxy-1-naphthaldehyde-d3** stock and working solutions?

A3: Aldehydes can be susceptible to oxidation and degradation. Stock solutions should be stored at -20°C or lower in a tightly sealed container, protected from light. For working solutions, especially in biological matrices, it is advisable to prepare them fresh or conduct stability studies to determine their viability over time at different storage temperatures (e.g., room temperature, 4°C, -20°C, and -80°C).[8] The stability of the derivatized products should also be considered, as some may degrade significantly even after one month of storage at -20°C.[8]

Q4: What level of isotopic purity should I expect for my **7-Methoxy-1-naphthaldehyde-d3** internal standard?

A4: For reliable results, deuterated standards should have high isotopic enrichment (ideally $\geq 98\%$) and high chemical purity ($>99\%$).^[4] The presence of the non-deuterated analyte as an impurity in the internal standard can lead to a positive bias, particularly at the lower limit of quantification (LLOQ).^[9]

Troubleshooting Guide

Issue 1: Non-Linear Calibration Curve, Especially at Low Concentrations

Potential Cause: Presence of unlabeled analyte (7-Methoxy-1-naphthaldehyde) as an impurity in the deuterated internal standard stock. This contributes to the analyte signal, causing a positive bias at lower concentrations.^[9]

Troubleshooting Steps:

- Assess Isotopic Purity:
 - Prepare a "blank" sample containing only the internal standard at the concentration used in your assay.
 - Analyze this sample using your LC-MS/MS method.
 - If a significant signal is observed in the analyte's multiple reaction monitoring (MRM) transition, this confirms the presence of the unlabeled analyte as an impurity.^[9]
- Adjust the Lower Limit of Quantification (LLOQ):
 - If a purer standard is not available, you may need to raise your LLOQ to a concentration where the contribution from the impurity is negligible (typically less than 20% of the LLOQ response).^[9]
- Source a Higher Purity Standard:
 - Contact your supplier to obtain a standard with higher isotopic enrichment.

Issue 2: Inaccurate or Imprecise Results (High Variability)

Potential Cause A: Matrix Effects

Matrix effects, caused by co-eluting endogenous or exogenous components in the biological sample, can lead to ion suppression or enhancement, affecting the analyte and/or internal standard differently.[\[10\]](#)[\[11\]](#)

Troubleshooting Workflow for Matrix Effects:

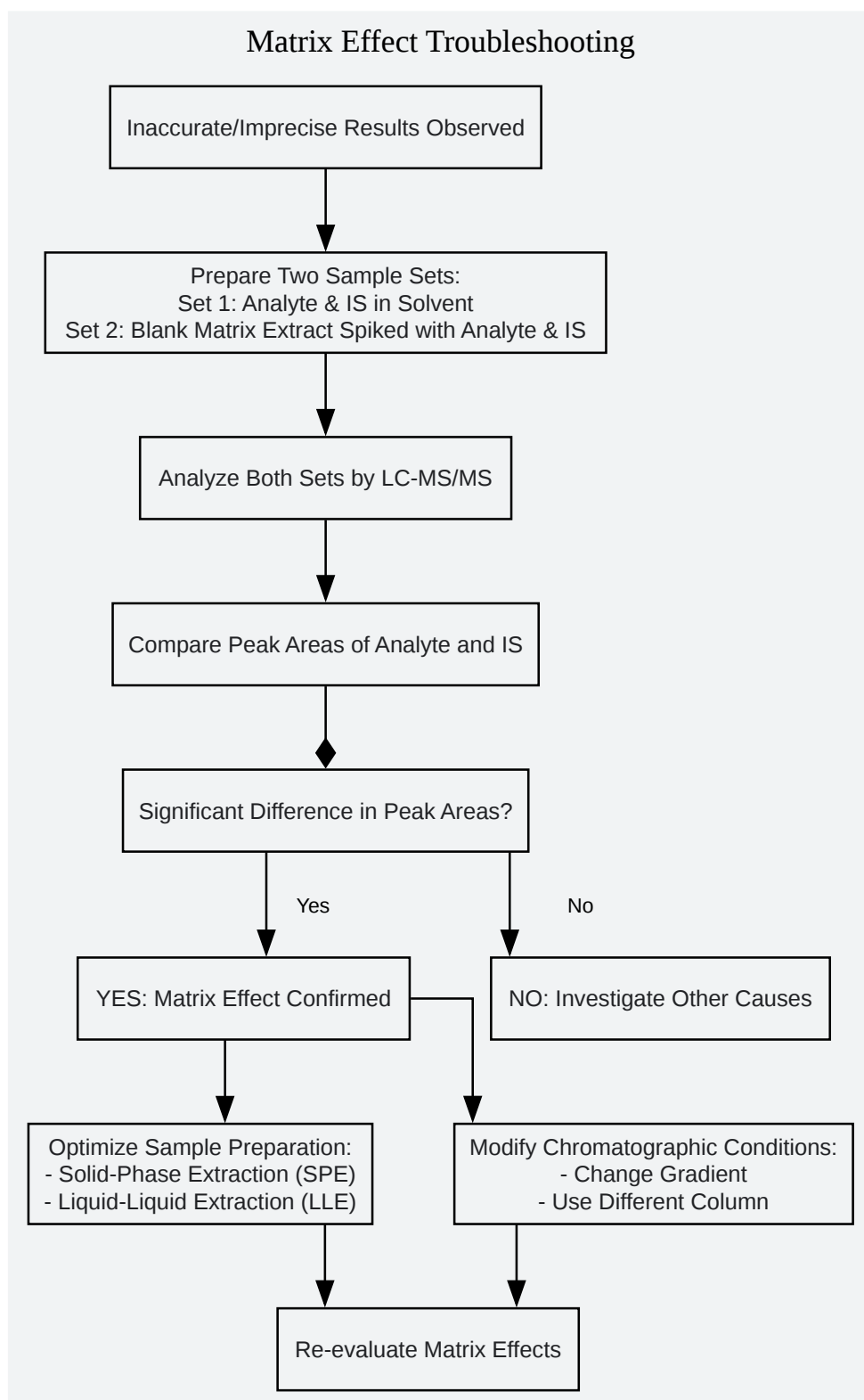

[Click to download full resolution via product page](#)

Caption: Workflow to diagnose and mitigate matrix effects.

Potential Cause B: Hydrogen-Deuterium (H/D) Exchange

As mentioned in the FAQs, the aldehyde proton in 7-Methoxy-1-naphthaldehyde is susceptible to exchange.

Troubleshooting Steps:

- **pH Control:** Maintain a neutral or slightly acidic pH (around 5-6) in your sample and mobile phase to minimize base-catalyzed exchange.[\[12\]](#) Avoid strongly acidic or basic conditions.
- **Solvent Selection:** If possible, use a non-aqueous mobile phase for chromatography.[\[9\]](#)
- **Temperature Control:** Keep sample preparation and storage temperatures as low as possible to reduce the rate of exchange.
- **Alternative Standard:** If the issue persists, consider sourcing a standard with deuterium labels on more stable positions, such as the naphthalene ring.[\[9\]](#)

Potential Cause C: Instability of the Analyte or Internal Standard

Aldehydes can be reactive and may degrade during sample processing or storage.

Troubleshooting Steps:

- **Conduct Stability Studies:** Evaluate the stability of 7-Methoxy-1-naphthaldehyde and its deuterated analog in the biological matrix at various temperatures and for different durations.[\[8\]](#)
- **Use of Antioxidants:** Consider adding a small amount of an antioxidant, such as butylated hydroxytoluene (BHT), to your samples to prevent oxidative degradation.
- **Minimize Freeze-Thaw Cycles:** Aliquot samples to avoid repeated freezing and thawing.

Issue 3: Interference from Naturally Occurring Isotopes

Potential Cause: With a d₃-labeled standard, there is a risk of interference from the naturally occurring isotopes of the analyte.[\[13\]](#) For example, the M+3 isotope of 7-Methoxy-1-

naphthaldehyde, resulting from the presence of three ^{13}C atoms or other combinations of heavy isotopes, can have a similar mass-to-charge ratio as the d3-internal standard.[14]

Troubleshooting Steps:

- **Analyze Mass Spectra:** Carefully examine the mass spectra of both the analyte and the internal standard to assess the extent of isotopic overlap.[14]
- **Optimize Internal Standard Concentration:** Ensure that the concentration of the internal standard is appropriate to minimize the relative contribution of the analyte's isotopic signal. [14]
- **Use a More Heavily Labeled Standard:** If significant interference is observed, consider using an internal standard with a higher degree of deuteration (e.g., d5 or d7) to shift its mass further from the analyte's isotopic envelope.[15]

Experimental Protocols

Protocol 1: Assessment of Matrix Effects

This protocol allows for the quantitative evaluation of matrix effects.

- Prepare three sets of samples:
 - **Set A (Neat Solution):** Prepare standards at low and high concentrations of the analyte and a constant concentration of the internal standard in the initial mobile phase solvent.
 - **Set B (Post-Extraction Spike):** Extract at least six different lots of blank biological matrix. Spike the extracted matrix with the analyte at low and high concentrations and the internal standard at a constant concentration.
 - **Set C (Pre-Extraction Spike):** Spike the blank biological matrix with the analyte at low and high concentrations and the internal standard at a constant concentration before extraction.
- Analyze all samples using the developed LC-MS/MS method.
- Calculate the Matrix Factor (MF):

- $MF = (\text{Peak response in the presence of matrix}) / (\text{Peak response in neat solution})$
- An MF of 1 indicates no matrix effect, <1 indicates ion suppression, and >1 indicates ion enhancement.
- Calculate the Internal Standard Normalized Matrix Factor (IS-Normalized MF):
 - $IS\text{-Normalized MF} = (\text{MF of analyte}) / (\text{MF of internal standard})$
 - The coefficient of variation (CV) of the IS-Normalized MF across the different matrix lots should be less than 15%.

Parameter	Calculation	Acceptance Criteria
Matrix Factor (MF)	$(\text{Peak Area of Post-Extraction Spike}) / (\text{Peak Area of Neat Solution})$	Varies; informs on suppression/enhancement
IS-Normalized MF	$(\text{MF of Analyte}) / (\text{MF of Internal Standard})$	CV < 15%

Visualization of Key Concepts

Interference Pathways in d3-Labeled Standard Assays

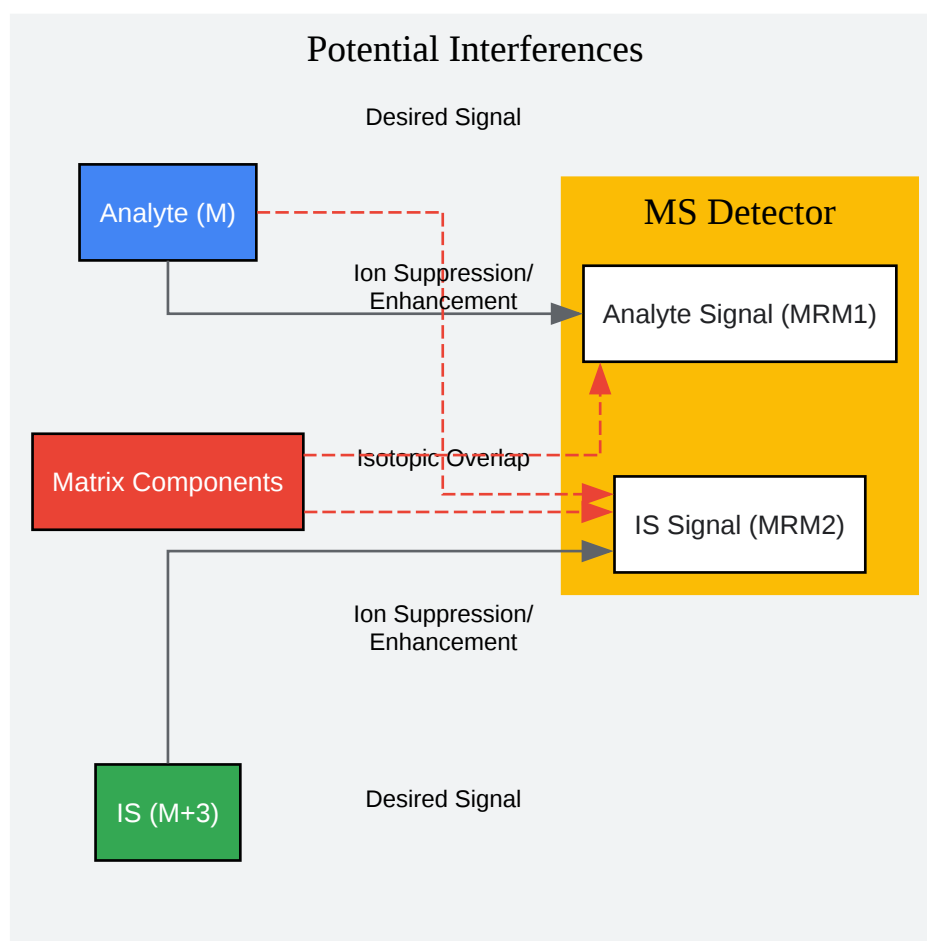

[Click to download full resolution via product page](#)

Caption: Potential sources of interference in assays using d₃-labeled internal standards.

Conclusion

The successful implementation of assays using **7-Methoxy-1-naphthaldehyde-d₃** requires a thorough understanding of the potential sources of interference. By systematically addressing issues such as isotopic purity, H/D exchange, and matrix effects, researchers can develop robust and reliable methods. This guide provides a framework for troubleshooting and optimizing your experiments, ensuring the generation of high-quality, reproducible data.

References

- Duxbury, K. J., et al. (2008). Naturally occurring isotopes of an analyte can interfere with doubly deuterated internal standard measurement. *Annals of Clinical Biochemistry*, 45(Pt 2),

208-10. [\[Link\]](#)

- ResolveMass Laboratories Inc. (2025). Deuterated Internal Standards for LC-MS: Selection & Custom Synthesis. [\[Link\]](#)
- ResolveMass Laboratories Inc. (2025). Deuterated Standards for LC-MS Analysis. [\[Link\]](#)
- KCAS Bio. (2017). The Value of Deuterated Internal Standards. [\[Link\]](#)
- Jurutka, P. W., et al. (2022). Stability of sample extracts of vitamin D3 metabolites after chemical derivatization for LC–MS/MS analysis. *Scientific Reports*, 12(1), 18863. [\[Link\]](#)
- Mei, H., et al. (2002). Investigation of matrix effects in bioanalytical high-performance liquid chromatography/tandem mass spectrometric assays: application to drug discovery. *Rapid Communications in Mass Spectrometry*, 16(18), 1745-51. [\[Link\]](#)
- Zhang, Z., et al. (2019). Practical Synthesis of C-1 Deuterated Aldehydes Enabled by NHC Catalysis. *Nature Communications*, 10(1), 541. [\[Link\]](#)
- Grocholska, P., & Baçhor, R. (2021). Trends in the Hydrogen–Deuterium Exchange at the Carbon Centers. Preparation of Internal Standards for Quantitative Analysis by LC-MS. *Molecules*, 26(10), 2895. [\[Link\]](#)
- Davison, A. S., et al. (2013). Potential problems with using deuterated internal standards for liquid chromatography-tandem mass spectrometry. *Annals of Clinical Biochemistry*, 50(Pt 3), 274. [\[Link\]](#)
- Davison, A. S., et al. (2013). Potential problems with using deuterated internal standards for liquid chromatography-tandem mass spectrometry. *Annals of Clinical Biochemistry*, 50(Pt 3), 274. [\[Link\]](#)
- Chen, L., et al. (2024). Matrix effect in bioanalytical assay development using supercritical fluid chromatography-mass spectrometry. *Biomedical Chromatography*, 38(3), e5759. [\[Link\]](#)
- Modhave, Y. (2012). Matrix Effect in Bioanalysis: An Overview. *International Journal of Pharmaceutical and Phytopharmacological Research*, 1(6), 403-405. [\[Link\]](#)

- Dr. B. (2024). CHEM 2325 Module 27: Alpha Substitution Reactions - Deuterium Exchange. YouTube. [\[Link\]](#)
- Kruszyna, M., et al. (2018). Quantitative evaluation of the matrix effect in bioanalytical methods based on LC-MS: A comparison of two approaches. *Journal of Pharmaceutical and Biomedical Analysis*, 155, 314-319. [\[Link\]](#)
- International Journal of Pharmaceutical and Phytopharmacological Research. (n.d.). matrix-effect-in-bioanalysis-an-overview.pdf. [\[Link\]](#)
- Pharmaffiliates. (n.d.). **7-Methoxy-1-naphthaldehyde-d3**. [\[Link\]](#)
- Wuts, P. G., et al. (2013). Synthesis of Deuterated Enaminones with High Isotopic Fidelity. *ACS Medicinal Chemistry Letters*, 4(12), 1144-1147. [\[Link\]](#)
- Google Patents. (n.d.).
- Caravan, P., et al. (2022). Tailored chemical reactivity probes for systemic imaging of aldehydes in fibroproliferative diseases. *Nature Communications*, 13(1), 7480. [\[Link\]](#)
- Ismail, A. A. (2012). Interferences in Immunoassay. *Clinical Biochemistry*, 45(18), 1333-1348. [\[Link\]](#)
- Fu, L., et al. (2019). Challenges and Opportunities for Small-Molecule Fluorescent Probes in Redox Biology Applications. *Antioxidants & Redox Signaling*, 30(5), 789-813. [\[Link\]](#)
- ResearchGate. (2025). Tailored Chemical Reactivity Probes for Systemic Imaging of Aldehydes in Fibroproliferative Diseases | Request PDF. [\[Link\]](#)
- Kalgutkar, A. S., et al. (2012). Metabolism-guided drug design. *MedChemComm*, 3(9), 1079-1094. [\[Link\]](#)
- ResearchGate. (2021). (PDF) Trends in the Hydrogen–Deuterium Exchange at the Carbon Centers. Preparation of Internal Standards for Quantitative Analysis by LC-MS. [\[Link\]](#)
- Roškar, R., et al. (2021). Comprehensive Stability Study of Vitamin D3 in Aqueous Solutions and Liquid Commercial Products. *Pharmaceutics*, 13(5), 589. [\[Link\]](#)

- Raj, M., et al. (2024). Tunable fluorescent probes for detecting aldehydes in living systems. *Chemical Science*, 15(1), 107-115. [[Link](#)]
- Ide, H., et al. (2001). Quantitation of DNA damage by an aldehyde reactive probe (ARP). *Nucleic Acids Research Supplement*, (1), 45-6. [[Link](#)]
- International Journal of Pharmaceutical Sciences Review and Research. (2025). The Study of Insilco Design and Biological Evaluation of Naphthalene Derivatives. [[Link](#)]
- ResearchGate. (n.d.). Detection and phase I metabolism of the 7-azaindole-derived synthetic cannabinoid 5F-AB-P7AICA including a preliminary pharmacokinetic evaluation | Request PDF. [[Link](#)]
- ResearchGate. (2020). THE EFFECTIVE APPLICATION OF METABOLITE PROFILING IN DRUG DESIGN AND DISCOVERY | Request PDF. [[Link](#)]

Need Custom Synthesis?

BenchChem offers custom synthesis for rare earth carbides and specific isotopic labeling.

Email: info@benchchem.com or [Request Quote Online](#).

Sources

- [1. pharmaffiliates.com](https://pharmaffiliates.com) [pharmaffiliates.com]
- [2. Optimizing Laboratory-Developed LC-MS/MS Tests: Proper Use of Internal Standards - Insights from Two Troubleshooting Case Studies](https://labroots.com) [labroots.com]
- [3. resolvemass.ca](https://resolvemass.ca) [resolvemass.ca]
- [4. resolvemass.ca](https://resolvemass.ca) [resolvemass.ca]
- [5. mdpi.com](https://mdpi.com) [mdpi.com]
- [6. m.youtube.com](https://m.youtube.com) [m.youtube.com]
- [7. researchgate.net](https://researchgate.net) [researchgate.net]
- [8. Stability of sample extracts of vitamin D3 metabolites after chemical derivatization for LC-MS/MS analysis - PMC](https://pubmed.ncbi.nlm.nih.gov) [[pmc.ncbi.nlm.nih.gov](https://pubmed.ncbi.nlm.nih.gov)]
- [9. benchchem.com](https://benchchem.com) [benchchem.com]

- [10. Investigation of matrix effects in bioanalytical high-performance liquid chromatography/tandem mass spectrometric assays: application to drug discovery - PubMed \[pubmed.ncbi.nlm.nih.gov\]](#)
- [11. Matrix effect in bioanalytical assay development using supercritical fluid chromatography-mass spectrometry - PubMed \[pubmed.ncbi.nlm.nih.gov\]](#)
- [12. Comprehensive Stability Study of Vitamin D3 in Aqueous Solutions and Liquid Commercial Products - PMC \[pmc.ncbi.nlm.nih.gov\]](#)
- [13. benchchem.com \[benchchem.com\]](#)
- [14. Naturally occurring isotopes of an analyte can interfere with doubly deuterated internal standard measurement - PubMed \[pubmed.ncbi.nlm.nih.gov\]](#)
- [15. researchgate.net \[researchgate.net\]](#)
- To cite this document: BenchChem. [Technical Support Center: 7-Methoxy-1-naphthaldehyde-d3 Assays]. BenchChem, [2026]. [Online PDF]. Available at: [\[https://www.benchchem.com/product/b584897/docs#technical-support-center-7-methoxy-1-naphthaldehyde-d3-assays\]](https://www.benchchem.com/product/b584897/docs#technical-support-center-7-methoxy-1-naphthaldehyde-d3-assays)

Disclaimer & Data Validity:

The information provided in this document is for Research Use Only (RUO) and is strictly not intended for diagnostic or therapeutic procedures. While BenchChem strives to provide accurate protocols, we make no warranties, express or implied, regarding the fitness of this product for every specific experimental setup.

Technical Support: The protocols provided are for reference purposes. Unsure if this reagent suits your experiment?

Need Industrial/Bulk Grade? [Request Custom Synthesis Quote](#)

BenchChem

Our mission is to be the trusted global source of essential and advanced chemicals, empowering scientists and researchers to drive progress in science and industry.

Contact

Address: 3281 E Guasti Rd

Ontario, CA 91761, United States

Phone: (601) 213-4426

Email: info@benchchem.com

Contact our Ph.D. Support Team for a compatibility check